

**TABLE OF CONTENTS**

**DIVISION 600  
FLEXIBLE PAVEMENT**

<b>SECTION</b>	<b>PAGE</b>
601 – ASPHALT APPLICATION TEMPERATURES .....	1
602 – HOT MIX ASPHALT (HMA) CONSTRUCTION (Quality Control/Quality Assurance (QC/QA)).....	2
603 – ASPHALT PAVEMENT SMOOTHNESS .....	33
604 – COLD RECYCLED ASPHALT CONSTRUCTION (CIR).....	38
605 – SURFACE RECYCLED ASPHALT CONSTRUCTION.....	41
606 – MICROSURFACING.....	44
607 – ASPHALT PRIME COAT .....	47
608 – CHIP SEALS.....	49
609 – SINGLE ASPHALT SURFACE TREATMENT .....	53
610 – DOUBLE ASPHALT SURFACE TREATMENT .....	57
611 – HOT MIX ASPHALT (HMA)-COMMERCIAL GRADE.....	62
612 – MILLING .....	67
613 – ULTRATHIN BONDED ASPHALT SURFACE .....	68
614 – HMA BASE (REFLECTIVE CRACK INTERLAYER (RCI)) .....	80
615 – SAW AND SEAL JOINTS (HMA OVERLAY).....	92



**601 - ASPHALT APPLICATION TEMPERATURES**

**SECTION 601**

**ASPHALT APPLICATION TEMPERATURES**

**601.1 DESCRIPTION**

The application temperatures for the various type and grades of asphalts shall be within the ranges listed in **TABLE 601-1** or as specified on the asphalt producer’s Bill of Lading.

<b>TABLE 601-1: ASPHALT APPLICATION TEMPERATURES</b>				
<b>TYPE AND GRADE</b>	<b>TEMPERATURE RANGE (°F)</b>			
	<b>Spraying</b>		<b>Plant Mixing</b>	
	<b>Min.</b>	<b>Max.</b>	<b>Min.</b>	<b>Max.</b>
Asphalt Binder	275	340	*	*
Asphalt Cement (AC-20-5TR)	325	350	NA	NA
Asphalt Cement (AC-20-XP)	325	350	NA	NA
Asphalt Cement (AC-10-2TR)	300	350	NA	NA
Asphalt Cement (AC-10-XP)	300	350	NA	NA
Cutback Asphalt, MC 30	88	125	88	125
Cutback Asphalt, MC & RC 70 & 250	125	200	125	200
Cutback Asphalt, MC & RC 800 & 3000	150	250	150	250
Asphalt Rejuvenating Agent, ARA-1P	70	150	70	150
Emulsified Asphalt, CRS-1H, RS-1H, SS-1HP, CMS-1, MS-1, HFMS-1, RS-1HP, CRS-1HP	100	180	100	180
Emulsified Asphalt, SS-1H, CSS-1H	None	150	None	150
Emulsified Asphalt, CSS-1HM, CSS-Special	None	120	None	120
EBL	120	180	NA	NA

\* Use the Producer’s recommended mixing temperature range.

All asphalt binders and cutback asphalts reheated to temperatures 50°F more than the maximum in **TABLE 601-1** will be considered overheated and may be rejected pending re-sampling and re-testing of the material at the discretion of the Engineer.

All emulsified asphalts reheated to temperatures above the maximum shown above will be considered overheated and may be rejected pending re-sampling and re-testing of the material at the discretion of the Engineer.

**602 - HOT MIX ASPHALT (HMA) CONSTRUCTION**  
**(Quality Control/Quality Assurance (QC/QA))**

**SECTION 602**

**HOT MIX ASPHALT (HMA) CONSTRUCTION**  
**(Quality Control/Quality Assurance (QC/QA))**

**602.1 DESCRIPTION**

Mix and place 1 or more courses of plant produced HMA mixture on a prepared surface as shown in the Contract Documents. Demonstrate quality control by providing the quality control testing.

**BID ITEMS**

HMA Base (\*)(\*\*)(\*\*\*)  
HMA Surface (\*)(\*\*)(\*\*\*)  
HMA Overlay (\*)(\*\*)(\*\*\*)  
HMA Pavement (#) (##)  
HMA Pavement (#) Shoulder  
Emulsified Asphalt (\*\*\*\*)  
Asphalt Core (Set Price)  
Material for HMA Patching (Set Price)  
Quality Control Testing (HMA)  
\*Mix Designation  
\*\*Grade of Asphalt Binder  
\*\*\*Shoulder  
\*\*\*\*Type and Grade of Emulsified Asphalt  
# Thickness  
##Type of surface course HMA mixture

**UNITS**

Ton  
Ton  
Ton  
Square Yard  
Square Yard  
Ton  
Each  
Ton  
Ton

**602.2 CONTRACTOR QUALITY CONTROL REQUIREMENTS**

**a. General.** Provide qualified personnel and sufficient equipment complying with the requirements listed in Part V to conduct quality control testing that complies with Appendix B, Sampling and Testing Frequency Chart for Asphalt Construction Items for Quality Control/Quality Assurance Projects.

Allow the Engineer access to the Contractor's laboratory to observe testing procedures, calculations, test documentation and plotting of test results.

Calibrate and correlate the testing equipment with prescribed procedures, and conduct tests in compliance with specified testing procedures as listed in Part V.

Maintain a Quality Manual in the field laboratory showing the calibrations performed on all test equipment and when the next calibration is due for that equipment. As a minimum, follow the calibration/verification interval established in Table 2: HMA Materials Test Equipment in Section 5.2.7.1-HMA: Contractor's Quality Control Plan, Part V. See also, Section 5.2.7.3-Example of a Laboratory Quality Manual for HMA, Part V.

Store and retain the most recent 2 lots per mix designation of quality control samples for KDOT. KDOT will retain the most recent 2 lots per mix designation gyratory compacted air voids (Va) verification samples and the remaining material not previously used for testing (back half of sample). Do not retain more than the previous 3 lots per mix designation of quality control or verification samples. When the hot mix plant shuts down for the winter, discard the samples after 7 days.

**b. Quality Control Plan (QCP).** At the pre-construction conference, submit to the Engineer for approval, a QCP as outlined in Section 5.2.7-Contractor's Quality Control Plan, Part V. Follow 5.2.7.1-HMA: Contractor's Quality Control Plan in Part V as a general guideline. The Contractor's laboratory and equipment will be inspected and approved as outlined in Section 5.2.7-Contractor's Quality Control Plan, Part V.

Include a listing of the names and phone numbers of individuals and alternates responsible for quality control administration and inspection. On the Contractor's organizational chart, show the specified lines of authority relating both to mix design and quality control operations during production. Post the organizational chart in the Contractor's test facility.

Provide a quality control organization or private testing firm having personnel certified according to the Policy and Procedures Manual for The Certified Inspection and Testing (CIT) Training Program. The testing for this

**602 - HOT MIX ASPHALT (HMA) CONSTRUCTION**  
**(Quality Control/Quality Assurance (QC/QA))**

type of construction will require personnel certified in Aggregate Field Tester (AGF), Aggregate Lab Technician (AGL), Superpave Field (SF), Profilograph (PO) and Nuclear Moisture Density Gauge Tester (NUC) classifications. Provide a minimum of 1 employee on the project certified in the QC/QA Asphalt Specs (QCA) classification.

Only persons certified in the appropriate classifications covering the specific tests required shall perform such testing. At the beginning of the project, provide the Engineer with the list of certified technicians and alternates, phone numbers and tests/inspection they will be performing. As personnel changes and certifications may expire, continue to provide the Engineer with an accurate list.

Provide an organizational chart showing the specified lines of authority relating to both mix design and quality control operations during production. Identify the company official acting as liaison with KDOT, and the Certified Technician who will direct inspection and testing. Post the chart in the test facility.

**c. Required Duties of Certified Technicians.** Be available on the project site whenever HMA is being produced and being placed on the project site. Perform and utilize quality control tests and other quality control practices to assure that delivered materials and proportioning meet the requirements of the mix designs.

Periodically inspect all equipment utilized in transporting, proportioning, mixing, placing and compacting to assure it is operating properly and that placement and compaction comply with the contract requirements.

**d. Contractor's Testing Facilities.** Describe the testing facility and its accreditation in the QCP.

Locate the testing facility either at the plant site or at the project. Obtain approval of the testing facilities and location from the DME before the commencement of mixture production.

Provide suitable space for the required testing equipment. Also, equip the testing facility with these items for the exclusive use of the testing facility's quality control personnel and the Engineer:

A telephone with a private line for the exclusive use of the testing facility's quality control personnel; and

A copying machine for use by the Contractor's personnel and the Engineer.

Broadband internet connection (for 1 computer). If the Engineer determines that broadband internet service is not available, provide a fax machine, at no additional cost.

An air conditioner capable of maintaining a temperature below 77°F in the main part of the Field Office and Laboratory.

Locate the KDOT field laboratory near the Contractor's testing facility and have it fully functional 2 working days before placement of the pre-production mix.

**e. Documentation.** Include in the QCP procedures, charts and forms to be used to provide the required documentation.

Record all original documentation in a bound field book or other KDOT approved bound record and turn over to KDOT at the end of the project.

At all times, have complete records of all inspections and tests available on site for the Engineer. All records documenting the Contractor's quality control inspections and tests become the property of KDOT upon completion of the work.

Indicate the nature and number of observations made, the number and type of deficiencies found, the quantities approved and rejected, and the corrective action taken in the records. Examples of quality control forms and charts are available in Part V, or Contractors may design their own. Documentation procedures are subject to approval by the Engineer before the start of the work and to compliance checks during the progress of the work.

Maintain control charts on an ongoing basis.

Provide the following test data to the KDOT Project Representative:

- Copies of all test results and control charts on a weekly basis, representing the prior week's production;
- Copies of the quality control summary sheet on a daily basis. Include, as a minimum, mix gradation, binder content, theoretical maximum specific gravity ( $G_{mm}$ ), air voids ( $V_a$ ) at  $N_{des}$ , percent  $G_{mm}$  at  $N_{ini}$  and  $N_{max}$ , voids in mineral aggregate (VMA), voids filled with asphalt (VFA) and dust to effective binder content (D/B) ratio; and
- Copies of all failing test results (based on a moving average of 4 tests, when appropriate). Include all applicable sieves, VMA, VFA, density at  $N_{ini}$  and  $N_{max}$ , and D/B ratio.

**f. Testing Requirements.** In the QCP, identify test methods, procedures and equipment proposed for use. Use standard KDOT test methods and properly calibrated measuring and testing equipment as outlined in Part V.

**602 - HOT MIX ASPHALT (HMA) CONSTRUCTION**  
**(Quality Control/Quality Assurance (QC/QA))**

Detail any alternative sampling method, procedure or inspection equipment proposed to be used. Such alternatives are subject to review and approval by the DME.

Take all samples for tests and perform in-place tests at random locations, selected according to the Contractor's QCP and at the rates specified in the Sampling and Testing Frequency Chart for Hot Mix Asphalt for Quality Control/Quality Assurance Projects in Appendix B, Part V.

**g. Pre-Production Testing Requirements.**

(1) The Engineer will observe the Contractor obtaining and splitting the pre-production test section sample into 3 representative portions. Each sample set shall consist of enough material for 2 gyratory specimens, theoretical  $G_{mm}$  and ignition burnoff.

(2) Mold 2 gyratory specimens from the 1<sup>st</sup> sample set immediately, while still hot. Additional heating may be required to raise the temperature of the sample to compaction temperature. Determine  $G_{mm}$ , perform ignition burnoff and complete calculations.

(3) Provide the KDOT Field Representative with the 2<sup>nd</sup> sample set. The KDOT Field Representative will mold 2 gyratory specimens, determine  $G_{mm}$ , perform ignition burnoff and complete calculations.

(4) Retain or provide the 3<sup>rd</sup> sample set to the KDOT District Materials Representative.

(5) The results of the testing will be compared. If Contractor and KDOT field laboratory test results do not compare favorably, the District Materials Laboratory will test their  $\frac{1}{3}$  of the sample. This sample will be transported to the District Materials Laboratory, after it has cooled to ambient air temperature. KDOT personnel will reheat the sample to compaction temperature, mold 2 gyratory specimens, determine  $G_{mm}$ , perform ignition burnoff and complete calculations. If the 3<sup>rd</sup> sample set is collected, transported while hot to the District Materials Laboratory and compacted in less than 2 hours, then, at the DME's discretion, the requirement to cool the sample may be waived.

If results are not acceptable to either party, repeat the above steps in **subsections 602.2g.(1) through (5)** for the Contractor's Field Laboratory, KDOT's Field Laboratory, and District Materials Laboratory until the issues may be resolved satisfactorily by all parties.

**h. Lot 1 Testing Requirements.**

(1) Sequence of Sampling. KDOT field personnel will determine the random truckload for the Contractor for sublots A, B, C and D, and the KDOT verification test.

The verification sample will be sampled and tested by KDOT field personnel. The verification sample shall be randomly taken within the lot and shall not be the same truckload as selected for the Contractor's subplot A, B, C or D.

KDOT field personnel will:

- provide the random spots to sample from behind the paving operations before compaction (KT-25);
- not supply the Contractor the identity of the truckload to be sampled ahead of time;
- notify the Contractor's laboratory of which truck to sample after the aggregate has left the cold feeds, and before the truck is finished loading; and
- determine whether the split sample will be taken from subplot A or B and notify the Contractor.

(2) Split Samples. The Contractor shall:

- obtain a sample large enough to split 3 ways for testing;
- retain and test  $\frac{1}{3}$  of the sample;
- supply  $\frac{1}{3}$  of the sample to the KDOT field laboratory for testing; and
- supply  $\frac{1}{3}$  of the sample to the KDOT District Materials Laboratory for testing.

(3) Results. At a minimum, compare  $G_{mm}$  and  $V_a$  results. The acceptable differences are 0.019 and 0.5%, respectively. If the results exceed these differences, take an additional split sample in Lot 1 from subplot C or D, as time permits.

If test results do not compare favorably, KDOT and the Contractor will investigate the differences in test results together and take appropriate action. The Contractor's test results will be used for quality control. KDOT Field Laboratory test results and District Materials Laboratory test results will be reported as "information only" samples.

**602 - HOT MIX ASPHALT (HMA) CONSTRUCTION**  
**(Quality Control/Quality Assurance (QC/QA))**

**i. Testing Requirements for Lots 2 and Greater.**

(1) Take all samples for tests at random locations as designated in the approved QCP at the rates specified in Appendix B, Part V.

Provide the Engineer with the random locations before going to the roadway to determine density or sample the HMA. The Engineer reserves the right to generate the random locations. If the Engineer generates the random locations, the Contractor will be notified before going to the roadway to sample the HMA or determine density.

(2) Conduct the tests for mixture properties, aggregate gradation and binder content on representative portions of the HMA, quartered from the larger sample of HMA. Take a random sample weighing a minimum of 55 pounds from behind the paver and transport it to the test facility, using a method to retain heat to facilitate sample quartering procedures.

(3) Record and document all test results and calculations on data sheets provided by KDOT. Record specific test results on a daily summary sheet provided by KDOT to facilitate the computation of moving test averages. Base moving averages on 4 consecutive test results. Calculations are to be based on the precision displayed on the data sheets. Use "precision displayed" when calculating within Excel. Appendix B, Part V shows the accuracy to "record to" for the tests listed. Include a description of quality control actions taken (adjustment of cold feed percentages, changes in Job Mix Formulas (JMF), etc.) in the Daily Quality Control Summary Sheet. In addition, post and keep current quality control charts, showing both individual test results and moving average values. As a minimum, plot the single test values and the 4 test moving average values, as applicable, on KDOT approved control charts for the mix characteristics shown in **TABLE 602-12**.

(4) If the Contractor and Engineer agree, the procedures shown for sampling, testing and evaluation of Lot 1 in **subsection 602.2h**, may be used for any other Lot produced on the project.

**g. Corrective Action.** In the QCP, identify procedures for notifying the Engineer when corrective measures must be implemented, and for halting production.

**h. Non-Conforming Materials.** In the QCP, specifically address how non-conforming materials will be controlled and identified. Establish and maintain an effective and positive system for controlling non-complying material, including procedures for its identification, isolation and disposition. Reclaim or rework non-complying materials according to procedures acceptable to the Engineer. This could include removal and replacement of in-place pavement.

Positively identify all non-conforming materials and products to prevent use, shipment and intermingling with complying materials and products. Provide holding areas, mutually agreeable to the Engineer and Contractor.

### **602.3 MATERIALS**

**a. Asphalt Binder.** Provide Asphalt Binder that complies with **DIVISION 1200**. Post a legible copy of the latest bill of lading for the Asphalt Binder on or near the gyratory compactor. Use the mixing and compaction temperatures shown on the bill of lading; however, the maximum mixing or compaction temperature is 340°F, unless otherwise approved by the Field Materials Engineer. Notify the Engineer if the mixing or compaction temperature changes.

Exception: The mixing temperature may be increased no more than 10°F above the maximum mixing temperature shown on the bill of lading provided all the following are met:

- The air temperature is below 70°F.
- The plant has not produced mix earlier in the day.
- Do not exceed a mix temperature of 350°F.
- No truck has returned for its second load of the day.

Once a previously loaded truck returns for its next load, reduce the temperature to not higher than the maximum mix temperature shown on the bill of lading, not to exceed 340°F.

**b. Reclaimed Asphalt Pavement (RAP) and Recycled Asphalt Shingles (RAS).** Provide RAP and RAS that comply with **SECTION 1103**.

**c. Aggregates.** Provide aggregates that comply with **SECTION 1103**.

**d. Combined Aggregates.** Provide combined aggregates for the mixes required in the Contract Documents as shown in **TABLE 602-1**.

**602 - HOT MIX ASPHALT (HMA) CONSTRUCTION**  
**(Quality Control/Quality Assurance (QC/QA))**

Mixes may use any combination of aggregate and mineral filler supplements complying with the applicable requirements in **TABLES 1103-1** and **1103-2**.

Provide materials with less than 0.5% moisture in the final mixture.

The maximum quantity of crushed steel slag used in the mix is 50% of the total aggregate weight.

For all mixes used on the traveled way, the maximum quantity of natural sand is 35%.

Natural sand shall be called SSG-1, SSG-2, etc. in the mix design.

Additional requirements for SM-9.5T and SR-9.5T:

- Traveled way mixes shall include a minimum of 40% primary aggregate based on total aggregate weight;
- A minimum of 50% of the plus No. 4 mesh sieve material in the mixture shall be from the primary aggregate;
- A minimum of 45% of the plus No. 8 mesh sieve material in the mixture shall be from the primary aggregate; and
- Primary aggregates are designated as CS-1 (excluding limestone), CS-2 (excluding limestone), CG, CH-1 and CSSL as described in **subsection 1103.2a.(1)**. Primary aggregate requirements do not apply to the mixture used on the shoulder.

**e. Contractor Trial Mix Design.** A minimum of 10 working days before the start of HMA production, submit in writing to the DME for review and approval, a proposed JMF for each combination of aggregates. For each JMF submitted, include test data to demonstrate that mixtures complying with each proposed JMF shall have properties specified in **TABLE 602-1** for the designated mix type at the Recommended Percent Asphalt ( $P_{br}$ ). Submit the proposed JMF on forms provided by KDOT. Submit the worksheets used in the design process to include at a minimum the mix properties listed in **TABLE 602-2**. Contact the DME to determine if additional information should be submitted. Provide sufficient material as identified in **TABLE 602-3**. Contact the DME to determine if additional material is needed for additional design checks such as the modified Lottman test (KT-56).

When more than 25% of the mix is comprised of siliceous virgin aggregates and/or RAP, add anti-strip to the mix. The minimum amount of anti-strip required in the mix is 0.01% for every percent of natural sand and RAP in the mix. Thus, if 25% natural sand and 10% RAP is in a mix, then 0.35% anti-strip by weight of virgin asphalt binder is required in the mix.

If during production, the Tensile Strength Ratio (TSR) values (both KDOT and Contractor) exceed 85%, then the Contractor and the DME, working together, may decide on a lower amount of anti-strip.

Submit for the Engineer's review and approval, the test data listed in **TABLE 602-4** for each blend and the proposed JMF. In addition, for mixes containing RAP or RAS, submit for the Engineer's review and approval, the test data listed in **TABLE 602-5** for each blend and the proposed JMF. Submit a mix design for each blend and the proposed JMF as outlined in **TABLE 602-6**.

For each aggregate used in the mix design, determine the specific gravity using KT-6. This may be accomplished while the project is being constructed or anytime during the 12 months preceding the start of construction on a project. If construction has not yet begun, notify the DME 5 working days prior to obtaining the material for the specific gravity test so that companion samples may be obtained at the same time. If construction has already begun on the project, then determine the specific gravity values of the individual aggregates before 10,000 tons of HMA is produced. Provide the test results to the DME within 14 days of sampling the material. If the producer of the aggregate has been required to submit material to KDOT for a new Official Quality test, since the time the Contractor ran the specific gravity tests, then perform KT-6 on the aggregate currently produced. Do not use the specific gravity values obtained from these tests in the mix design calculations for current projects, unless mutually agreeable to both parties. Use the information, as soon as it becomes available, as part of the process to verify and update the "Monthly Hot Mix Aggregate Specific Gravity Values" posted on KDOT's Internet site.



**602 - HOT MIX ASPHALT (HMA) CONSTRUCTION**  
**(Quality Control/Quality Assurance (QC/QA))**

<b>TABLE 602-1: COMBINED AGGREGATE REQUIREMENTS</b>											
Nom. Max. Size Mix Designation	Percent Retained – Square Mesh Sieves									Min. VMA (%)	D/B Ratio
	1 1/2"	1"	3/4"	1/2"	3/8"	No. 4	No. 8	No. 16	No. 200		
SM-4.75A SR-4.75A			0	0-2	0-5	0-10		40-70	88.0-94.0	16.0	0.9 – 2.0
SM-9.5A SR-9.5A			0	0-2	0-10	10 min.	33-53		90.0-98.0	15.0	0.6 – 1.2
SM-9.5B SR-9.5B			0	0-2	0-10	10 min.	53-68		90.0-98.0	15.0	0.8 – 1.6
SM-9.5T SR-9.5T			0	0-2	0-10	10 min.	53-68		90.0-98.0	15.0	0.8 – 1.6
SM-12.5A SR-12.5A		0	0-2	0-10	10 min.		42-61		90.0-98.0	14.0	0.6 – 1.2
SM-12.5B SR-12.5B		0	0-2	0-10	10 min.		61-72		90.0-98.0	14.0	0.8 – 1.6
SM-19A SR-19A	0	0	0-10	10 min.			51-65		92.0-98.0	13.0	0.6 – 1.2
SM-19B SR-19B	0	0	0-10	10 min.			65-77		92.0-98.0	13.0	0.8 – 1.6

1. The requirements for Coarse Aggregate Angularity (CAA); Fine Aggregate Angularity (FAA); Sand Equivalent (SE); Gyrotory compaction revolutions  $N_{ini}$ ,  $N_{des}$ ,  $N_{max}$ ,  $N_{ini}$  level of compaction and VFA shall be as shown in the Contract Special Provisions for each mix designation.
2. The flat and elongated particles in the combined coarse aggregate shall not exceed 10% for the total sample.
3. The maximum percent moisture in the final mixture shall not exceed 0.5 for any mix designation.
4. The target air voids ( $V_a$ ) for any mix designation shall be 4.0% at  $N_{des}$  gyrations.
5. The minimum tensile strength ratio (%TSR) shall be 80% for any mix designation.
6. The level of compaction of the mix when compacted to  $N_{ini}$  gyrations shall be less than the percent of the  $G_{mm}$  shown in the Contract Special Provision, and when compacted to  $N_{max}$  gyrations shall be a maximum of 98.0% of the  $G_{mm}$ .

<b>TABLE 602-2: MIX PROPERTIES</b>			
Property	Abbreviation	Test Method	Additional Information
Air Voids	$V_a$	KT-15 & KT-58	Calculated from $G_{mm}$ and $G_{mb}$ . Run at the $P_{br}$ .
Recommended Percent Asphalt	$P_{br}$		Produce a mix with a $V_a$ of 3.5% to 4.5%.
Theoretical Maximum Specific Gravity	$G_{mm}$	KT-39	Rice Test.
Percent Tensile Strength Ratio	%TSR	KT-56	Run test at $P_{br}$ or at 0.3% to 0.5% less than $P_{br}$
Sand Equivalent	SE	KT-55	
Bulk Specific Gravity of HMA	$G_{mb}$	KT-15	Compacted Mix Property.
Percent $G_{mm}$ at $N_{ini}$ and $N_{des}$ and $N_{max}$	$\%G_{mm} @ N_{ini}$ $\%G_{mm} @ N_{des}$ $\%G_{mm} @ N_{max}$	KT-15	Use $G_{mm}$ value from KT-39. Calculated from Gyrotory Compaction height data, $G_{mm}$ , and $G_{mb}$ .
Voids in Mineral Aggregate	VMA	KT-15 & KT-6	Calculated from $G_{mb}$ , $G_{sb}$ , $P_b$ .
Voids Filled with Asphalt	VFA		Calculated from VMA and $V_a @ N_{des}$ .
Coarse Aggregate Angularity	CAA	KT-31	
Fine Aggregate Angularity	FAA	KT-50	

Formulas for calculations are in the Superpave Volumetric Mixture Design and Analysis Handbook.

**602 - HOT MIX ASPHALT (HMA) CONSTRUCTION**  
**(Quality Control/Quality Assurance (QC/QA))**

<b>TABLE 602-3: MATERIAL SUBMITTALS</b>			
<b>Submittal</b>	<b>Quantity</b>	<b>Description</b>	<b>Additional Information</b>
Aggregate for KT-15	3 Samples	Sized for 6 inch Plugs	Comply with Job Mix Gradation.
Aggregate for KT-39	2 Samples	Sized for $G_{mm}$ Testing	Comply with Job Mix Gradation.
Binder for KT-15	As Needed	Sized for 3 Plugs at $P_{br}$	
Binder for KT-39	As Needed	Sized for 2 $G_{mm}$ Tests	
Each Aggregate for KT-6	As Needed	Specific Gravity Test	
Uncompacted HMA Sample	35 lbs	Cool sample to room temperature	If transported hot and compacted within 2 hours, then requirement to cool sample may be waived by the DME.
Gyratory Plugs at $N_{max}$	2 Plugs	Compacted at $P_{br}$	Compacted to $N_{max}$ .

<b>TABLE 602-4: TEST DATA SUBMITTALS</b>	
<b>Submittal</b>	<b>Information</b>
Asphalt Binder	Source, Grade, Specific Gravity, Mixing and Compaction Temperature from the Producer of the asphalt binder.
Each Aggregate	Source and Producer, including Legal Description.
Gradation of Each Aggregate	Percentage Retained to nearest 1% (except nearest 0.1% for No. 200 sieve) Derive RAP gradation after residual binder is removed. Derive RAS gradation after residual binder is removed or from the Shingle Aggregate Gradation table in <b>SECTION 1103</b> .
Material Proportioning	Proportion of each material is shown in percentage of aggregate.
Composite Gradation	Based on Gradation of Each Aggregate and Material Proportioning.
Composite Gradation Plot	Plotted on KDOT Form 712 (0.45 power graph paper).
Asphalt Binder Added	Percentage to nearest 0.01% based on total weight of the mixture.
Aggregate	Percentage of flat and elongated particles in the coarse aggregate, CAA and FAA.
%TSR	Percent Tensile Strength Ratio of the Mixture (Modified Lottman Test).
Sand Equivalent	SE for the combined virgin aggregates.

<b>TABLE 602-5: RAP AND RAS TEST DATA SUBMITTALS</b>	
<b>Submittal</b>	<b>Information</b>
RAP and RAS	Source and location where RAP will be obtained. Source and location where RAS will be obtained.
RAP Aggregate	Bulk Specific Gravity ( $G_{sb}$ ). Use the $G_{sb}$ provided on the Contract Special Provision. If no value is provided, the Effective Specific Gravity ( $G_{se}$ ) shall be calculated as shown in subsection 5.10.4, Part V and used as the $G_{sb}$ .
RAS Aggregate	Bulk Specific Gravity ( $G_{sb}$ ). The Effective Specific Gravity ( $G_{se}$ ) shall be calculated as shown in subsection 5.10.4, Part V and used as the $G_{sb}$ .
Asphalt Binder Content of RAP Asphalt Binder Content of RAS	Determined from ignition oven analysis using KT-57.
RAP $G_{mm}$ RAS $G_{mm}$	Determined by KT-39.
Asphalt Binder Specific Gravity	Specific Gravity of the asphalt binder in the RAP and RAS ( $G_b$ ) shall be set equal to 1.035.
Corrected Asphalt Binder Content of the total recycled mixture	Determined from ignition oven analysis using KT-57.

**602 - HOT MIX ASPHALT (HMA) CONSTRUCTION  
(Quality Control/Quality Assurance (QC/QA))**

<b>TABLE 602-6: MIX DESIGN TEST DATA SUBMITTALS</b>	
<b>Submittal</b>	<b>Information</b>
Minimum of 2 Mix Designs	As a minimum, 1 mix design at the $P_{br}$ and 1 mix design at 0.3% to 0.5% below the $P_{br}$
$G_{mm}$	Determined at each binder content.
Individual and Bulk Specific Gravity Tests	Provide results for a minimum of 2 specimens at each binder content.
Percent Air Voids	Provide % $V_a$ in the mixture for each binder content when compacted to $N_{ini}$ , $N_{des}$ and $N_{max}$ gyratory revolutions along with copies of the Gyratory graphs.
Percent VMA	Provide %VMA at each binder content. (Note: The Contractor is cautioned that plant produced material generally yields a mixture with less VMA than predicted by the design. In such case, the design VMA should be increased above the specified minimum accordingly.)
D/B Ratio	Calculate to the nearest 0.1% at each binder content.

**f. Additives.** Provide Warm Mix Asphalt (WMA) additives or processes that comply with **SECTION 1203**. The Contractor is permitted to use WMA, unless otherwise shown in the Contract Documents.

For mixes containing Warm Mix Asphalt (WMA) additives, submit for the Engineer's review and approval, the additive or process used, the recommended rate of application, and the temperature ranges for mixing and compaction.

Mixing temperature range is provided by the Asphalt Binder Supplier. When using WMA, the mixing temperature may be reduced no more than 30°F for WMA water foaming processes, and no more than 70°F for WMA chemical and organic additives. The minimum mixing temperature for WMA is 220°F.

**602.4 CONSTRUCTION REQUIREMENTS**

**a. Plant Operation.** Adjust all plant operations to operate continuously.

(1) Preparation of the Asphalt Binder. Heat the asphalt binder to within a range as specified in **SECTION 601**. When heating the asphalt binder to the specified temperature, avoid local overheating. At all times, provide a continuous supply of the asphalt binder to the mixer at a uniform temperature. Asphalt binder received from the refinery at temperatures less than 375°F may be used as received, if the requirements regarding the reheating of asphalt binder in **SECTION 601** are met.

(a) Commingling of Asphalt Binders. Do not add or commingle asphalt binders from 2 or more sources into a storage tank. If this occurs, the contents of the storage tank are considered contaminated. Do not use the contents of the storage tank on the project, except as follows: It is permissible, at the Contractor's option, to thoroughly mix the contents of the tank and request sampling of the mixture. Submit the sample to the MRC for testing. Do not use the asphalt binder until approved, and when needed, a new mix design evaluation is completed.

(b) Asphalt Binder Sources. Before changing asphalt binder sources on a project, obtain approval from the DME. A new JMF may be required.

(c) Anti-Strip Additives. If liquid anti-strip additives are added at the Contractor's plant, install a "totalizer" to monitor the quantity of anti-strip additive being added. The Engineer may approve alternative methods for including anti-strip additives in a batch plant. If added at the plant, the anti-strip will be added in line with the asphalt binder as it is being transferred from the transit unit to the asphalt binder storage tank. Provide a method for the Engineer to monitor the percent of additive being added.

If hydrated lime is added, mix it in an approved pug mill to coat the combined aggregates. Moisten the combined virgin aggregate to a minimum of 3% above the saturated surface dry condition prior to, or during the addition of the hydrated lime.

(d) WMA Additives. If WMA additives are added at the Contractor's plant, install a "totalizer" to monitor the quantity of WMA additive being added. The Engineer may approve alternative methods for including chemical and organic WMA additives in a batch plant. If added at the plant, chemical and organic WMA additives will be added in line with the asphalt binder as it is being transferred from the transit unit to the asphalt binder storage tank. Provide a method for the Engineer to monitor the percent of additive being added.

**602 - HOT MIX ASPHALT (HMA) CONSTRUCTION**  
**(Quality Control/Quality Assurance (QC/QA))**

(2) Preparation of Mineral Aggregate. When the mineral aggregate is composed of 2 or more ingredients, combine as shown in the approved JMF.

(a) Temperature Requirements. Dry the aggregate for the mixture and heat to a temperature to obtain an asphalt-aggregate mixture temperature immediately after mixing within the 75 to 150 second Saybolt viscosity range of the asphalt binder used. Obtain the temperature for this viscosity range from the MRC or the Asphalt Binder Producer. No mixing or compaction temperatures are to exceed 340°F without approval from the Field Materials Engineer. The minimum temperature may be revised by the DME provided it is demonstrated that satisfactory results may be obtained at a lower temperature. In such event, deliver the HMA to the paver at a temperature sufficient to allow the material to be satisfactorily placed and compacted to the specified density and surface tolerance requirements.

(3) Preparation of HMA. Introduce asphalt binder into the prepared aggregate in the proportionate amount determined by the  $P_{br}$  in the JMF.

(a) Basis of Rejection. HMA will be rejected if the aggregate, as it is discharged from the drum or the pugmill, contains sufficient moisture to cause foaming of the mixture, or if the temperature of the aggregate is such that the asphalt-aggregate mixture temperature is outside the range specified in **SECTION 601**.

(b) Mixing Time. Operate drum mixers at a rate to provide uniform aggregate coating in a continuous operation. For batch and continuous type plants, the minimum wet mixing time is 40 seconds. In all cases, mix a sufficient time to produce a uniform mixture in which all the aggregate particles are thoroughly coated. On batch plants, begin the timing at the start of the asphalt binder introduction into the pugmill, and end upon the opening of the discharge gate. For continuous flow plants, mixing time in seconds shall equal:

[pugmill dead capacity in pounds] divided by [pugmill output in pounds per second].

(c) Manufacturer's Specifications. Operate all drying, pumping and mixing equipment within the limits specified by the manufacturer, unless it can be demonstrated to the satisfaction of the Engineer that such limits may be exceeded without detriment to the HMA.

(d) Batcher Operation. Coordinate HMA batchers (Gob Hoppers) with the plant production rate at all times so the hopper is more than  $\frac{3}{4}$  full before the gates open, and the gates close before material can drop through the gob hopper directly into the surge bin, weigh hopper or truck.

(e) Wasted Material. Wasted material is not measured for pay.

If after an interruption of production, the drum-mixer contains cold, uncoated or otherwise unsuitable material, waste material through a diversion chute. In a continuous or batch plant drier, waste unsuitable material through the pugmill.

At the end of a production run, waste any segregated material in the cone of the storage bin.

(4) End of Day Quantities. At the end of each day of production provide the Engineer with a document signed by the Plant Foreman or the Project Manager listing the dry weight of each aggregate, mineral filler, RAP, and WMA chemical or organic additive; the tons of asphalt binder, the tons of anti-strip agent used for the project during the day, and the tons of water used in the WMA foaming process. The dry weight is the tons of the material less the water content.

**b. Road Surface Preparation.**

(1) Preparation of Earth Subgrade. When the HMA is placed on a prepared subgrade, and unless other subgrade preparation is called for in the Contract Documents, perform the following:

At all grade control points, such as existing pavements and bridges, excavate the subgrade according to the specified grades and lines, prior to any subgrade treatment. Prior to the delivery of materials for the base course, prepare the subgrade surface by sprinkling with water, lightly scarifying where necessary, and blading and rolling, until the proper crown is obtained. Disturb the originally compacted crust or top portion of the subgrade as little as possible.

Maintain the subgrade as prepared until it is covered with the base course. Repair any defects which may develop, at the Contractor's expense, to the satisfaction of the Engineer.

(2) Trimming of Subgrade (Untreated, Treated or Modified), Aggregate Base or Granular Sub-base for HMA Pavement. Before placing the subsequent layer of the pavement structure, trim the subgrade (untreated, treated or modified), aggregate base or granular subbase. Use an automated, electronically controlled machine that trims with a rotary cross-shaft trimmer to establish and control the line, grade and typical cross-section as shown in the Contract Documents. The Engineer may waive the use of automatically controlled equipment on areas of narrow width or

**602 - HOT MIX ASPHALT (HMA) CONSTRUCTION**  
**(Quality Control/Quality Assurance (QC/QA))**

irregular dimensions. Operate all trimming equipment far enough in advance of the paving operation to allow ample opportunity to check the grade and make any needed corrections.

Prior to paving, construct ditches and drains to drain the highway effectively. Maintain the finished subgrade in a smooth and compacted condition to readily drain.

Do not place pavement upon a frozen or muddy subgrade.

(3) Preparation of an Existing Asphalt Pavement. Clean the surface to remove all foreign material and broom to remove dust. Excavate areas shown in the Contract Documents to be patched to a depth directed by the Engineer. Fill with HMA and compact.

(4) Preparation of an Existing Concrete or Brick Pavement. Clean all foreign material and broom to remove dust. Clean and fill cracks and joints, and construct surface leveling as shown in the Contract Documents.

(5) Tack Coat. Prior to placing the HMA, apply a tack coat to the existing surface, as shown in the Contract Documents. When warranted by weather conditions, the Engineer may authorize a change in the asphalt for tack coat. When such changes are made, the price per ton of material being used will be the unit price bid for the material designated in the contract plus or minus the difference in the invoice price per ton of the 2 materials at the refinery as determined at the time of application.

**c. Weighing Operations.** See **SECTION 109** for details regarding weighing operations.

**d. Hauling Operations.** Schedule operations to minimize hauling over a surface course.

Deliver HMA to the paver at a temperature sufficient to allow the material to be placed and compacted to the specified density and surface tolerance.

**e. Paving Operations.** Except when placing SM-4.75A, SM-9.5A or SR-9.5A asphalt mixtures, remix the material transferred from the hauling unit, prior to placement. Use equipment such as a mobile conveyor, material transfer device, shuttle buggy material transfer vehicle, material transfer paver or paver with remixer conveyor system. After starting the project with the equipment listed above, and after producing HMA pavement density within the limits specified in **TABLE 602-7**, the Engineer will consider other types of equipment or modifications to pavers that will produce less segregation. The use of equipment as noted above shall not relieve the Contractor of the responsibility to comply with **TABLE 602-7**. The Engineer will check the pavement for longitudinal streaks and other irregularities. Make every effort to prevent or correct any irregularities in the pavement, such as changing pavers or using different and additional equipment.

Do not raise (dump) the wings of the paver receiving hopper at any time during the paving operation. The Engineer may waive this requirement if it is determined that raising (dumping) the wings will not produce detrimental segregation. If segregation or irregularities in the pavement surface or density are noted, review the plant, hauling and paving operations and take corrective action. The recommendations made in KDOT's "Segregation Check Points" should reduce the segregation and irregularities to an acceptable level. Copies of KDOT's "Segregation Check Points" may be obtained from the KDOT District Office or Field Engineer.

Spread the HMA and finish to the specified crown and grade using an automatically controlled HMA paver. Operate the paver at a speed to provide a uniform rate of placement without undue interruption. At all times, keep the paver hopper sufficiently full to prevent non-uniform flow of the HMA to the augers and screed.

If the automatic grade control devices break down, the Engineer may allow the paver to operate to the close of the working day, provided the surface is satisfactory. Do not operate the paver without working automatic control devices upon another lift that was laid without automatic controls.

(1) Surface Quality. Spread the HMA without tearing the surface. Strike a finish that is smooth, free of segregation, true to cross section, uniform in density and texture and free from surface irregularities. If the pavement does not comply with all of these requirements, plant production and paving will be suspended until the deficiency is corrected.

The Engineer will check segregation and uniformity of density using methods outlined in Section 5.8.3 - Segregation Check Using the Nuclear Density Gauge, Part V. For shoulders with a plan width of less than or equal to 3 feet, and placed at the same time as the traveled way, do not take nuclear density readings on the shoulder nor within 1 foot of the shoulder unless the pavement section is uniform across the entire roadway. The acceptable criteria for density uniformity are in **TABLE 602-7**.

**602 - HOT MIX ASPHALT (HMA) CONSTRUCTION  
(Quality Control/Quality Assurance (QC/QA))**

<b>TABLE 602-7: SEGREGATION AND UNIFORMITY OF DENSITY CHECK</b>		
<b>Mix Designation</b>	<b>Maximum Density Range (highest minus lowest)</b>	<b>Maximum Density Drop (average minus lowest)</b>
All	4.4 lbs./cu. ft.	2.2 lbs./cu. ft.

Whenever the results from 2 consecutive density profiles fail to comply with both of the requirements listed in **TABLE 602-7**, plant production and paving will be suspended. Follow the procedures listed in the Profile Evaluation Subsection of Section 5.8.3-Segregation Check Using the Nuclear Density Gauge, Part V until production may be resumed.

Joint density testing and the associated requirements listed below do not apply for HMA lift thicknesses less than or equal to 1 inch.

Evaluate the longitudinal joint density using methods outlined in Section 5.8.4-Joint Density Evaluation Using the Nuclear Density Gauge, Part V. Although it is the Contractor's responsibility to perform the joint density evaluation, the Engineer may make as many independent joint density verifications as deemed necessary at the random sample locations. The Engineer's results will be used for acceptance for joint density, whenever available. The acceptable criteria for joint density are in **TABLE 602-8**.

<b>TABLE 602-8: JOINT DENSITY REQUIREMENTS</b>	
<b>Nuclear Gauge Readings</b>	<b>Requirement</b>
Interior Density minus Joint Density	≤ 3.0 lbs./cu. ft.
OR	
Joint Density	≥ 90.00% of G <sub>mm</sub>

If the results of 2 consecutive density profiles fail to comply with **TABLE 602-8**, the plant production and paving operations will be suspended. Follow the procedures listed in the Joint Evaluation Subsection of Section 5.8.4-Joint Density Evaluation Using the Nuclear Density Gauge, Part V, until production may be resumed.

(2) Leveling Courses. In general, spread leveling course mixtures by the method to produce the best results under prevailing conditions to secure a smooth base of uniform grade and cross section. The leveling course may be spread with a properly equipped paver or motor grader.

(3) Lift Thickness. Except for leveling courses or when shown otherwise in the Contract Documents, **TABLE 602-9** applies. The Engineer may adjust lift thickness to utilize the most efficient method of acquiring specified density and surface quality. The minimum lift thickness for any HMA mixture is 3 times the nominal maximum aggregate size, unless otherwise designated in the Contract Documents or approved by the Engineer.

<b>TABLE 602-9: NOMINAL COMPACTED THICKNESS</b>	
<b>Lift</b>	<b>Maximum Nominal Compacted Thickness</b>
Surface	2 inches
Base	4 inches

(4) Grade Control. Achieve grade control by use of 1 or more of the following grade reference devices. Approval of any of these devices will be based upon satisfactory performance.

(a) Traveling Stringline. Attach a traveling stringline or ski type attachment, a minimum length of 30 feet, to the paver and operate parallel with its line of travel.

(b) Reference Shoe. Attach a short reference shoe or joint matching device to the paver for control in matching surface grades along longitudinal joints.

(c) Erect Stringline. Use an erected stringline consisting of a tightly stretched wire or string offset from and parallel to the pavement edge on 1 or both sides. Erect the stringline parallel to the established pavement surface grade and support at intervals as necessary to maintain the established grade and alignment.

(d) Stringless Paving. Control line, grade and pavement cross-section as shown in the Contract Documents. Use electronic guidance systems that meet the requirements and tolerances listed in **SECTION 802**. Horizontal control is guided by GPS. Vertical control is guided by Total Stations. GPS will not be allowed for Vertical control.

**602 - HOT MIX ASPHALT (HMA) CONSTRUCTION**  
**(Quality Control/Quality Assurance (QC/QA))**

When paving on a fresh subgrade that has not been trimmed by an automatically controlled machine, use an erected stringline or stringless paving to establish grade. Use either of these options on the first or second lift. When directed by the Engineer, use an erected stringline or stringless paving to match grade control points such as bridges.

(5) Compaction of Mixtures. Uniformly compact the HMA as soon after spreading and strike-off as possible without shoving or tearing. Use self-propelled rollers operated at speeds slow enough to avoid displacement of the HMA. Equipment and rolling procedures which result in excessive crushing of the aggregate are prohibited. Use a sufficient number and weight of rollers to compact the HMA to the required density, using a minimum of 2 rollers. See **subsections 602.4e.(6)** for exceptions to the minimum number of rollers. Perform final rolling with a steel roller unless otherwise specified. On the final pass, operate finishing, vibratory rollers in the static mode.

Coordinate the frequency, amplitude and forward speed of the vibratory roller to achieve satisfactory compaction without objectionable undulations. For HMA lifts with a compacted thickness less than 1/4 inch, operate vibratory rollers in the static mode.

Keep rollers in operation as necessary so all parts of the pavement receive substantially equal compaction at the proper time. The Engineer will suspend HMA delivery to the project at any time proper compaction is not being performed.

Remove, replace with suitable material and finish according to these specifications any mixture that becomes loose, broken, mixed with foreign material or which does not comply in all respects with the specifications.

(6) Density Requirements.

(a) For mixes with a specified thickness greater than or equal to 1 1/2 inches:

For lots 1 and 2, control density as shown in **subsection 602.4e.(6)(b)**. Before beginning production, the Contractor has the option to accept the pay adjustment for density on both Lots 1 and 2, or only Lot 2. If the Contractor chooses to accept the pay adjustments for density on both Lots 1 and 2, or only Lot 2, control the density as shown in **subsections 602.4e.(6)(a)(i-ii)**. If the Contractor chooses to accept pay adjustment for density on Lot 1, the pay adjustment can not be rejected on Lot 2.

(i) HMA Overlay. For lots 3 and greater, the lot density requirements and appropriate density pay adjustment factors are shown in **subsection 602.9b**, as the percent of the  $G_{mm}$  value based on the average of the density tests. The standard lot size is 10 density tests. Smaller lot sizes may result as outlined in **TABLE 602-10**. Normally, the  $G_{mm}$  value used to calculate the density percentage is the average value of all  $G_{mm}$  tests conducted the same day the lot was placed and compacted. If less than 3  $G_{mm}$  values were obtained that day, use the moving average value (last 4 tests prior to the end of the day). When starting a mix and less than 4  $G_{mm}$  values have been determined, use the average value of those available at the end of each day.

(ii) HMA Surface, HMA Base and HMA Pavement. For lots 3 and greater, the lower specification limit (LSL) value for density is given in **subsection 602.9c**, along with the appropriate density pay adjustment factor equations. The LSL value is given as a percentage of  $G_{mm}$ . Lot density is determined using the measured density values for all sublots in a lot. The standard lot size is 10 density tests. Smaller lot sizes may result as outlined in **TABLE 602-10**. Normally, the  $G_{mm}$  value used to calculate the density percentage is the average value of all  $G_{mm}$  tests conducted the same day the lot was placed and compacted. If less than 3  $G_{mm}$  values were obtained that day, use the moving average value (last 4 tests prior to the end of the day). When starting a mix and less than 4  $G_{mm}$  values have been determined, use the average value of those available at the end of each day.

(b) For mixes with a specified thickness less than 1 1/2 inches:

These mixes will not have a density pay adjustment. Control density using an approved rolling procedure with random nuclear gauge density determinations. Include a method for controlling density in the QCP.

Designate a "Compaction Foreman". This person shall control compaction procedures, review nuclear gauge results as they are obtained, adjust compaction procedures as needed to optimize compaction and report any changes in the compaction process and results of nuclear gauge testing to the Engineer. The compaction foreman may also be the nuclear gauge operator. The nuclear gauge operator shall continuously monitor compaction procedures. As a minimum, take 10 random nuclear gauge density determinations per day and report results to the Engineer. Throughout the day, nuclear gauge results shall be available for review by the Engineer. The

**602 - HOT MIX ASPHALT (HMA) CONSTRUCTION  
(Quality Control/Quality Assurance (QC/QA))**

compaction foreman shall document at a minimum of once every 2 hours that the approved rolling sequence is being followed. Documentation includes roller passes, the mat temperature at each pass, amplitude setting of rollers and roller speed. Provide the documentation to the Engineer.

Determine and periodically update an approved rolling procedure and periodically, as outlined in this section. As a minimum, evaluate the initial rolling procedure using 3 rollers. If the hot mix plant is operating at over 275 tons per hour, use a minimum of 4 rollers in the initial evaluation. Operate vibratory rollers according to **SECTION 151**. Evaluate HMA paver screed operation with the nuclear gauge at various vibration settings. For screed evaluation, take the nuclear gauge readings directly behind the screed and before rolling. The Compaction Foreman and Engineer will evaluate the densities obtained with the various roller combinations and screed settings to determine the initial approved rolling procedure.

Together, the Compaction Foreman and Engineer will determine when new rolling procedures are required. HMA production may be stopped by the Compaction Foreman or Engineer whenever rolling is not being performed according to the approved rolling procedure.

(c) For all lots, achieve the maximum density before the temperature of the HMA falls below 175°F. When using WMA, achieve the maximum density before the temperature of the WMA falls below 165°F. Do not crush the aggregate. When the mat temperature falls below 175°F or 165°F for WMA, roller marks may be removed from the mat with a self-propelled static steel roller.

<b>TABLE 602-10: DAILY PRODUCTION VS NUMBER OF SUBLOTS AND TEST REQUIREMENTS</b>			
<b>Daily Production (tons)</b>	<b>Number of SUBLots</b>	<b>No. of Cores or Nuclear Density Tests **</b>	<b>No. of Verification Cores or Nuclear Density Tests **</b>
0-599	3*	6*	3*
600-999	4*	8*	4*
1000 or more	5	10	5

\*Minimum number for mixes with a specified thickness of 1½ inches or greater: The Contractor may choose to obtain the number required for 1000 or more tons. If the Contractor chooses to test 5 sublots (10 tests), KDOT will obtain 5 verification tests.

\*\*For mixes with a specified thickness less than 1½ inch: Verification testing may be performed, but is not required. Additional testing may be performed by the Contractor. A minimum of 10 tests are required.

(7) Contact Surfaces. Coat contact surfaces of curbing, gutters, manholes and similar structures with a thin uniform coating of asphalt material. Place the HMA uniformly high near the contact surfaces so that after compaction it shall be approximately ¼ inch above the edge of such structures.

(8) Adjustment of Manholes (Set Price). When required, this work will be performed and paid for under **SECTION 816**.

(9) Construction Joints.

(a) Transverse Construction Joints. Use a method of making transverse construction joints to provide a thorough and continuous bond, provide an acceptable surface texture and meet density requirements. Do not vary the surface elevation more than 3/16 inch in 10 feet, when tested longitudinally across the joint. When required, repair the joints or paving operations will be suspended.

(b) Longitudinal Joints. Construct well bonded and sealed longitudinal joints to obtain maximum compaction at the joint. If deemed necessary by the Engineer to properly seal the joint, apply a light coat of asphalt emulsion or asphalt binder to the exposed edge before the joint is made.

Before placing the fresh HMA against a cut joint or against old pavement, spray or paint the contact surface with a thin uniform coat of asphalt emulsion or asphalt binder. Where a finishing machine is used, make the longitudinal joint by depositing a sufficient amount of HMA to form a smooth and tight joint.

Offset the longitudinal joint in successive courses by 6 to 12 inches. Comply with traffic lane edges for the width of the surface of top course placement.

(10) Shoulder Surfacing and Widening. When the placement width of shoulders or uniform width widenings is less than can be accomplished with a regular paver, spread each course with a mechanical spreading device.

(11) Rumble Strips. When designated, construct rumble strips according to the Contract Documents.

**f. Maintenance of Traffic.** Maintain traffic according to **DIVISION 800** and the following:



**602 - HOT MIX ASPHALT (HMA) CONSTRUCTION  
(Quality Control/Quality Assurance (QC/QA))**

Maintain one-way traffic, and restrict traffic speeds to 20 miles per hour in the vicinity of workers, unless otherwise designated. Use pilot cars to lead traffic through the area of paving and rolling operations, and if directed, through a curing area. The use of flaggers is allowed through patching operations, unless the patching area or distance between flaggers exceeds ½ mile, in which case the use of a pilot car shall be required. On overlay projects with 2 lanes or more in each direction for traffic use, the Engineer may waive the pilot car requirements.

Station one flagger ahead of the application of the tack coat and one flagger ahead of the area being protected from traffic. Take adequate protection for traffic on side roads approaching the tack area.

**g. Treatment of Adjacent Areas.** Pave sideroads, entrances and turnouts for mailboxes as shown in the Contract Documents. Overlay all widening areas designated in the Contract Documents or ordered by the Engineer.

**h. Pavement Smoothness.** Evaluate pavement smoothness according to **SECTION 603** and the following:

<b>TABLE 602-11: MAXIMUM VARIATION OF THE SURFACE</b>	
<b>Length (feet)</b>	<b>Maximum Variation of the Surface (inches)</b>
10	3/16
25	5/16

Correct all humps or depressions exceeding the specified tolerance by removing the defective work and overlaying with new material, or by other means approved by the Engineer. All necessary corrections are at the Contractor’s expense.

**602.5 PROCESS CONTROL**

**a. General.** Establish gradation limits and proportions for each individual aggregate, mineral filler and RAP and RAS, when applicable. Specify the limits and proportions such that the material produced complies with the applicable requirements of the designated mix type. The Contractor is responsible for all process control operations including testing. At no time will KDOT’s representative issue instructions to the Contractor or producer as to setting of dials, gauges, scales and meters. KDOT will collect and test verification samples and assurance samples and inspect the Contractor’s quality control operations.

**b. JMF Adjustments.** Produce a mixture of uniform composition closely complying with approved design JMF to obtain the specified properties when compacted. If, during production, results from quality control tests demonstrate a need to make adjustments to the mix design, then make adjustments to the design JMF single point gradation and binder content to achieve the specified properties. The JMF adjustments shall produce a mix that complies with **TABLE 602-1** for the specified mix designation. When necessary, adjust on a subplot basis. Report the new JMF to KDOT’s field representative and the DME before making such changes, and submit a new mix design for review and approval if required by the DME.

**c. Specification Working Ranges.** Establish acceptable limits for field test results by applying the tolerances shown in **TABLE 602-12** to the JMF or adjusted JMF for binder content. Establish acceptable limits for the other listed mix characteristics by applying the tolerances shown in **TABLE 602-12** to the requirements of **TABLE 602-1**.

**602 - HOT MIX ASPHALT (HMA) CONSTRUCTION  
(Quality Control/Quality Assurance (QC/QA))**

<b>TABLE 602-12: SPECIFICATION WORKING RANGES (QC/QA)</b>				
<b>Mix Characteristic</b>	<b>Tolerance from JMF</b>			
	<b>Single Test Value</b>	<b>Plot</b>	<b>4 Point Moving Average Value</b>	<b>Plot</b>
Binder Content	±0.6%	*	±0.3%	*
<b>Mix Characteristic</b>	<b>Tolerance for Specification Limits</b>			
	<b>Single Test Value</b>	<b>Plot</b>	<b>4 Point Moving Average Value</b>	<b>Plot</b>
Gradation (applicable sieves in TABLE 602-1)	N/A	*	zero tolerance	*
Air Voids @ N <sub>des</sub> gyrations	±2.0%	*	N/A	
Voids in Mineral Aggregate (VMA)	1.0% below min.	*	zero tolerance	*
Voids Filled with Asphalt (VFA)	N/A		zero tolerance	*
Course Aggregate Angularity (CAA)	zero tolerance		N/A	
Sand Equivalent (SE)	zero tolerance		N/A	
Fine Aggregate Uncompacted Voids (FAA)	zero tolerance		N/A	
%Tensile Strength Ratio (%TSR)	zero tolerance	*	N/A	
Density @ N <sub>ini</sub> and N <sub>max</sub>	N/A		zero tolerance	
Dust to Effective Binder (D/B) Ratio	zero tolerance	*	zero tolerance	*

\* Plot data according to **subsection 106.4**.

For gradations, as a minimum, plot the No. 4, 8, 30 and 200 sieves.

Plot G<sub>mm</sub> to third decimal point.

Indicate Job Mix Formula (JMF) and specification working range limits for single test results on the control charts using a green ink dotted line.

Indicate the specification working range limits for the 4-point moving average results with a green ink solid line.

**d. Mixes with Reclaimed Asphalt Pavement (RAP).** The intent of this section is to prevent more RAP going into a mix than is allowed in the Contract Documents. Totalizers are used to determine the %RAP in mix; however, this does not preclude the Engineer from using other methods for determining the %RAP in a mix.

Provide the Engineer with the totalizer readings at the end of each day of production. These shall include the final daily readings for the RAP, virgin aggregates and asphalt binder.

The %RAP will be checked a minimum of twice a day by the Engineer. Take the readings a minimum of 2 hours apart and a maximum of 6 hours apart. Do not take the readings within the first hour of start-up as adjustments to the plant are most frequent within this time frame.

Calculate RAP percentages using the plant totalizers for the virgin aggregates (AGG<sub>v</sub>), and the RAP as follows:

$$\text{Equation A: } \% \text{RAP} = \frac{\text{RAP} * 100}{\text{RAP} + \text{AGG}_v}$$

%RAP is the percent RAP in the total aggregates (Virgin and RAP) rounded to the nearest tenth.

RAP is the difference between the current and last reading of the RAP totalizer in tons.

AGG<sub>v</sub> is the difference between the current and last reading of the Virgin Aggregate totalizer in tons.

%RAP is considered out of compliance when any of the following occurs:

- Any single test exceeds the maximum percentage allowed by specs by 3%.
- The 4-point moving average exceeds the maximum percentage allowed by specifications.

Actions to be taken if the %RAP is out of compliance:

- If any single test exceeds 3% of the maximum allowed %RAP stop production, perform the “0 check run” on the belts in the presence of the Engineer, and make adjustments to correct the discrepancy.
- If the 4-point moving average exceeds the maximum allowed %RAP three consecutive times, stop production, perform the “0 check run” on the belts in the presence of the Engineer, and make adjustments to correct the discrepancy.

**602 - HOT MIX ASPHALT (HMA) CONSTRUCTION  
(Quality Control/Quality Assurance (QC/QA))**

- If the 4-point moving average exceeds the maximum allowed %RAP by more than 1% then the Contractor will be assessed the following penalty.

**Equation B:**      Contract Deduct = 
$$\frac{BP * Q * (\%RAP_4 - \%RAP_{max})}{100}$$

Contract Deduct is the Dollar amount to be subtracted from the contract.

BP is the Bid Price of the mix.

Q is the Quantity, in tons, of material represented by the 4-point moving average. This value shall be based on the weigh tickets taken from the time of the 1<sup>st</sup> test of the 4-point moving average through the time of 4<sup>th</sup> test.

%RAP<sub>4</sub> is the 4-point moving average of %RAP.

%RAP<sub>max</sub> is the Maximum %RAP from the Project Special Provision.

Contract Deducts for RAP will be an item added to the contract.

Any time production is stopped due to non-compliant %RAP, restart the 4-point moving average provided the belt had the “0 check run” performed in the presence of the Engineer, and adjustments were made to the mix proportioning to correct previous discrepancies. The initial start-up at the beginning of each work day does not constitute a stop in production due to non-compliant %RAP.

If at any time the Contractor chooses to stop production in order to correct discrepancies in the mix proportioning concerning the %RAP, the most recent data (not to exceed 4 points) will be averaged. If the average exceeds the maximum allowed %RAP by more than 1% then a Contract Deduct will be assessed as calculated above with the following substitutions:

In the case where less than 4-points are available for the 4-point moving average, the most recent test is substituted for the 4<sup>th</sup> test, and the %RAP<sub>4</sub> may be a single test, a 2-point moving average or a 3-point moving average.

**e. Mixes with Reclaimed Asphalt Pavement (RAP) and Recycled Asphalt Shingles (RAS).** The intent of this section is to prevent more RAP and RAS going into a mix than is allowed in the Contract Documents. Totalizers are used to determine the %RAP and %RAS in a mix; however, this does not preclude the Engineer from using other methods for determining the %RAP and %RAS in a mix.

Provide the Engineer with the totalizer readings at the end of each day of production. These shall include the final daily readings for the RAP, RAS, virgin aggregates and asphalt binder.

The %RAP and %RAS will be checked a minimum of twice a day by the Engineer. Take the readings a minimum of 2 hours apart and a maximum of 6 hours apart. Do not take the readings within the first hour of start-up as adjustments to the plant are most frequent within this time frame.

Calculate RAP percentages using the plant totalizers for the virgin aggregates (AGG<sub>v</sub>), RAP and the RAS as follows:

**Equation C:**      %RAP = 
$$\frac{RAP * 100}{RAP + RAS + AGG_v}$$

%RAP is the percent RAP in the total aggregates (Virgin, RAP and RAS) rounded to the nearest tenth.

RAP is the difference between the current and last reading of the RAP totalizer in tons.

RAS is the difference between the current and last reading of the RAS totalizer in tons.

AGG<sub>v</sub> is the difference between the current and last reading of the Virgin Aggregate totalizer in tons.

%RAP is considered out of compliance when any of the following occurs:

- Any single test exceeds 13%.
- The 4-point moving average exceeds 10%.

Actions to be taken if the %RAP is out of compliance:

- If any single test exceeds 13% stop production, perform the “0 check run” on the belts in the presence of the Engineer, and make adjustments to correct the discrepancy.

**602 - HOT MIX ASPHALT (HMA) CONSTRUCTION  
(Quality Control/Quality Assurance (QC/QA))**

- If the 4-point moving average exceeds 10% three consecutive times, stop production, perform the “0 check run” on the belts in the presence of the Engineer, and make adjustments to correct the discrepancy.
- If the 4-point moving average exceeds 11% then the Contractor will be assessed the following penalty.

**Equation D:**      Contract Deduct =  $\frac{BP * Q * (\%RAP_4 - \%RAP_{max})}{100}$

Contract Deduct is the Dollar amount to be subtracted from the contract.

BP is the Bid Price of the mix.

Q is the Quantity, in tons, of material represented by the 4-point moving average. This value shall be based on the weigh tickets taken from the time of the 1<sup>st</sup> test of the 4-point moving average through the time of 4<sup>th</sup> test.

%RAP<sub>4</sub> is the 4-point moving average of %RAP.

%RAP<sub>max</sub> is 10%.

Calculate RAS percentages using the plant totalizers for the virgin aggregates (AGG<sub>v</sub>), RAP and the RAS as follows:

**Equation E:**      %RAS =  $\frac{RAS * 100}{RAP + RAS + AGG_v}$

%RAS is the percent RAS in the total aggregates (Virgin, RAP and RAS) rounded to the nearest tenth.

RAP is the difference between the current and last reading of the RAP totalizer in tons.

RAS is the difference between the current and last reading of the RAS totalizer in tons.

AGG<sub>v</sub> is the difference between the current and last reading of the Virgin Aggregate totalizer in tons.

%RAS is considered out of compliance when any of the following occurs:

- Any single test exceeds 6%.
- The 4-point moving average exceeds 5%.

Actions to be taken if the %RAS is out of compliance:

- If any single test exceeds 6% stop production, perform the “0 check run” on the belts in the presence of the Engineer, and make adjustments to correct the discrepancy.
- If the 4-point moving average exceeds 5% three consecutive times, stop production, perform the “0 check run” on the belts in the presence of the Engineer, and make adjustments to correct the discrepancy.
- If the 4-point moving average exceeds 6% then the Contractor will be assessed the following penalty.

**Equation F:**      Contract Deduct =  $\frac{BP * Q * 5 * (\%RAS_4 - \%RAS_{max})}{100}$

Contract Deduct is the Dollar amount to be subtracted from the contract.

BP is the Bid Price of the mix.

Q is the Quantity, in tons, of material represented by the 4-point moving average. This value shall be based on the weigh tickets taken from the time of the 1<sup>st</sup> test of the 4-point moving average through the time of 4<sup>th</sup> test.

%RAS<sub>4</sub> is the 4-point moving average of %RAS.

%RAS<sub>max</sub> is 5%.

The deduct for RAP and RAS will each be paid for under a separate Contract Deduct bid item.

Any time production is stopped due to non-compliant %RAP or %RAS, restart the 4-point moving average provided the belt had the “0 check run” performed in the presence of the Engineer, and adjustments were made to the mix proportioning to correct previous discrepancies. The initial start-up at the beginning of each work day does not constitute a stop in production due to non-compliant %RAP or %RAS.

## **602 - HOT MIX ASPHALT (HMA) CONSTRUCTION (Quality Control/Quality Assurance (QC/QA))**

If at any time the Contractor chooses to stop production in order to correct discrepancies in the mix proportioning concerning the %RAP or %RAS, the most recent data (not to exceed 4 points) will be averaged. If the average exceeds the maximum allowed %RAP or %RAS by more than 1% then a Contract Deduct will be assessed as calculated above with the following substitutions:

In the case where less than 4-points are available for the 4-point moving average, the most recent test is substituted for the 4<sup>th</sup> test, and the moving average may be a single test, a 2-point moving average or a 3-point moving average.

### **602.6 COMPACTION TESTING**

**a. General.** Make the density determination of the compacted mixture using test results on random samples selected by the Contractor or Engineer (see **subsection 602.2i.(1)**) from each lift placed. Select sites according to the approved QCP. Take the nuclear density tests or core samples before placement of the next lift and before opening to construction or public traffic, and no later than the next working day following the date of placement.

Exception to coring after any traffic on the overlay. Do not use this procedure more than twice on any one project or tied projects, unless approved by the Engineer. The Contractor may request re-evaluation by coring. (Testing and coring shall be subsidiary items.) When coring is requested, the follow these procedures for the lot under re-evaluation.

(1) Immediately prior to coring, determine nuclear gauge densities in the presence of the Engineer in the locations previously tested. The average nuclear gauge density after traffic will be determined. A Contractor density correction factor will be calculated as follows: the average nuclear gauge density after traffic minus the average nuclear gauge density before traffic. If the calculated Contractor density correction factor is a negative value, the Contractor's density correction factor will be set equal to zero (normally the density correction factor will be a positive number).

(2) Immediately before coring, nuclear gauge densities will be determined by the Engineer in the presence of the Contractor in the locations previously tested. The average nuclear density after traffic will be determined. A KDOT density correction factor will be calculated as follows, the average nuclear gauge density after traffic minus the average nuclear gauge density before traffic. If the calculated KDOT density correction factor is a negative number, KDOT's density correction factor will be set equal to zero.

(3) Determine the Traffic Density Correction Factor. It will be the larger of the Contractor's density correction factor or KDOT's density correction factor determined in **subsections 602.6a.(1)** and **(2)**.

(4) With the Engineer present, obtain 1 core from each of the Contractor and KDOT nuclear gauge locations. Mark each core as they are taken. Take the cores to KDOT's field laboratory for drying and evaluation. Together, the Contractor and Engineer will determine the density of each core. Determine the corrected core density for each Contractor and KDOT core as follows: the core density minus the Traffic Density Correction Factor.

(5) Using the corrected Contractor core densities and the corrected KDOT core densities, the Engineer will re-evaluate this lot using the procedures outlined in **subsection 602.9**. Based on this re-evaluation, the Engineer will inform the Contractor of the lots disposition and density pay adjustment factor.

For shoulders with a plan width of less than or equal to 3 feet and placed at the same time as the traveled way, the density pay adjustment factors for the traveled way applies. Acceptance of or pay adjustment for density on all shoulders with a plan width greater than 3 feet and any shoulder not placed at the same time as the traveled way shall be according to **subsection 602.9**.

A lot consists of a day's production for each lift placed and contains the number of density locations as outlined in **TABLE 602-11**. Base lot acceptance on 2 test results from each subplot unless the Engineer's results (1 test per subplot) are used.  $V_a$  lots and density lots are normally of different sizes.

If the lane being placed is to be opened to traffic that day, the Engineer and the Contractor may predetermine the subplot size based on anticipated production. If actual production does not meet anticipated production, the subplot size will be adjusted. The number of tests shall be as outlined in **TABLE 602-11**.

The minimum number of density tests is as listed in **TABLE 602-11**. The Contractor has the option to take additional tests to provide 10 test results to determine payment. The density pay adjustment factors are computed using formulas in **subsection 602.9**. The density pay adjustment factors do not apply to sideroads, entrances, crossovers and other incidental surfacing.

**b. Nuclear Density Tests (For mixes with a specified thickness of 1½ inches or greater.).** Take 2 nuclear density tests at random within each subplot. The Engineer will take 1 random nuclear density verification test

**602 - HOT MIX ASPHALT (HMA) CONSTRUCTION**  
**(Quality Control/Quality Assurance (QC/QA))**

per subplot. Perform nuclear density testing to be used in the determination of the traveled way pay adjustment factors and control of shoulder density. Do not take nuclear gauge readings within 1 foot of a longitudinal joint or edge, nor within 20 feet of a transverse joint. For shoulders with a plan width of less than or equal to 3 feet, and placed at the same time as the traveled way, do not take nuclear density readings on the shoulder nor within 1 foot of the shoulder unless the pavement section is uniform across the entire roadway. Mark the outline of the nuclear gauge on the pavement at each location tested with a method of marking that shall last a minimum of 24 hours. Take the nuclear density test at the random location. Do not move the gauge from this location to maximize or minimize the density results. If the Contractor doubts the accuracy of any of the nuclear density test results, the pavement may be cored at the nuclear gauge test locations. If coring is chosen to determine the density for pay adjustment purposes, then all nuclear density test results representing the lot shall be voided and cores taken as prescribed in **subsection 602.6c**.

Take verification nuclear density tests, 1 per subplot, at random locations selected by the Engineer. Payment factors will be based on the Contractor's nuclear density test results, provided those results are validated by KDOT's nuclear density tests.

The Engineer will determine a calibration factor for the Contractor's nuclear density device at the same time as a calibration factor is determined for KDOT's device. The Contractor will be afforded the opportunity to observe the calibration procedure whether it is performed at the district laboratory or on the project site. The Engineer should provide calibration factors by the end of the working day following the date of collecting the cores. In cases where this is not possible, the Contractor and the Engineer may agree in advance to accept a zero pay adjustment for the concerned lots.

The Engineer and Contractor will compare nuclear density test results before any traffic is allowed on the roadway. If the Contractor or KDOT density values are suspect, the Engineer may approve re-testing the locations in question. When re-testing is approved, substitute the new nuclear density values for the values in question. Before traffic is allowed on the roadway, the Contractor needs to determine if cores will be taken.

**c. Cores (For mixes with a specified thickness of 1½ inches or greater.)** Take 2 cores at random locations within each subplot. It may be necessary to chill the compacted mixture before coring so that the samples may be removed intact without distortion. Cut the samples using a 4-inch coring device, unless a 6-inch coring device is approved by the Engineer. Mark all samples with the lot number, subplot number and core number.

Transport the cores to the laboratory as soon as possible to prevent damage due to improper handling or exposure to heat. Cut all cores including the Engineer's verification cores. The Contractor will be paid only for cores cut to calibrate the nuclear gauge, when requested by the Engineer. Use KT-15 Procedure III to determine core density.

Do not take cores within 1 foot of a longitudinal joint or edge, nor within 20 feet of a transverse joint. For shoulders with a plan width of less than or equal to 3 feet, and placed at the same time as the traveled way, do not take cores on the shoulder nor within 1 foot of the shoulder unless the pavement section is uniform across the entire roadway.

Take 1 verification core per subplot (at locations selected by the Engineer) for testing at KDOT's laboratory. Density pay adjustment factors and control of shoulder density are based on the core results, provided those results are validated by the verification cores sent to KDOT's laboratory.

Dry the core holes, tack the sides and bottom, fill with the same type of material and properly compact it by the next working day.

**602.7 WEATHER LIMITATIONS**

Do not place HMA on any wet or frozen surface or when weather conditions otherwise prevent the proper handling and finishing of the mixture.

Only place HMA when either the minimum ambient air temperature or the road surface temperature shown in **TABLE 602-13** is met.

**602 - HOT MIX ASPHALT (HMA) CONSTRUCTION  
(Quality Control/Quality Assurance (QC/QA))**

<b>TABLE 602-13: MINIMUM HMA PLACEMENT TEMPERATURES</b>							
<b>Paving Course</b>	<b>Thickness (inches)</b>	<b>Air Temperature (°F)</b>			<b>Surface Temperature (°F)</b>		
		<b>HMA</b>	<b>WMA Foam</b>	<b>WMA Chem</b>	<b>HMA</b>	<b>WMA Foam</b>	<b>WMA Chem</b>
Surface	All	50	45	40	55	50	45
Subsurface	<1.5	50	45	40	55	50	45
Subsurface	≥1.5 and < 3	40	35	30	45	40	35
Subsurface	≥ 3	30	30	30	35	32	32

**602.8 MIXTURE ACCEPTANCE**

**a. General.** Test each mix designation at each plant for compliance with **TABLE 602-1**. Acceptance will be made on a lot by lot basis contingent upon satisfactory test results. Obtain test samples of the mix designation from the roadway behind the paving operation before compaction. The sampling device and procedures used to obtain the samples must be approved by the Engineer. Use KT-25 for obtaining HMA from the roadway and splitting of the sample. The Contractor’s quality control tests will be used for acceptance provided those results are verified by KDOT.

A load or loads of mixture which, in the opinion of the Engineer, are unacceptable for reasons such as being segregated, aggregate being improperly coated, foaming aggregate or being outside the mixing temperature range may be rejected. Verification samples will be taken by the Engineer at randomly selected locations from behind the paver. Fill all sample locations before compaction.

The  $V_a$  test values will also be used to determine  $V_a$  pay adjustments according to **subsection 602.9d**.  $V_a$  pay adjustments apply to the HMA placed on the traveled way and shoulders (including ramps and acceleration and deceleration lanes).

**b. Lot Definition for Mix Production Sampling and Testing.** A lot is defined as an isolated quantity of a specified material produced from a single source or operation. Each lot shall normally be represented by 4 contiguous test results. A lot may be represented by test results on samples taken from 1 or more day’s production.

**c. Lot Investigation.** The Engineer may examine materials represented by individual test results which lie beyond the Contractor’s normal quality control testing variation. The investigation may be based on either Contractor or KDOT test results. The information from additional testing (including testing of in-place HMA) may be used to define unacceptable work according to **SECTION 105**. The Engineer may apply appropriate price reductions or initiate corrective action.

For any test, if a dispute exists between the Engineer and Contractor about the validity of the other’s test results, the KDOT District Materials Laboratory or the MRC will perform referee testing, except for nuclear density dispute resolution and  $V_a$  dispute resolution. If the disputed KDOT test results were generated at the District Laboratory, the MRC will perform the referee tests. If the disputed KDOT test result was generated at the MRC, an independent laboratory agreeable to both parties will be selected. The Laboratory shall be accredited by the AASHTO Accreditation Program in the appropriate testing category.

If referee testing indicates that KDOT test results are correct, the Contractor pays for the additional testing, including referee testing performed at the MRC. This will be paid using the bid item Contract Deduct which will be an item added to the contract.

If the referee testing indicates that Contractor test results are correct, KDOT pays for the additional testing. Pay the independent lab for the testing and submit the paid invoice to KDOT. The Engineer will reimburse the Contractor (based on the invoice price) as Extra Work, **SECTION 104**.

(1) For nuclear density dispute resolution (the statistical comparison fails and the Contractor questions KDOT’s results), the following procedure applies:

- Discard pay factors previously established with the nuclear gauge, and use the core results to establish the pay factors.
- With the Engineer present, take 1 core from each of the locations previously tested with the Contractor’s nuclear gauge and KDOT’s nuclear gauge (normally 15 cores). Mark all cores with the lot number, subplot number and core number.

**602 - HOT MIX ASPHALT (HMA) CONSTRUCTION**  
**(Quality Control/Quality Assurance (QC/QA))**

- Take the cores to the field laboratory and dry to a constant weight before testing. The Contractor and the Engineer, working together, will determine the core densities (KT-15, Procedure III).
- A statistical comparison will be made between Contractor and KDOT core results. If the t-test passes, KDOT will pay for all cores. The Contractor's test results will be used to calculate the density pay factors. If the t-test fails, KDOT will not pay for the cores. KDOT test results will be used to calculate the density pay factors.

(2) For  $V_a$  dispute resolution (the statistical comparison fails and the Contractor questions KDOT results), the following procedure applies for the lots in question:

- Determine which lots to dispute. Only dispute the lot produced immediately prior to the lot currently under production and being tested. Notify the Engineer, prior to the completion of all Contractor  $V_a$  testing for this lot. (When production is completed for any mix, the last lot may be challenged the day production is completed). When the hot mix plant shuts down for the winter, the Contractor has a maximum of 7 calendar days to dispute the last lot produced prior to winter shut down.
- Discard  $V_a$  and  $V_a$  pay adjustment factors previously determined within the lots being questioned.
- All saved gyratory compacted  $V_a$  quality control and verification samples and back half of samples within the lots in question will be taken by KDOT to the District Materials Laboratory. All back half of samples shall be a minimum of 35 pounds. Failing to obtain enough material removes the right to dispute resolution. Copies of all paperwork, including work sheets, associated with previous  $V_a$  calculations for the disputed lots will also be taken to the District Materials Laboratory.

The following retesting will be completed by KDOT:

- Check the samples to be sure they are dry before retesting. Reweigh the original gyratory compacted  $V_a$  quality control and verification samples. Determine the  $G_{mb}$  at  $N_{des}$  revolutions for all saved gyratory plugs. Compare retest results with original test results. Use this information to isolate potential testing errors, but continue with the remainder of the retesting steps.
- Determine the  $G_{mm}$  using the back half of all samples within each lot being questioned. Normally, there will be 5 back halves (4 Contractor's and 1 KDOT) to test within each lot.
- Compact the back halves to  $N_{max}$  revolutions and determine the  $G_{mb}$  at  $N_{des}$  revolutions.
- Use  $G_{mm}$  determined above and the  $G_{mb}$  determined from the recompacted samples to calculate  $V_a$  at  $N_{des}$  revolutions for the lots in question.
- Using the retest  $V_a$  results, a statistical comparison will be made. If the t-test passes, the Contractor's retest results will be used to calculate the pay factor and KDOT will pay for all retesting. Use the procedures shown in **subsection 602.9d**. If the t-test fails, KDOT's retest results will be used to calculate the pay factor, and the Contractor will pay for all retesting.

**d. Resampling of Lots.** Take no samples for retest for pay adjustment purposes except as noted in **subsections 602.6b.** and **602.8c.**

**e. Multiple Projects.** If multiple projects are supplied from 1 or more plants using the same mix, carry over the lots at each hot mix plant from project to project.

**f. Lot Size.** A standard size mix production lot (density test lots are defined in **subsection 602.6a.(5)**) consists of 4 equal sublots of 750 tons each of HMA (lot size is 3,000 tons).

It is anticipated that lot size shall be as specified. However, with the Engineer's approval, the Contractor may re-define lot size for reasons such as, but not limited to, change in contract quantities or interruption of the work. Take 1 sample during production of each subplot and utilize it to determine disposition of the lot in which it occurs.

**g. Increased Lot Size.** After 8 consecutive sublots have been produced within the tolerance shown for all mix characteristics listed in **TABLE 602-12** and without a  $V_a$  penalty, the subplot size may be increased to 1,000 tons (lot size of 4,000 tons), provided the normal production rate of the plant is greater than 250 tons per hour. Provide immediate notification of lot size changes to the Engineer any time a change is made.

After 8 additional consecutive sublots have been produced at the 1,000 ton subplot size, the subplot size may again be increased to 1,250 tons per subplot ( lot size of 5,000 tons), provided all 8 consecutive 1,000 ton sublots have been produced within the tolerances shown for all mix characteristics listed in **TABLE 602-12**, without a  $V_a$



**602 - HOT MIX ASPHALT (HMA) CONSTRUCTION  
(Quality Control/Quality Assurance (QC/QA))**

penalty, production rates for the previous 2 days have been greater than 3,750 tons per day, and a minimum of 2 of the last 3 segregation profile checks comply with **TABLE 602-14**.

<b>TABLE 602-14: SEGREGATION PROFILE CHECKS FOR INCREASED SUBLOT SIZE</b>		
<b>Mix Designation</b>	<b>Maximum Density Range (highest minus lowest)</b>	<b>Maximum Density Drop (average minus lowest)</b>
All	3.1 lbs./cu. ft.	1.9 lbs./cu. ft.

If subsequent test results fall outside the tolerances shown for any mix characteristic listed in **TABLE 602-12** or a  $V_a$  penalty is incurred, decrease the subplot size to 750 tons. If the production rates fall below 3,750 tons per day for 2 consecutive days or a minimum of 2 of the last 3 segregation profile checks fail the above requirements, then reduce the 1,250 ton sublots size to 1,000 ton per subplot provided the **TABLE 602-12** criteria is met and no  $V_a$  penalty is incurred.

When the increased lot size criteria are again met for 4 consecutive sublots, the subplot may be increased as the limits given above.

**h. Decreased Lot Size for Small Quantities.** This is to be used when a small quantity (less than 3,000 tons) of a particular mix will be used. Use the plan quantity for the lot size. Reduce the subplot size below 750 tons by dividing the lot into 3 or 4 equal sublots. Before beginning production, provide the Engineer with the number and size of the sublots.

**i. Pre-Production Mix.** Test and evaluate a pre-production mix, limited to a maximum of 200 tons from each plant and type of mix before production of that mix. Evaluate the pre-production mix at initial start-up and after suspension of production resulting from failing test results. Do not adjust  $V_a$  payment for pre-production mixes. Provide a pre-production mix that complies with the gradation, D/B ratio, binder content, VMA, level of compaction for  $N_{ini}$ ,  $N_{des}$ ,  $N_{max}$  and laboratory  $V_a$  requirements prior to starting or resuming production. For binder content,  $V_a$  at  $N_{des}$  and VMA, use the "Single Test Value" listed in **TABLE 602-12** for comparison. For the other tests listed, use the values listed in **TABLE 602-1** for each mix. Except for initial start-up, normal delivery of material to the project before completion of certain test results on pre-production mixes may be authorized by the DME.

Place the material produced for the pre-production mix in locations approved by the DME. On projects where HMA is paid by the ton, consider placing the pre-production mix in non-critical areas such as side roads, entrances, shoulders or deep in the base. The Engineer will pay for material as the material produced, not in the location placed. However to prevent potential cost overruns, do not run an excessive number of "higher cost" pre-production mixes (as determined by the Engineer) on shoulders or entrances.

On projects in which the HMA is paid by the square yard, place pre-production mixes where required by the Contract Documents. A higher quality pre-production mix may be placed at no additional expense to KDOT. If HMA materials which are designated to be placed in the top 4 inches of the pavement structure are placed deeper than 4 inches as a pre-production mix, do not count the material toward the requirement to place the material in the top 4 inches of the pavement section.

At the direction of the Engineer, remove the pre-production mix if it is both out of specification and the material shortens the pavement life or changes the intended function. The Engineer will pay for the replacement of one pre-production mix at 100% of the contract unit price for each mix in the contract (not each mix design). If the HMA is paid by the square yard, then the removed material will be paid for at a rate of \$40 per ton. The Engineer will create a change order (**SECTION 104**) adding the item of work with a unit price of \$40/ton. The payment will be full compensation to the Contractor for the placement and removal of that pre-production mix. KDOT will not be financially responsible for any subsequent failed pre-production mixes (that require removal) for that mix. The removed material is the property of the Contractor.

The Engineer will not pay for pre-production mixes that are required to be replaced due to poor workmanship or equipment failure. The Engineer will make the final decision to remove a failed pre-production mix with input from the Contractor.

**j. Suspension of Mix Production.** Suspend production of the mix until appropriate corrections have been made, if 2 consecutive test results for any single mix characteristic fail to fall within the limits established by the tolerances shown in the single test value column of **TABLE 602-12**. Additionally, suspend production of the mix

**602 - HOT MIX ASPHALT (HMA) CONSTRUCTION  
(Quality Control/Quality Assurance (QC/QA))**

until appropriate corrections have been made, if any 4-point moving average value for any single mix characteristic fails to fall within the limits established by the tolerances shown in the 4-point moving average value column of **TABLE 602-12**. Production remains suspended pending the satisfactory results of a pre-production mix, unless waived by the DME.

The Engineer may stop production of HMA at any time the mix or process is determined to be unsatisfactory. Make the necessary corrections before production will be allowed to resume. Failure to stop production of HMA subjects all subsequent material to rejection by the Engineer, or acceptance at a reduced price, as determined by the Engineer.

**602.9 BASIS OF ACCEPTANCE**

**a. General.** Acceptance of the mixture will be contingent upon test results from both the Contractor and KDOT. The Engineer will routinely compare the variances (F-test) and the means (t-test) of the verification test results with the quality control test results for  $V_a$ ,  $G_{mm}$  and density using a spreadsheet provided by KDOT. If KDOT verification test results do not show favorable comparison with the Contractor's quality control test results, then KDOT test results will be used for material acceptance, material rejection and the determination of any pay adjustment on the  $V_a$  and roadway density. Disputed test results will be handled according to **subsection 602.8c**.

KDOT will use a spreadsheet program to calculate pay adjustments for density and  $V_a$ , and to compare Contractor QC and KDOT QA test results (including  $G_{mm}$ ). KDOT will provide a copy of this program to the Contractor, when requested. Microsoft Excel software is required to run this program; it is the Contractor's responsibility to obtain the correct software. Values computed using equations referenced in this specification may vary slightly from the spreadsheet values due to rounding of numbers. In such cases, the numbers computed by the spreadsheet will govern.

The comparison of quality control and verification tests will be completed using the t-tests to compare their population means and the F-test to compare their variances. The F & t tests, along with the Excel Spreadsheet used to compare the Contractor's QC results and KDOT's QA results, are described in Section 5.2.6 – Comparison of Quality Control and Verification Tests, Part V. (Examples of Air Voids F & t tests, along with Density F & t tests are shown in this section.) Additional information on the program may be obtained from the Bureau of Construction and Materials.

**b. Asphalt Density Pay Adjustment for "HMA Overlay" Bid Items.** Mixes with specified thickness of less than 1½ inches are not subject to the asphalt density pay adjustments.

For mixes with specified thickness of 1½ inches or greater: Asphalt density pay adjustment for compaction of the completed pavement shall be by lot, based on the percentage of  $G_{mm}$  obtained. Compute the asphalt density pay adjustment (incentive or disincentive) by multiplying the density pay adjustment factor ( $P_D$ ) times the number of tons included in the lot times \$40 per ton. (Air voids lots and density lots are normally of different sizes.) This adjustment will be paid for under the bid item Asphalt Density Pay Adjustment.

Density pay factors will be determined from **TABLE 602-15**. (For **TABLE 602-15**, average the percent of  $G_{mm}$  values to 0.01% and calculate the density pay adjustment factors rounded to the thousandths).

<b>TABLE 602-15: DENSITY PAY FACTORS FOR SPECIFIED THICKNESS<sup>4</sup></b>			
<b>Specified Thickness →</b>	<b>≥ 2"</b>	<b>≥ 1½"</b>	
	<b>All</b>	<b>Continuous Action<sup>5</sup></b>	<b>No Continuous Action<sup>6</sup></b>
<b>% of <math>G_{mm}</math> Average of 10 Density Tests<sup>1</sup></b>	<b>Pay Factor<sup>2</sup></b>		<b>Pay Factor<sup>2</sup></b>
93.0% or greater	1.040		1.040
92.0 to 92.9%	A1		A1
91.0 to 91.9%	1.000		1.000
90.0 to 90.9%	A2		1.000
89.0 to 89.9%	0.840 or Remove <sup>3</sup>		A3
less than 89.0%	0.840 or Remove <sup>3</sup>		0.840 or Remove <sup>3</sup>

<sup>1</sup>For low daily production rates less than 1000 tons, or when the Engineer's verification tests are to be used for asphalt density pay determination, the lot sample size is as determined in **TABLE 602-11**.

**602 - HOT MIX ASPHALT (HMA) CONSTRUCTION  
(Quality Control/Quality Assurance (QC/QA))**

<sup>2</sup>Shoulders: For shoulders with a plan width greater than 3 feet and any shoulder not placed at the same time as the traveled way, compact the HMA in the lot to a minimum of 90.00% (if specified thickness is  $\geq 2$ " ) or 89.00% (if the specified thickness is from 1½" to 1⅞") of the  $G_{mm}$ . Otherwise, the Engineer will determine whether the HMA in the lot may remain in place or be removed. Any such material left in place shall have a density pay factor of 0.950 or less.

<sup>3</sup>Low Density: The Engineer will determine if the traveled way, shoulders with a plan width of 3 feet or less and placed with the traveled way, ramps, acceleration and deceleration lanes may remain in place or be removed. The Engineer will notify the Contractor before 11:00 AM of the next working day if the area is to be removed. Any such material left in place shall have a density pay factor of 0.840.

<sup>4</sup>Specified thickness is the total thickness shown in the Contract Documents for the mix being placed.

<sup>5</sup>Use for  $\geq 1\frac{1}{2}$ " when another continuous action, such as milling, surface recycling, cold recycling or overlay is completed ahead of this overlay.

<sup>6</sup>Use for  $\geq 1\frac{1}{2}$ " when another continuous action is not completed before the overlay.

**Calculations for Density Pay Factors A1, A2 and A3:**

$$A1 = [100 + 4 (\% \text{ of lot } G_{mm} - 92.00)] \div 100$$

$$A2 = [84 + 16 (\% \text{ of lot } G_{mm} - 90.00)] \div 100$$

$$A3 = [84 + 16 (\% \text{ of lot } G_{mm} - 89.00)] \div 100$$

**Density Pay Adjustment Factor Calculation:**

$$\text{Density Pay Adjustment Factor } (P_D)^* = \text{Density Pay Factor} - 1.000$$

\* $P_D$  rounded to the nearest thousandth

**c. Asphalt Density Pay Adjustment for "HMA Surface", "HMA Base" and "HMA Pavement" Bid Items.** Asphalt Density Pay Adjustment for compaction of the completed pavement shall be by lot, based on the percentage of  $G_{mm}$  obtained. This adjustment will be paid for under the bid item Asphalt Density Pay Adjustment. Compute the Asphalt Density Pay Adjustment (positive or negative) by multiplying the Density Pay Adjustment factor ( $P_D$ ) times the number of tons included in the lot times \$40 per ton. The Asphalt Density Pay Adjustment will be added or subtracted on the pay estimate. For shoulders with a plan width of less than or equal to 3 feet, and placed at the same time as the traveled way, the  $P_D$  for the traveled way will apply. The  $P_D$  does not apply to sideroads, entrances, crossovers and other incidental surfacing. Use KDOT test results for the lot to determine the  $P_D$  when the statistical comparison between the quality control and the verification tests fail (see **subsection 602.9a.**).

**Lot Size:** A lot shall normally be comprised of the results of 10 tests performed on a day's placement of a given mix placed in a given lift. Lot size is defined in **subsection 602.6.** (Air void lots and density lots are normally of different sizes).

**Shoulders:** For all shoulders with a plan width greater than 3 feet and any shoulder not placed at the same time as the traveled way, the lower specification limit (LSL) is 90.00%. When the lower percent within limits ( $PWL_{LD}$ ) is 50.00% or more for the lot,  $P_D$  is zero. When the  $PWL_{LD}$  is less than 50.00% for the lot, the Engineer will determine whether the HMA in the lot may remain in place or be removed. Any such material left in place will have a  $P_D$  of -0.050, unless the Engineer establishes lower values for  $P_D$  (-0.100, -0.200, -0.300, etc.) as a condition of leaving the material in place.

Determination of  $P_D$  and  $PWL_{LD}$ : Calculate the lower density quality index ( $Q_{LD}$ ) for each lot using Equation 1 and round to hundredths. Locate the  $Q_{LD}$  value in the left column of the Percent Within Limits (PWL) Table in Section 5.2.1 - Statistics, Part V. Select the appropriate  $PWL_{LD}$  value by moving across the selected quality index row to the column representing the number of samples in the lot.

If  $Q_{LD}$  is greater than the largest quality index value shown in the table, use 100.00 as the value for  $PWL_{LD}$ .

If  $PWL_{LD}$  is less than 50.00% for the lot, the Engineer will determine if the material in the lot may remain in place. If the material is left in place, the value of  $P_D$  for the lot will be equal to -0.160, unless the Engineer establishes lower values for  $P_D$  (-0.200, -0.300, etc.) as a condition of leaving the material in place. Otherwise, calculate  $P_D$  using Equation 2 and round to thousandths.

**Equation 1:** 
$$Q_{LD} = \frac{\bar{X} - LSL}{S}$$

$\bar{X}$  is the average measured percent of  $G_{mm}$  of all samples within a lot rounded to hundredths.

LSL is the lower specification limit for density and is defined as 91.00% of  $G_{mm}$  for traveled way plan thickness 2 inches and less and 92.00% of  $G_{mm}$  for traveled way plan thickness greater than 2 inches.

**602 - HOT MIX ASPHALT (HMA) CONSTRUCTION  
(Quality Control/Quality Assurance (QC/QA))**

S is the standard deviation of the measured density of all samples within a lot and is calculated using equation (4) in Section 5.17.09, Part V, rounded to hundredths.

**Equation 2:** 
$$P_D = (PWL_{LD} * 0.004) - 0.360$$

**d. Asphalt Air Void Pay Adjustment.** Asphalt Air Void ( $V_a$ ) Pay Adjustment will be made on a lot basis and based on measured  $V_a$  from samples of plant produced material. This adjustment will be paid for under the bid item Asphalt Air Void Pay Adjustment. The  $V_a$  pay adjustment factor ( $P_V$ ) (positive or negative) will be determined and used to compute the  $V_a$  Pay Adjustment by multiplying  $P_V$  times the number of tons included in the lot times \$40 per ton. The  $V_a$  Pay Adjustment will be added or subtracted on the pay estimate. When the statistical comparison between the quality control and the verification tests pass, use the procedures in **subsection 602.9d.(1)** to compute  $P_V$ . When the statistical comparison fails, calculate  $P_V$  using procedures in **subsection 602.9d.(2)**.

**Lot Size:** A lot shall normally be comprised of the results of 4 contiguous individual  $V_a$  tests performed on gyratory compacted samples of a given mix design. Lot size is defined in **subsections 602.8f, 602.8g, and 602.8h**. When there are 1 or 2 tests remaining, such as at the end of a project or season, combine them with the previous 4 tests to create a 5 or 6 test lot, respectively. When there are 3 tests remaining, combine the 3 tests into a lot. (Air voids lots and density lots are normally of different sizes).

(1) Air Voids Pay Adjustment Factor (Passing t-test). Calculate the upper and lower  $V_a$  quality indices ( $Q_{UV}$  and  $Q_{LV}$ ) for each lot using Equations 3 and 4, respectively and round to hundredths. Locate the  $Q_{UV}$  value in the left column of the Percent Within Limits (PWL) Table in Section 5.2.1 – Statistics, Part V. Select the appropriate upper percent within limit value ( $PWL_{UV}$ ) by moving across the selected quality index row to the column representing the number of samples (N) in the lot. Repeat the process using the  $Q_{LV}$  value and select the appropriate value for the lower percent within limits ( $PWL_{LV}$ ). If the  $Q_{UV}$  or  $Q_{LV}$  value is greater than the largest quality index value shown in the table, then a value of 100.00 is assigned as the value for  $PWL_{UV}$  or  $PWL_{LV}$ , respectively. If both  $Q_{UV}$  and  $Q_{LV}$  exceed the values shown in the table, a value of 100.00 is assigned as the value for both  $PWL_{UV}$  and  $PWL_{LV}$ . If either  $Q_{UV}$  or  $Q_{LV}$  is a negative value or  $PWL_{UV} + PWL_{LV}$  is less than 150.00, the Engineer will determine if the material in the lot may remain in place. If the Engineer determines that the material may remain in place then the maximum value of  $P_V$  for the lot will be equal to -0.120. The Engineer may establish lower values for  $P_V$  (-0.200, -0.300, etc.) in such instances. Otherwise, calculate  $P_V$  using Equation 5 and round to thousandths.

**Equation 3:** 
$$Q_{UV} = \frac{USL - \bar{X}}{S}$$

**Equation 4:** 
$$Q_{LV} = \frac{\bar{X} - LSL}{S}$$

$\bar{X}$  is the average measured  $V_a$  of all samples within a lot rounded to hundredths.

USL is the upper specification limit for  $V_a$  and is defined as 5.00%.

LSL is the lower specification limit for  $V_a$  and is defined as 3.00%.

S is the standard deviation of the measured  $V_a$  for all samples within a lot and is calculated using equation (4) in Section 5.2.1 - Statistics, Part V, rounded to hundredths.

**Equation 5:** 
$$P_V = ((PWL_{UV} + PWL_{LV} - 100.00)(0.003)) - 0.270$$

$PWL_{UV}$  is the upper percent within limits value for  $V_a$ .

$PWL_{LV}$  is the lower percent within limits value for  $V_a$ .

(2) Air Voids Pay Adjustment (Failing t-Test). If the t-test fails, KDOT's test result will be used to calculate the  $P_V$  for the lot. Follow the procedures given in **subsection 602.9d.(1)** to determine the  $P_V$  or disposition of the lot. Use the values from **TABLE 602-16** to calculate  $Q_{UV}$ ,  $Q_{LV}$ ,  $PWL_{UV}$  and  $PWL_{LV}$  in Equations 3, 4 and 5 in **subsection 602.9d.(1)**.

**602 - HOT MIX ASPHALT (HMA) CONSTRUCTION  
(Quality Control/Quality Assurance (QC/QA))**

<b>TABLE 602-16: Statistical Values for Air Voids Pay Adjustment for Failing t-Test</b>		
<b>Term</b>	<b>Definition</b>	<b>Value</b>
$\bar{X}$	Average or Mean	KDOT's test result for the lot
S	Standard Deviation	0.50
USL	Upper Specification Limit	5.50%
LSL	Lower Specification Limit	2.50%
N	Sample Size	3

**602.10 DETERMINATION OF THICKNESS, THICKNESS PAY ADJUSTMENT AND AREA PAY ADJUSTMENTS FOR "HMA PAVEMENT" AND "HMA PAVEMENT SHOULDER" BID ITEMS**

**a. General.** Construct the pavement to the dimensions shown in the Contract Documents. Inform the Engineer when a section is ready for coring and measurement of width and length. Complete all paving of the shoulder and driving lanes within this section, unless otherwise approved by the Engineer.

A driving lane is defined as mainline lanes, acceleration lanes (including tapers), deceleration lanes (including tapers), auxiliary lanes, ramp lanes or combination thereof.

When shoulders, medians and widenings are placed monolithically with the adjacent driving lane, and there is not a separate bid item for shoulders, then the shoulders are considered as part of the driving lane, and are subjected to the same unit price adjustment as the driving lane.

**b. Measurements.** The Engineer will divide the projects into lots. A lot is comprised of 5 sublots with the same plan thickness. A subplot is defined as a single driving lane or a single shoulder, with an accumulative length of 1000 feet. If the last lot has 1 or 2 sublots (such as at the end of a project or season), combine them with the previous lot to create a lot with 6 or 7 sublots, respectively. Consider as a single lot if there are 3 or 4 sublots in the final lot.

The Engineer will generate 1 random location for coring within each subplot. Do not take a core within 1 foot of a longitudinal joint or edge. Obtain the cores with the Engineer present.

Take a 4-inch diameter core from the selected sites. Mark each core with its lot and subplot number, and transport to the KDOT field lab.

For information only, the Engineer will determine the thickness of each HMA mixture and the total HMA base for each core.

The Engineer will determine the total core thickness for pay by taking 3 caliper measurements at approximately 120° apart and record each to the nearest 0.1 inch. The average of the 3 caliper measurements rounded to the nearest 0.1 inch shall represent the average measured thickness. The Engineer will use the total pavement thickness measurements to determine thickness pay adjustment factors.

The Engineer will provide a copy of the results to the Contractor before the end of the following working day.

Prior to coring, the Contractor may request that areas trimmed without automatically controlled equipment be handled separately. (This would require the Contractor to designate the area as a lot before knowing the actual core thickness.) When requested and approved by the Engineer, each area will be considered a lot. Divide the area into 5 sublots and obtain 1 core from each subplot.

For Percent Within Limits (PWL) thickness analysis, if any subplot thickness exceeds the design thickness by more than 1.0 inch, the Excel spreadsheet will automatically consider that subplot thickness to be 1.0 inch more than the design thickness. The spreadsheet will recalculate a new lot mean and sample standard deviation based on the adjusted value.

Dry the core holes, tack the sides and bottom, fill them with a HMA mixture (approved for the project) and properly compact it by the end of the next working day.

**c. Deficient Measurements for Driving Lanes.** When any full depth core for driving lanes is deficient by 1.0 inch or greater from the specified thickness, take exploratory cores at intervals a minimum of 50 feet in each direction (parallel to the centerline) from the deficient core.

Continue to take exploratory cores in each direction until a core is taken that is deficient a maximum of 0.5 inch. Exploratory cores are used only to determine the length of pavement in a lot that is to be overlaid, as approved by the Engineer.

**602 - HOT MIX ASPHALT (HMA) CONSTRUCTION  
(Quality Control/Quality Assurance (QC/QA))**

The minimum overlay length (with surface mix) shall be equal to the distance between the cores that are deficient by a maximum of 0.5 inch, and the width to be paved shall be full width of the roadway (driving lanes and shoulders) when this occurs.

The minimum overlay thickness is 3 times the nominal maximum aggregate size.

Complete the overlay to the satisfaction of the Engineer. Mill butt joints on the ends of the overlay area. The Engineer will not pay for any milling costs.

The exploratory cores are not used to determine thickness pay adjustment factors. Randomly select another core (outside the overlay area) to represent the subplot.

**d. Deficient Measurements for Shoulders.** When any full depth core taken from the shoulders is deficient by greater than 1.5 inches, take exploratory cores at intervals a minimum of 50 feet in each direction (parallel to the centerline) from the deficient core.

Continue to take exploratory cores in each direction until a core is only deficient a maximum of 0.8 inches.

Exploratory cores are used only to determine the length of pavement in a lot that is to be removed and replaced, or accepted at a reduced price (in addition to any disincentive assessed on that lot), as approved by the Engineer.

The minimum repair length is equal to the distance between the cores that are deficient a maximum of 0.8 inches, and the full width of the shoulder.

Mill butt joints on the ends of the overlay area. The Engineer will not pay for any milling costs. Unless approved by the Engineer, replacing includes complete removal of all HMA within the area defined by the results of the exploratory cores. Rework, stabilize (if required) and regrade the subgrade. When required, reconstruct the base and replace all HMA mixes shown in the Contract Documents. Obtain 1 random core within this subplot and use its core length to determine the thickness pay adjustment factor.

**e. Asphalt Pavement Area Pay Adjustment.** Determine the areas for pay and pay adjustment as shown in **TABLE 602-18**. The KDOT spreadsheet program will calculate these areas. This adjustment will be paid for under the bid item Asphalt Pavement Area Pay Adjustment.

Irregularly shaped areas may have to be calculated outside the program and the area entered into the program. Compute pay per lot for areas placed and not placed (deducted) as shown in Equations 10, 11, 12 and 13.

**Equation 10:** Pay for Driving Lane =  $(\sum PDLA)(BP)$   
**Equation 11:** Pay Deduct for Driving Lanes =  $2(\sum PDLDA)(BP)$   
**Equation 12:** Pay for Shoulder =  $(\sum PSA)(BP)$   
**Equation 13:** Pay Deduct for Shoulder =  $2(\sum PSDA)(BP)$

$\sum PDLA$  = Pay Driving Lane Area per Lot, Square Yard

$\sum PDLDA$  = Pay Driving Lane Deduct Area per Lot, Square Yard

$\sum PSA$  = Pay Shoulder Area per Lot, Square Yard

$\sum PSDA$  = Pay Shoulder Deduct Area per Lot, Square Yard

BP = Bid Price for either the driving lanes or the shoulder, as applicable

**TABLE 602-17: HMA AREA ABBREVIATIONS**

<b>Abbreviation</b>	<b>Definition</b>	<b>Units</b>
PDLA	= Pay Driving Lane Area per Sublot	Sq Yd
PDLDA	= Pay Driving Lane Deduct Area per Sublot,	Sq Yd
PSA	= Pay Shoulder Area per Sublot	Sq Yd
PSDA	= Pay Shoulder Deduct Area per Sublot	Sq Yd
MDLW	= Measured Driving Lane Width	Ft
MSW	= Measured Shoulder Width	Ft
MTLW	= Measured Total Lane Width (includes shoulder, if any)	Ft
PDLW	= Plan Driving Lane Width	Ft
PSW	= Plan Shoulder Width	Ft
PTLW	= Plan Total Lane Width (includes shoulder, if any)	Ft
EDLW	= Excess Driving Lane Width	Ft
SL	= Sublot Length	Ft

**602 - HOT MIX ASPHALT (HMA) CONSTRUCTION**  
**(Quality Control/Quality Assurance (QC/QA))**

<b>TABLE 602-18: HMA AREA SUBLOT CALCULATIONS<sup>1</sup></b>				
<b>Condition</b>	<b>PDLA<sup>2</sup></b>	<b>PDLDA<sup>2</sup></b>	<b>PSA<sup>2</sup></b>	<b>PSDA<sup>2</sup></b>
	<b>(Sq Yd)</b>	<b>(Sq Yd)</b>	<b>(Sq Yd)</b>	<b>(Sq Yd)</b>
<b>Projects with a Separate Bid Item for Shoulder</b>				
<b>Narrow Driving Lane</b>				
MSW is less than PSW	(SL)(MDLW)	(SL)(PDLW-MDLW)	(SL)(MSW)	(SL)(PSW-MSW)
MSW is greater than PSW	(SL)(MDLW)	(SL)(PDLW-MDLW)	(SL)(MSW <sup>3</sup> )	0
<b>Wide Driving Lane</b>				
MSW + EDLW is less than PSW	(SL)(PDLW)	0	(SL)(MSW+EDLW)	(SL)(PSW-MSW-EDLW)
MSW + EDLW is greater than PSW	(SL)(PDLW)	0	(SL)(MSW+EDLW <sup>4</sup> )	0
<b>Projects without a Separate Bid Item for Shoulder<sup>5</sup></b>				
Narrow Driving Lane and Shoulder	(SL)(MTLW)	(SL)(PTLW-MTLW)	N/A	N/A
Wide Driving Lane and Shoulder	(SL)(MTLW <sup>6</sup> )	0	N/A	N/A

<sup>1</sup>Deductions will be made for unplaced areas.

<sup>2</sup>Calculate the areas to the nearest 0.01 square yards. Measure the lengths and widths to the nearest 0.01 feet. Divide the result of all equations in this table by 9 so that the resulting units are square yards.

<sup>3</sup>MSW shall be between PSW and PSW + 0.25 feet. Any excess width over 0.25 feet will not be included in PSW.

<sup>4</sup>MSW+ EDLW shall be between PSW and PSW + 0.25 feet. Any excess width over 0.25 feet will not be included in PSW.

<sup>5</sup>Shoulder is normally 0.00 feet to 3.00 feet wide and placed at the same time as the driving lane. PTLW = PDLW + PSW

<sup>6</sup>MSTLW shall be between PTLW and PTLW + 0.25 feet. Any excess width over 0.25 feet will not be included for pay.

**f. Asphalt Pavement Thickness Pay Adjustment.** Compute the Asphalt Thickness Pay Adjustment for the driving lanes (TPA<sub>DL</sub>) and shoulders (TPA<sub>SH</sub>) using Equation 6 or 7, respectively. Compute the Asphalt Thickness Pay Adjustment factor (P<sub>T</sub>) as shown in Equation 9. Determine area calculations for the driving lanes and shoulders as shown in **TABLE 602-18**. **TABLE 602-17** provides the definition for the abbreviations used in **TABLE 602-18**. Enter the measured values into the spreadsheet program to determine PDLA and PSA.

This adjustment will be paid for under the bid item Asphalt Pavement Thickness Adjustment.

**Equation 6:**  $TPA_{DL} = P_T (\sum PDLA) (\$1.90) (\text{Plan Thickness})$

**Equation 7:**  $TPA_{SH} = P_T (\sum PSA) (\$1.70) (\text{Plan Thickness})$

TPA<sub>DL</sub> = Thickness Pay Adjustment per Lot for Driving Lane

TPA<sub>SH</sub> = Thickness Pay Adjustment per Lot for Shoulder

∑PDLA = Pay Driving Lane Area per Lot, Square Yard

∑PSA = Pay Shoulder Area per Lot, Square Yard

Plan Thickness = HMA Thickness shown on Plans, Inches

KDOT will use a spreadsheet program to calculate thickness pay adjustments. KDOT will provide a copy of this program to the Contractor, when requested. It is the Contractor's responsibility to obtain the Microsoft Excel software required to run this program. Values computed using equations referenced in this specification may vary slightly from the spreadsheet values due to rounding of numbers. In such cases the numbers computed by the spreadsheet take precedence.

**Thickness Quality Index (Q<sub>T</sub>) Computation.** In each lot, calculate Q<sub>T</sub> for the total pavement thickness using Equation 8 and round to hundredths.

**Equation 8:**  $Q_T = \frac{\bar{X} - LSL}{S}$

**602 - HOT MIX ASPHALT (HMA) CONSTRUCTION  
(Quality Control/Quality Assurance (QC/QA))**

$\bar{X}$  = Average total core length of all samples representing a lot, rounded to the nearest 0.1 inch. (Adjust core length before averaging, as shown in **subsection 602.10b.**)

LSL = Lower specification limit for thickness. For driving lanes use 0.5 inch less than the total plan driving lane thickness shown on the typical section. For shoulders, use 0.8 inch less than the total plan shoulder thickness shown on the typical section.

S = Sample standard deviation of the measured core lengths of all samples representing a lot and is calculated using equation (4) in Section 5.2.1 – Statistics, Part V, rounded to hundredths.

Use the computed  $Q_T$  to determine the thickness Percent Within Limits value ( $PWL_T$ ) by locating the  $Q_T$  in the left column of the Percent Within Limits (PWL) Table in Section 5.2.1 - Statistics, Part V. Select the appropriate  $PWL_T$  by moving across the selected  $Q_T$  row to the column representing the number of samples in the lot.

If the computed  $Q_T$  is a negative value, then the lot and all adjacent areas (full width of roadway) shall be overlaid as determined by the Engineer. After the lot has been overlaid, randomly select another core for each subplot, and calculate a new pay factor. For lots that have been entirely overlaid, the maximum pay factor is zero.

If the computed  $Q_T$  is greater than the largest  $Q_T$  shown in the PWL Table, a value of 100.00 is assigned as the  $PWL_T$  for thickness.

For each lot and all lanes and shoulders, compute the thickness pay factor ( $P_T$ ) for the total pavement thickness using Equation 9 and round to nearest thousandth. No bonus will be paid for shoulders, thus use  $P_T = 0.000$  whenever  $P_T$  calculates greater than 0.000 for shoulders.

**Equation 9:** 
$$P_T = \left( \frac{(PWL_T) * 0.30}{100} \right) - 0.270$$

**g. Minimum Quantity of HMA for Square Yard Projects with "HMA Pavement" and HMA Pavement Shoulder" Bid Items.** For the total project, supply a minimum of 93% of  $G_{mm}$  required by the surface course of driving lanes and shoulders and the top base course of driving lanes and shoulder. Calculate the minimum quantity of those 2 mixes, individually as follows:

**Equation 14:** 
$$\text{Minimum Quantity (Tons)} = \frac{0.93 (A) (T) (G_{mm})}{42.7}$$

A = Area in square yards for each of the mixes.

T = Plan thickness in inches of surface course and the top base course of driving lanes and shoulders.

$G_{mm}$  = Theoretical maximum specific gravity equals the average  $G_{mm}$  value used in the first 5 lots or the average  $G_{mm}$  for ½ of the project (whichever is less) for the 4 mixes listed in "T" in Equation 14. Determine the average  $G_{mm}$  from the Excel worksheet titled "Density F & T Test Worksheet".

If this minimum quantity of surface course or base course is not placed, a deduction of \$40 per ton will apply to the quantity not placed for each mix. This will be paid using the bid item Contract Deduct which will be an item added to the contract.

**602.11 MEASUREMENT AND PAYMENT**

**a. "HMA Base", "HMA Surface" and "HMA Overlay" Bid Items.** The Engineer will measure HMA Base, HMA Surface and HMA Overlay by the ton of material at the time of delivery to the road. Batch weights will not be allowed as a method of measurement unless all the following conditions are met:

- the plant is equipped with an automatic printer system approved by the Engineer;
- the automatic printer system prints the weights of material delivered; and
- the automatic printer system is used in conjunction with an automatic batching and mixing control system approved by the Engineer.

Provide a weigh ticket for each load. Due to possible variations in the specific gravity or weight per cubic foot of the aggregates, the tonnage used may vary from the proposal quantities and no adjustment in contract unit price will be made because of such variances.



**602 - HOT MIX ASPHALT (HMA) CONSTRUCTION**  
**(Quality Control/Quality Assurance (QC/QA))**

Payment for "HMA Base (\*)(\*\*)(\*\*\*)", "HMA Surface (\*)(\*\*)(\*\*\*)" and "HMA Overlay (\*)(\*\*)(\*\*\*)" at the contract unit prices is full compensation for the specified work. Any pay adjustments will both be applied and the payment adjusted accordingly.

Sideroads, entrances and mailbox turnouts that are not shown in the Contract Documents that are to be surfaced shall be paid for at 1½ times the unit price for "HMA Surface (\*)(\*\*)(\*\*\*)" or "HMA Base(\*)(\*\*)(\*\*\*)".

**b. "HMA Pavement" and "HMA Shoulder" Bid Items.** The Engineer will measure HMA Pavement and HMA Pavement Shoulder by the square yard of the measured in-place material. All lifts, except the surface course, will be measured by the Contractor and verified by the Engineer. The Engineer will measure the surface course.

Measure each shoulder width, each driving lane width and subplot length separately. Measure the lengths (to the nearest 0.1 inch) a minimum of once per subplot. The location of the width measurements will be the same location as the mainline cores which were established using random numbers. Before the end of the next working day, type and submit to the Engineer, the Contractor's individual measurements and the sum of the 2 driving lanes. Likewise, when the surface course is completed the Engineer will provide a typed copy of the surface course measurements to the Contractor before the end of the next working day.

If the driving lane and shoulder (measured from centerline) is less than 0.25 feet (per side) deficient, a deduction will be assessed. If the roadway is greater than 0.25 feet (per side) deficient, correction will be required. The correction will be proposed by the Contractor and must be approved by the Engineer. After satisfactory correction by the Contractor, the deduction for the narrow roadway will be eliminated for the areas corrected.

The Engineer will measure the subplot length and width (to the nearest 0.01 feet). Measure the width from the construction joint to the top of the slope of HMA pavement. Calculate the pay area for each lot to the nearest square yard. Unless the Engineer authorizes in writing to increase the area of HMA pavement, the Engineer will use dimensions shown in the Contract Documents and as measured in the field to calculate the final pay quantity. If the Engineer authorizes in writing to increase the area of HMA pavement or shoulder, the additional area will be measured and paid for as "HMA Pavement (#) (##)" or "HMA Pavement (#) Shoulder", respectively. The length will be measured horizontally along the centerline of each roadway or ramp.

Payment for "HMA Pavement (#) (##)" and "HMA Pavement (#) Shoulder" at the contract unit prices is full compensation for the specified work.

The Asphalt Pavement Thickness Adjustment and Asphalt Pavement Area Pay Adjustment will be entered on the Contractor's Payment Vouchers (intermediates and final) after each lot of the surface course (driving lanes and shoulders) has been completed.

The Contractor will receive no additional compensation for overlaying or for removing and replacing areas of deficient thickness. Exploratory cores and cores taken to determine pavement thickness will not be measured for payment. The Engineer will apply a Contract Deduct for surface course (driving lanes and shoulders) and top base course (driving lanes and shoulders) mix not placed on the project as determined using Equation 14. The Contract Deduct will be computed by the spreadsheet and be an item added to the contract.

If the project has a large amount of grinding required for pavement smoothness, the Engineer may require the Contractor to cut cores after the grinding is complete. These cores will be used in the spreadsheet in place of the cores originally cut.

**c. Emulsified Asphalt.** The Engineer will measure emulsified asphalt used for tack by the ton. Payment for "Emulsified Asphalt" at the contract unit price is full compensation for the specified work.

**d. Asphalt Core (Set Price).** The Engineer will measure each asphalt core required by the Engineer to calibrate the nuclear density gauges (typically 3 cores for each calibration). No payment will be made for cores deemed unsuitable for calibrating the nuclear density gauges. No payment will be made for cores taken at the Contractor's option to determine density.

If during nuclear density dispute resolution, the Contractor's test results are used for payment, each core taken will be measured for payment at 1 ½ times the Asphalt Core (Set Price). If KDOT's test results are used for payment, then no payment for cores will be made for nuclear density dispute resolution.

Payment for "Asphalt Core (Set Price)" at the contract set unit price is full compensation for the specified work.

**e. Material for HMA Patching (Set Price).** When the Contractor is required to remove any existing base course, subgrade or surface course (unless damaged by the Contractor) and provisions are not made in the Contract

**602 - HOT MIX ASPHALT (HMA) CONSTRUCTION**  
**(Quality Control/Quality Assurance (QC/QA))**

Documents, the Engineer will measure the material used for repair and patching (either HMA-Commercial Grade or a specified mix on the project) separately, by the ton at the time of delivery to the road. The Engineer will not measure the quantity of material used in the repair of damage due to the Contractor's negligence. The Engineer will measure HMA materials by the ton. For mixes containing Reclaimed HMA Pavement (RAP) or Recycled Asphalt Shingles (RAS), compute the HMA material contained in the RAP and RAS using the binder content determined from ignition oven testing. Maintain this information for materials tracking purposes. No separate payment for HMA material in RAP and RAS will be made. Combined gradation results will be used for acceptance in accordance with **TABLE 602-1**.

Payment for "Material for HMA Patching (Set Price)" at the contract set unit price includes all excavation, compaction of subgrade or subbase if required, disposal of waste material and all material (including emulsified asphalt for tack), all labor, equipment, tools, supplies, incidentals and mobilization necessary to complete the work. Pay adjustments will not be applied to this material.

**f. Quality Control Testing (HMA).** The Engineer will measure Quality Control Testing (HMA) performed by the Contractor on a per ton basis of HMA Surface, HMA Base, HMA Overlay and HMA Pavement placed on the project. No adjustment in the bid price will be made for overruns or underruns in the contract quantity. The bid price will constitute payment for all necessary mix design testing, field process control testing, the testing laboratory and all necessary test equipment.

The Engineer will not measure for payment Quality Control Testing (HMA) for the bid item Material for HMA Patching (Set Price).

Payment for "Quality Control Testing (HMA)" at the contract unit price is full compensation for the specified work.

## 603 - ASPHALT PAVEMENT SMOOTHNESS

### SECTION 603

#### ASPHALT PAVEMENT SMOOTHNESS

##### 603.1 DESCRIPTION

Determine the smoothness of the pavement surface and correct the deficiencies as specified in the Contract Documents.

For the purposes of this specification, define new construction to mean construction where pavement did not exist before, and where existing pavement is removed down to the base and subgrade.

All other conditions should be considered rehabilitation construction.

When projects contain both new and rehabilitation construction, follow appropriate guidelines for each type.

##### BID ITEM

Asphalt Pavement Smoothness

##### UNITS

Lump Sum

##### 603.2 MATERIALS - None specified.

##### 603.3 CONSTRUCTION REQUIREMENTS

**a. Profilograph Testing.** Determine the pavement smoothness by profiling the pavement surface of through traffic lanes and ramps. Excluded from profilograph testing, and not eligible for pay adjustments, on all projects are:

- bridge decks
- acceleration and deceleration lanes of at-grade intersections
- turning lanes
- shoulders
- pavement on horizontal curves with centerline radius of curvature of less than 1000 feet, and pavement within the superelevation transition of such curves
- individual sections of pavement less than 50 feet in length
- the first (or last) 15 feet of a pavement section where the Contractor is not responsible for the adjoining surface
- side roads less than 250 feet in length
- county secondary projects
- existing roadways that are surfaced with a plan thickness of less than 4 inches of either hot mix asphalt (HMA) or warm mix asphalt (WMA)
- chip seals
- microsurfacing

Profile and correct, if necessary, the following categories of asphalt surfacing. These are not eligible for pay adjustments:

- existing roadways that are milled, then surfaced with a plan thickness of less than 4 inches of either hot mix asphalt (HMA) or warm mix asphalt (WMA).
- existing roadways that are surfaced with a plan thickness of less than 4 inches of either HMA or WMA that is placed in 2 or more lifts.
- existing roadways that are cold in-place recycled (CIR) with a plan depth of 2 inches or more, then surfaced with either Ultrathin Bonded Asphalt Surface (UBAS) or a plan thickness of less than 4 inches of either HMA or WMA.
- existing roadways that are hot-in-place recycled (HIR) with a plan depth of 2 inches or more, then surfaced with either UBAS or a plan thickness of less than 4 inches of either HMA or WMA.

In addition to the asphalt surfacing above, profile and correct, if necessary, the following categories of asphalt base, prior to placement of the surface course. These are not eligible for pay adjustments:

## 603 - ASPHALT PAVEMENT SMOOTHNESS

- CIR pavement with a plan thickness of 2 inches or more.
- HIR pavement with a plan thickness of 2 inches or more.

**b. Equipment.** Use a California type profilograph, prequalified by the Bureau of Construction and Materials, to determine the pavement profile. If approved by the Bureau of Construction and Materials, other types of profilographs that produce results compatible to the California type profilograph may be used. If the profilograph has a mechanical recorder, provide a ProScan electronic scanner with motorized paper transport to reduce the trace. Use the motorized paper transport when scanning the profilograph traces. The Bureau of Construction and Materials can provide the information necessary for the Contractor to obtain a ProScan electronic scanner. If approved by the Bureau of Construction and Materials, other types of automated trace reduction equipment may be used. If the profilograph has a computerized recorder, the trace produced is evaluated without further reduction.

**c. Profilograph Operation.** Provide an operator for the profilograph certified according to KT-46, Part V. Determine the pavement profiles for each lane according to the procedures for 1 lane shown in Kansas Test Method KT-46. Additional profiles may be taken only to define the limits of an out-of-tolerance surface variation. The Engineer may use a 10-foot straightedge (or other means) to detect irregularities outside the required trace paths. The Engineer may also use the straightedge to delineate the areas that require corrective action.

Determine a profile index (in./mi.) for each pavement section of finished pavement. A pavement section is a continuous area of pavement surface 0.1 mile long by 1 lane wide (12 feet nominal). A partial pavement section resulting from an interruption (such as a bridge) of the continuous pavement surface is subject to the same testing and evaluation as a whole section.

For projects with asphalt smoothness pay adjustments, profile the pavement after final rolling, and within 24 hours of placement of the pavement.

For projects with no asphalt smoothness pay adjustments, profile the pavement after final rolling, and within 72 hours of completing the asphalt paving on the project. At the engineer's discretion, the Contractor will profile the pavement after final rolling, and within 24 hours of placement of the pavement.

If the Contractor elects to test intermediate lifts with the profilograph, make the profilograms available to the Engineer to review for evaluating the paving methods and equipment.

On surfaces excluded from profilograph testing, the Engineer will determine the pavement smoothness using a 10-foot straightedge. The Engineer will select the locations to be tested. The variation of the surface from the testing edge of the straightedge shall not exceed  $\frac{1}{8}$  inch between any 2 contacts, longitudinal or transverse.

Correct all irregularities exceeding the specified tolerance using equipment and methods approved by the Engineer. After the irregularities are corrected, the Engineer will retest the area to verify compliance with the specified tolerance.

**d. Profilograph Evaluation and Corrective Actions.** Evaluate the profilograph results according to KT-46. For projects with asphalt smoothness pay adjustments, provide the Engineer with the profilograms and their evaluation the first working day after placement of the pavement. For projects with no asphalt smoothness pay adjustments, provide the Engineer with the profilograms and their evaluation the first working day after profiling the roadway.

Determine and evaluate the profile index (in./mi.) for each trace and the average profile index (in./mi.) for each section to identify where corrective action is needed.

Determine the daily average profile index (in./mi.) for each day's paving operation. A day's paving operation is the pavement placed in a day (a minimum of 1 pavement section).

- If less than 1 pavement section is placed in a day, the day's production is grouped with the next day's production.
- If the production of the last day of project paving is less than 1 pavement section, it is grouped with the previous day's production.
- The Contractor has the option of profiling the final portion of a day's production (not to exceed 5 sections) the first working day that paving is continued in the same lane. If the Contractor opts to profilograph the final portion of a day's paving the next working day that paving is continued in the same lane, those results (the final portion of the previous day's paving) are grouped with the day's paving as the lane is continued.

(1) For new construction bid items in **SECTION 602**, take the required corrective actions according to **TABLE 603-1**.

**603 - ASPHALT PAVEMENT SMOOTHNESS**

<b>TABLE 603-1: ASPHALT PAVEMENT SURFACE TOLERANCES, NEW CONSTRUCTION SECTION 602 BID ITEMS</b>		
<b>Pavement Surface Tolerances (in./mi.)</b>		<b>Required Corrective Action</b>
<b>Through Lanes Speed Limit Greater than 45 mph</b>	<b>Acceleration Lanes* Deceleration Lanes* Ramps* Through Lanes Speed Limit 45 mph or Less</b>	
Profile Index per Section of 30 or less for an individual trace	Profile Index per Section of 40 or less for an individual trace	Correct all bumps and dips**.
Profile Index per Section greater than 30 for an individual trace		Correct the Profile Index of each individual trace to 30 or less per section**.
	Profile Index per Section greater than 40 for an individual trace.	Correct the Profile Index of each individual trace to 40 or less per section**.
Daily Average Profile Index greater than 40	Daily Average Profile Index greater than 65	Suspend the paving operations until corrective actions are taken to improve the paving operations.

\*Acceleration/deceleration lanes include the taper. Acceleration lanes that become through lanes are limited to 500 feet from the nose of the ramp. Ramps are from the nose to the intersection of the adjoining road.

\*\*Correct all areas within each section having high or low points (bumps or dips) with deviations in excess of 0.3 inches in a length of 25 feet or less regardless of the profile index value.

(2) For all other rehabilitation construction bid items in **DIVISION 600**, take the required corrective actions according to **TABLE 603-2**.

<b>TABLE 603-2: ASPHALT PAVEMENT SURFACE TOLERANCES, REHABILITATION DIVISION 600 BID ITEMS (EXCEPT SECTION 602, NEW CONSTRUCTION)</b>		
<b>Pavement Surface Tolerances (in./mi.)</b>		<b>Required Corrective Action</b>
<b>Through Lanes</b>	<b>Acceleration Lanes* Deceleration Lanes* Ramps* 2" Surface Recycled Asphalt/Hot In-place Recycled Asphalt Pavement Cold Recycle Asphalt Construction</b>	
Profile Index per Section of 30 or less for an individual trace	Profile Index per Section of 40 or less for an individual trace	Correct all bumps and dips**.
Profile Index per Section greater than 30 for an individual trace		Correct the Profile Index of each individual trace to 30 or less per section**.
	Profile Index per Section greater than 40 for an individual trace.	Correct the Profile Index of each individual trace to 40 or less per section**.
Profile Index per Section greater than 40 for an individual trace	Profile Index per Section greater than 50 for an individual trace.	Suspend the paving operations until corrective actions are taken to improve the paving operations.

\*Acceleration/deceleration lanes include the taper. Acceleration lanes that become through lanes are limited to 500 feet from the nose of the ramp. Ramps are from the nose to the intersection of the adjoining road.

\*\*Correct all areas within each section having high or low points (bumps or dips) with deviations in excess of 0.4 inches in a length of 25 feet or less regardless of the profile index value.

## 603 - ASPHALT PAVEMENT SMOOTHNESS

**f. Corrections.** Make the required corrections for pavement smoothness before making the pavement thickness determinations. Use these methods for corrections:

- diamond grinding when the layer is the final riding surface
- when the layer will be covered with an asphalt seal or microsurfacing
  - micro-milling or fine-lace milling (minimum of 60 teeth per foot) may be done in a continuous 100-foot segment provided there is at least 400 feet of the surface adjacent to the segment that is not milled or diamond ground
  - diamond grind when more than 100 feet within a 400-foot segment requires correction. The Engineer may permit micro-milling if in the opinion of the Engineer the resulting surface is not detrimental to the functionality of the asphalt seal or the microsurfacing
- milling if the layer will be covered by another action
- remove and replace the entire pavement thickness
- remove the surface by milling, and replace the specified surface course
- overlay (not patch) with the specified surface course
- other methods that are approved by the Engineer

Apply the corrective measure to the full-lane width of the pavement. The corrected areas shall have uniform texture and appearance. The beginning and ending of the corrected areas shall be squared normal to centerline of the paved surface.

When grinding is performed, use vacuum equipment or other continuous methods to remove grinding slurry and residue. Remove from the project and properly dispose of the material. Do not allow the grinding slurry to flow across lanes being used by traffic, onto shoulder slopes, into streams, lakes, ponds or other bodies of water, or gutters or other drainage facilities. Do not place grinding slurry on foreslopes.

**g. New Construction Bid Items in SECTION 602, and Eligible for Pay Adjustments.** After the profilograph traces have been evaluated, make corrections according to **TABLE 603-3**.

<b>TABLE 603-3: GRINDING REQUIREMENTS</b>	
<b>Condition</b>	<b>Action*</b>
Greater than 25% (132 feet) of the 0.1 mi. section requires correction	Continuously grind the entire 0.1 mi. section.**
Greater than 25% (1320 feet) of 1.0 mi. segment require correction	Continuously grind the entire 1.0 mi. segment, when the areas requiring correction are dispersed throughout the 1.0 mi. segment. If the areas requiring correction are isolated to 1/3 or 1/2 mi. within the 1.0 mi. segment, then only grind that 1/3 or 1/2 mi.

\* Continuously grinding requires a minimum of 98% of the pavement be ground.

\*\*If the skip length between areas to be ground (either within a 0.1 mi. section or between 0.1 mi. sections) is less than either grind length, combine the grinds so the area between is also ground. This additional ground area (area between) will apply to the computation of the 25% of the 0.1 mi. section.

If the Contractor elects or is required by **TABLE 603-3** to continuously grind the entire project, the following apply:

- the areas excluded in **subsection 603.3a**. are not required to be ground;
- at intersections constructed with multiple transitions for drainage (especially in urban areas), if smoothness meets **SECTION 603**, the intersection is not required to be ground; and
- when transitioning from a ground area to an unground area, feather the grinding a uniform distance throughout the project.

Grind and texture the entire surface of the pavement in the longitudinal direction. Provide positive lateral drainage by maintaining a constant cross slope between grinding passes in each lane.

Maintain a uniform transverse slope that matches the existing cross slope to the extent possible with no depressions or humps greater than 1/4 inch in 12 feet when tested with a string line or straightedge. Do not exceed by more than 1/16 inch the vertical alignment between adjacent passes of the cutting head. Begin and end grinding lines normal to the direction of vehicle travel. Grind the surface so corrugations are parallel to the pavement edge with ridges 1/16 inch, ±1/32 inch higher than the valleys of the corrugations.

**603 - ASPHALT PAVEMENT SMOOTHNESS**

**g. Profilograms.** After pavement sections are corrected, re-profile the pavement surface to verify compliance with the specified pavement smoothness. Provide the Engineer with the profilograms and their evaluation within 2 working days after correcting the pavement surface.

The Engineer may perform profilograph testing on the pavement surface for monitoring and comparison purposes. If the Engineer determines that the Contractor’s certified test results are inaccurate, the Engineer may choose to test the entire project length. The Engineer will charge the Contractor for such testing at the rate of \$500 per mile per profile track, with a minimum charge of \$1000. Providing inaccurate test results may result in de-certification of the Contractor’s certified operator.

**603.4 MEASUREMENT AND PAYMENT**

**a. General.** The Engineer will base the pay adjustment for pavement smoothness on the initial average profile index of the pavement section before any corrective work is performed. If the Contractor elects to remove and replace a pavement section, the Engineer will base the pay adjustment for pavement smoothness on the initial average profile index of the pavement section after the replacement.

For reconstruction projects, if the Contractor elects or is required by **TABLE 603-3** to continuously grind the entire project, pay adjustments will be based on the average profile index determined after all grinding is performed.

**b. New Construction, Bid Items in SECTION 602, Eligible for Pay Adjustments.** The Engineer will apply the contract price adjustment according to **TABLE 603-4**. Payments for "Asphalt Pavement Smoothness" are an added item to the contract.

<b>TABLE 603-4: ASPHALT PAVEMENT SMOOTHNESS PAY ADJUSTMENT NEW CONSTRUCTION</b>	
<b>Average Profile Index (in./mi. per lane per 0.1 mi. section)</b>	<b>Contract Price Adjustment (per 0.1 mi. section per lane)</b>
6.0 or less	+\$1000.00
6.0 to 10.0	+\$835.00
10.1 to 15.0	+\$625.00
15.1 to 18.0	+\$310.00
18.1 to 30.0	0.00
30.1 to 40.0	0.00*
40.1 or more	-\$615.00*

\*Correct to 30.0 in./mi. (40.0 in./mi. as noted in **TABLE 603-1**).

The pay adjustments in **TABLE 603-4** are for 12" thick hot mix asphalt and 8" thick portland cement concrete pavements. Pay adjustments for pavements of different thicknesses will be reduced or increased proportionally, based on the typical section for the extent. (i.e. pay adjustment for a 9" hot mix asphalt pavement is equal to the adjustment from the **TABLE 603-4** multiplied by 0.75).

**c. Rehabilitation Construction, for all Other Bid Items in DIVISION 600 and Eligible for Pay Adjustments, Take the Required Corrective Actions According to TABLE 603-5.** The Engineer will apply the contract price adjustment according to **TABLE 603-5**. Payments for "Asphalt Pavement Smoothness" are an added item to the contract.

<b>TABLE 603-5 ASPHALT PAVEMENT SMOOTHNESS PAY ADJUSTMENT REHABILITATION CONSTRUCTION</b>	
<b>Average Profile Index (in./mi. per lane per 0.1 mi. section)</b>	<b>Contract Price Adjustment (per 0.1 mi. section per lane)</b>
7.0 or less	+\$152.00
7.1 to 10.0	+\$76.00
10.1 to 30.0	0.00
30.1 to 40.0	0.00*
40.1 or more	-\$203.00*

\*Correct to 30.0 in./mi. (40.0 in./mi. as noted in **TABLE 603-1**).

**604 - COLD RECYCLED ASPHALT CONSTRUCTION (CIR)**

**SECTION 604**

**COLD RECYCLED ASPHALT CONSTRUCTION (CIR)**

**604.1 DESCRIPTION**

Mill the asphalt pavement, mix the reclaimed asphalt pavement (RAP) material with hydrated lime slurry (use a minimum of 1% hydrated lime, based on the dry weight of the RAP) and emulsified asphalt, and spread and compact the mixture as specified in the Contract Documents.

<u><b>BID ITEMS</b></u>	<u><b>UNITS</b></u>
Cold Recycled Asphalt Material	Station
Lime (Hydrated) (Slurry)	Ton
Emulsified Asphalt (CSS) (Special)	Ton
Emulsified Asphalt (CSS-1H or SS-1H) Cure (Set Price)	Ton
Blotter Sand (Set Price)	Cubic Yard

**604.2 MATERIALS**

Provide materials that comply with the applicable requirements.

Emulsified Asphalt .....	<b>DIVISION 1200</b>
Lime .....	<b>DIVISION 2000</b>
Water .....	<b>DIVISION 2400</b>

Blotter sand may be any fine sand approved by the Engineer.  
Provide processed RAP material that complies with **TABLE 604-1**.

<b>TABLE 604-1: RAP MATERIAL FOR CIR</b>	
<b>Sieve Size</b>	<b>% Retained</b>
1 1/4"	0

Manufacture the hydrated lime slurry at the jobsite by slaking pebble quicklime. Accompany each load of quicklime with a certification stating the purity for that load.

**604.3 CONSTRUCTION REQUIREMENTS**

**a. Mix Design.** Submit to the Engineer for approval a mix design complying with 5.3.4-Mix Design Procedures for CIR Material, Part V.

Provide a technical representative from the asphalt emulsion supplier on the job site at the beginning of the CIR to obtain proper asphalt emulsion performance. When required, provide a technical representative to check on the project and make adjustments to the asphalt emulsion formulation as needed.

**b. Milling Operation.** Mill the required depth and width in 1 or more passes. Process the RAP material to the required gradation and thoroughly mix with the specified amount of binder. Water may be added to the RAP material to facilitate mixing, provided it does not adversely affect the binder. Deposit the recycled material in a windrow, a paver or load into trucks, without segregation.

When deposited in a windrow, have equipment available to equalize the windrow as directed by the Engineer.

If RAP is to become the property of the Owner, deliver and stockpile at locations shown in the Contract Documents.



## 604 - COLD RECYCLED ASPHALT CONSTRUCTION (CIR)

### c. Mixing Operations.

(1) Field Mixture Testing. Take all samples according to KT-1(3.1) or (3.2). Obtain a sample from each 0.6 mile before emulsion addition, and screened using a 1¼-inch sieve (or smaller sieve if required) to determine compliance with the maximum particle size requirement.

Additionally, obtain 2 gradations each day and compare to the mix design gradations using KT-4 to determine any necessary changes to the emulsion content.

(2) Asphalt Emulsion. Do not accept asphalt emulsion with a temperature greater than 120°F, **TABLE 601-1**. Sample and accept or reject from the shipping trailers prior to unloading into the Contractor's storage units.

(3) Asphalt Emulsion Content. Check and record the emulsion content for each segment in which the percentage is changed. Make emulsion content changes based upon mix design recommendations, which are based upon different mix designs for road segments of varying construction. Determine asphalt emulsion content from the belt scale totalizer and asphalt pump totalizer.

(4) Lime Slurry Content. Add the amount of hydrated lime to the RAP determined by the mix design or directed by the Engineer, based on the weight of the dry RAP.

Add pebble quicklime by weight to the required quantity of water to provide a uniformly hydrated lime slurry having a minimum dry solids content of 30%. When requested by the Engineer, determine the solids content of the hydrated lime according to "Check Percent Solids of Lime Slurry Procedure" (KT-62). Check and record the lime slurry content for each segment in which the percentage is changed. Make the lime slurry changes based upon mix design recommendations or as approved by the Engineer.

(5) Water Content. Verify and record the water content at the milling head for each segment in which the percentage is changed. Determine water quantities from the water metering device, and compare with the belt scale totalizer to determine daily quantities used. Make the water content adjustments based on mixture consistency, coating and dispersion of the recycled materials.

**d. Paving Operations.** Deliver the RAP, lime and/or water and emulsion mixture to the paver immediately after mixing. The minimum temperature of the mixed material when placed is 50°F. Pave in 1 continuous pass, utilizing an asphalt paver complying with **SECTION 155** or other equipment approved by the Engineer. Without tearing the surface, spread and finish the recycled material, to the lines and grades in the Contract Documents or established by the Engineer so it is smooth, free of segregation, uniform in density, texture and free from surface irregularities. Do not heat the paver screed. A pick-up machine may be used to transfer the windrowed material into the paver hopper. Maintain the asphalt paver within 150 feet of the mixing unit. If the process does not comply with these requirements, the Engineer will suspend paving until the deficiency is corrected.

**e. Compaction and Density Requirements.** Compaction and density requirements for each project shall be a minimum of 97% of the target density obtained on a test strip compacted under the following conditions:

- The minimum mix temperature of the test strip is 50°F;
- Complete a minimum of 2 test strips to determine the target density and optimum sequence of rollers. These test strips shall remain in place as part of the completed work; and
- The depth of the lift shall be representative of the requirements of the Contract Documents.

Target density shall be the highest density achieved on the test strip using the rolling procedure approved by the Engineer. The rolling procedure used on the test strip shall have a minimum of 6 roller coverages. The Engineer will use a nuclear density gauge to establish a density growth curve for each procedure. Discontinue rolling when 4 consecutive coverages of the rollers fail to increase the density 1 pound per cubic foot.

As a minimum, provide the following self-propelled rollers for use on the test strips: a double drum vibratory steel roller and a pneumatic tired roller. Provide a vibratory roller complying with the requirements for hot asphalt pavement in **subsection 151.5** and having a minimum operating weight of 10 tons and a minimum drum width of 6½ feet. The vibratory roller may be used in the static mode. Use a pneumatic tired roller with a minimum weight of 30 tons and a minimum tire pressure of 90 psi. The air pressure in each of the pneumatic tires shall be within 5 psi of each other. Supply a suitable tire pressure gauge.

Change rolling or roller patterns when major displacement and/or cracking of the recycled material occur. Start rolling a maximum of 30 minutes after paving. Complete finish rolling a maximum of 1 hour after milling is completed. When possible, begin and end rolling sequences on previously compacted material or the existing pavement.

## 604 - COLD RECYCLED ASPHALT CONSTRUCTION (CIR)

Before and after opening to traffic, maintain the surface of the recycled pavement in a condition suitable for the safe movement of the traffic. Remove all loose particles that develop on the pavement surface by power brooming.

When there is a significant change in mix proportions, weather conditions or other controlling factors, the Engineer may require construction of a new test strip to check target density.

**f. Surface Treatment or Overlay.** When required by the Engineer, apply a light application of asphalt material (smoke coat) on the recycled surface, and blot with fine sand, as necessary.

Before placing a HMA surface course, or other applicable surface treatment, allow the CIR asphalt material to cure until the moisture of the material is a maximum of 2.0%, or approved by the Engineer. Under dry conditions, the CIR should comply with the moisture requirements within 48 hours.

Cover each day's production of CIR material with any subsequent treatment or overlay, as designated in the Contract Documents, within 21 calendar days. If the CIR material requires patching before the 21 days have expired, and damage is not the result of the Contractor's operations, KDOT will pay for the patching. If the Contractor has not covered the CIR material by the end of the 21-day period and the material requires patching, the Contractor shall be responsible for the patching. Begin patching within 3 days of being notified by the Engineer of required patching.

**g. Maintenance of Traffic.** Perform traffic control according to **DIVISION 800**.

**h. Weather and Seasonal Limitations.** Complete milling, adding the liquid binder and laydown between May 1 and September 30, when the ambient air temperature is greater than 50°F and rising, the weather is not rainy or foggy and the weather forecast does not call for freezing temperature within 48 hours after placement. The above requirement may be waived, when approved in writing by the Engineer.

**i. Pavement Smoothness.** Evaluate pavement smoothness according to **SECTION 603**.

### 604.4 MEASUREMENT AND PAYMENT

The Engineer will measure cold recycled asphalt material by the Station, along the centerline. On divided highways, the Engineer will measure cold recycled asphalt material by the Station, along the centerline of each divided direction. This includes all widened and irregular areas and irregular variations in depth.

The Engineer will measure lime (hydrated) (slurry) and the various types of emulsified asphalt by the ton.

The Engineer will measure blotter sand by the cubic yard in the truck at the point of usage.

The Engineer will not measure water for separate payment.

Payment for "Cold Recycled Asphalt Material", "Lime (Hydrated) (Slurry)" and "Emulsified Asphalt (CSS (Special))" at the contract unit prices and "Blotter Sand (Set Price)" and "Emulsified Asphalt (CSS-1H or SS-1H) Cure (Set Price)" at the contract set unit prices is full compensation for the specified work.

**605 - SURFACE RECYCLED ASPHALT CONSTRUCTION**

**SECTION 605**

**SURFACE RECYCLED ASPHALT CONSTRUCTION**

**605.1 DESCRIPTION**

Construct the hot-in-place recycling of the existing asphalt surface as specified in the Contract Documents. The activities associated with this work include heating the existing pavement, scarifying and/or hot milling the existing surface, adding a rejuvenating agent, mixing, spreading, leveling and compacting the recycled material. This process is referred to as Hot In-Place Recycled Asphalt Pavement (HIR). The term surface recycling and HIR are synonymous in the specification.

**BID ITEMS**

Surface Recycling (\*)  
Asphalt Rejuvenating Agent  
\*Thickness

**UNITS**

Station  
Ton

**605.2 MATERIALS**

**a. Asphalt Rejuvenating Agent (ARA).** Provide ARA that complies with **DIVISION 1200**.

**b. Contractor Mix Design.** When the specified thickness of the HIR is greater than or equal to 2 inches, submit a mix design complying with **TABLE 605-1**.

In the mix design, analyze the mixture at a minimum of 3 different ARA contents starting with 0.5% at the low end. Run the indirect tensile strength test (KT-60) at the lowest ARA content. Run the Asphalt Pavement Analyzer (AASHTO T 340) at the highest ARA content.

<b>TABLE 605-1: SURFACE RECYCLE MIX DESIGN REQUIREMENTS</b>		
<b>Property</b>	<b>Test Method</b>	<b>Limits</b>
Air Voids at 30 gyrations, (%)	KT-58, KT-15, & KT-39	Report
Tensile Strength, (psi min)	KT-56	75
Retained Strength based on cured stability, (% min)	KT-56	80
Rut Resistance, (mm max)	AASHTO T 340	8
Thermal Cracking, (°C max)	KT-60	-22

Testing procedures:

- Core the pavement to obtain Reclaimed Asphalt Pavement (RAP) for the mix design.
- Break down the RAP (representing the depth of the HIR) to a maximum particle size of 1 inch.
- The compaction temperature range for KT-58 is 200°F to 250°F.
- Perform all tests on plugs that are compacted to 30 gyrations, thus the air void criteria stated in KT-56, KT-60 and AASHTO T 340 are waived.
- Use procedure III when performing KT-15.

**605.3 CONSTRUCTION REQUIREMENTS**

**a. Pavement Preparation.** Before commencing surface recycling, remove all material from the surface of the pavement which would be detrimental to the HIR or would not comply with the design criteria of **subsection 605.2b**.

**b. Heating and Scarifying Operations.** Use a series of heaters, milling units and/or scarifiers to uniformly heat and recycle the existing pavement to the specified depth. Flames on the pavement can be prevented by heating the roadway more slowly using additional heaters. Intermittent or occasional flaming on the roadway or in the windrow that extinguishes on its own within 10 seconds is permissible, but if in the opinion of the Engineer it is detrimental to the final product, production will cease. In addition, production will cease when smoke is being produced continuously. (Smoke caused when the heaters pass over a maintenance patch is excluded from this

## 605 - SURFACE RECYCLED ASPHALT CONSTRUCTION

clause.) The Contractor and Engineer will agree to a course of action to prevent this overheating before production is resumed. If flames or excessive smoke persists, then production is ceased until the Contractor modifies the operation and can demonstrate acceptable results without excessive smoke or flames on the pavement or in the windrows. When the depth of the HIR is more than 1 inch, heat the material in lifts not more than ¾ inches. When heating in multiple lifts, remove each lift at a uniform depth across the full width of the recycled pavement. This material may be windrowed when heating the next lift. Use equipment complying with **SECTION 155**. Provide adequate provisions for equipment calibration. Remove from the roadway milled or scarified material that can not be placed with a paving unit due to equipment breakdown or malfunction. Bring these removed areas to grade using a HMA approved by the Engineer.

### c. Process Control.

(1) Depth Check. The Engineer will determine the depth per KT-47. The moving average of 3 consecutive tests shall equal or exceed the contract depth. If the 3-point moving average is less than the contract depth, KDOT will assess a Surface Recycling Pay Adjustment using Equation 1. The pay adjustment will correspond to those segments within the 3-point moving average that were deficient in depth.

$$\text{Equation 1: } P = 400 (S) \left( 1 - \frac{M}{T} \right)$$

Where: P is the Surface Recycling Pay Adjustment, (\$0.00)

S is the number of stations (single lane) in penalty, (0.00)

M is the Measured Depth 3-point moving average, (0.000 feet or 0.00 inches)

T is the Plan Depth, (0.000 feet or 0.00 inches). T and M shall be the same unit of measure.

If 4 consecutive 3-point moving average values are less than the contract depth, stop production and evaluate the process with the Engineer. Change the process to the satisfaction of the Engineer before production is resumed. If the next 2 tests are deficient in thickness, Equation 2 will be used for the remainder of the project. The Engineer reserves the option to terminate production until a satisfactory agreement is reached anytime the 3-point moving average value is less than the contract depth for more than 2 consecutive tests.

$$\text{Equation 2: } P = 900 (S) \left( 1 - \frac{M}{T} \right)$$

If both KDOT and the Contractor agree that recycling to the contract depth would be detrimental to the project, the unit price will be negotiated for the reduced depth before proceeding with the project, and the Engineer would create a change order (**SECTION 104**) for the item at the new unit price.

(2) Temperature Requirements: Heat the HMA being scarified and/or hot milled to a minimum of 190°F prior to scarifying and/or hot milling. Maintain the temperature of the HIR, directly behind the paver, between 190°F and 300°F. HIR temperatures taken within 2 feet of each other, transverse to the roadway, shall not vary by more than 30°F. HIR temperatures taken within 10 feet of each other, transverse to the roadway, shall not vary by more than 50°F. If these temperature requirements are not satisfied within 1 hour after a discrepancy is discovered, the HIR train will be stopped and the Engineer and Contractor will determine a course of action to correct the deficiency before the HIR train proceeds.

**d. Rejuvenating and Mixing Operations.** After heating and scarifying and/or hot milling, uniformly add the ARA and thoroughly mix the HIR. Include all of the previously scarified and/or hot milled material into the mixing operation.

**e. Spreading and Compacting Operations.** Immediately following heating, scarifying, adding ARA and mixing operations, begin work to fulfill the requirements of one of the following operations:

(1) Operation Number 1.

(a) Spread and finish the rejuvenated mixture with an acceptable paving unit.

(b) Provide density using an approved rolling procedure. Use a minimum of 2 Self-Propelled Smooth-Faced Steel Rollers complying with **SECTION 151**. The Engineer will determine the initial approved rolling procedure from densities obtained with various roller combinations.

## 605 - SURFACE RECYCLED ASPHALT CONSTRUCTION

Density will be determined by using a nuclear gauge. Use the approved rolling procedure. Achieve the maximum density before the temperature of the HIR falls below 160°F. Do not crush the aggregate. When the mat temperature falls below 160°F, roller marks may be removed from the mat with a self-propelled Smooth-Faced Steel Roller operated in the static mode. If there is a significant change in factors affecting density, such as weather or compaction equipment, the Engineer will reevaluate and modify the rolling procedure as required. Stop the HIR operation whenever rolling is not being performed according to the approved rolling procedure.

(c) Maintain the rejuvenated pavement surface until the surface treatment shown in the Contract Documents is completed. When required, apply a tack coat before placing the surface treatment. If a seal coat, asphalt seal, micro-surfacing or ultra-thin bonded asphalt surface is included in the Contract Documents, allow the HIR surface to cure 1 week before sealing.

(2) Operation Number 2. Use an asphalt paver equipped with automatic grade control to spread and finish the amount specified of the new asphalt surface material. **SECTIONS 601** and **602** apply. If a HMA overlay is included in the contract, place the HMA and surface recycle concurrently, or the 2 materials may be blended and laid as 1 lift.

**f. Weather and Seasonal Limitations.** Construct surface recycling when the surface is dry, and the weather is not foggy or rainy. Only construct surface recycling between May 1 and September 30, when either the minimum ambient air temperature or the road surface temperature shown in **TABLE 605-2** is met.

<b>Existing Surface Type</b>	<b>Ambient Air Temperature (°F)</b>	<b>Road Surface Temperature (°F)</b>
On HMA Surface	50	55
On Asphalt Seal Surface	55	60

**g. Pavement Smoothness.** Evaluate pavement smoothness according to **SECTION 603**.

### 605.4 MEASUREMENT AND PAYMENT

The Engineer will measure surface recycling by the Station, along the centerline. On divided highways, the Engineer will measure surface recycling by the Station, along the centerline of each divided direction. This includes all widened and irregular areas and irregular variations in depth.

The Engineer will measure asphalt rejuvenating agent by the ton.

Payment for "Surface Recycling" and "Asphalt Rejuvenating Agent" at the contract unit prices is full compensation for the specified work.

The bid item Surface Recycling Pay Adjustment will be an item added to the contract.

**606 - MICROSURFACING**

**SECTION 606**

**MICROSURFACING**

**606.1 DESCRIPTION**

Spread a mixture of modified emulsified asphalt, mineral aggregate, water and additives on a prepared surface as specified in the Contract Documents.

<u><b>BID ITEMS</b></u>	<u><b>UNITS</b></u>
Aggregate for Microsurfacing	Ton
Emulsified Asphalt (*) (Modified)	Ton
Mineral Filler	Ton
*Designated Type and Grade	

**606.2 MATERIALS**

Provide materials that comply with the applicable requirements.

Emulsified Asphalt .....	<b>DIVISION 1200</b>
Aggregate for Microsurfacing .....	<b>DIVISION 1100</b>
Water .....	<b>DIVISION 2400</b>

Conduct aggregate acceptance tests at the point of usage.

Use a Cationic Type CSS-1HM emulsified asphalt complying with **SECTION 1202**.

For mineral filler, use any recognized brand of non-air-entrained portland cement that is free of lumps and acceptable to the Engineer.

Provide a Type "C" certification for any proposed additives.

The Engineer will test materials according to the Contract Documents and Appendix B-Sampling and Testing Frequency Chart-Quality Control/Quality Assurance Specifications.

**606.3 CONSTRUCTION REQUIREMENTS**

**a. Mix Design.**

(1) Job Mix Formula. Develop and submit the job mix formula and certified test results meeting the criteria in **TABLE 606-1** for the Engineer's approval. Include aggregate type and gradation, percentage of modified emulsion, water and cement by weight of dry aggregate in the mix.

<b>TABLE 606-1: MICROSURFACING MIX DESIGN REQUIREMENTS</b>		
<b>Property</b>	<b>Test</b>	<b>Requirements</b>
Wear Loss (Wet Track Test)	ASTM D6372 (1 hr soak) (6 day soak)	50 g/ft <sup>2</sup> , maximum 75 g/ft <sup>2</sup> , maximum
Wet Cohesion	ASTM D6372 @ 30 minutes @ 60 minutes	10 in-lbs, minimum 17 in-lbs, minimum
Wet Stripping	ISSA TB-114	90%, minimum
Mix Time @ 77°F	ISSA TB-113	Controllable to 120 seconds, minimum

(2) Proportioning. Use the proportions in **TABLE 606-2** unless otherwise shown in the Contract Documents. Do not begin microsurfacing until the Engineer approves the mix design, materials, and construction.

## 606 - MICROSURFACING

<b>TABLE 606-2: MICROSURFACING MIX PROPORTIONING</b>		
Material	Units	Value
Mineral Aggregate	lbs/SY dry weight	15, minimum
Modified Emulsion	Percent residue by weight	6.5, minimum
Mineral Filler	Percent by weight of dry aggregate	1.0 to 3.0 *
Additive	Percent by weight of dry aggregate	As required

\* Unless otherwise approved by the Engineer.

(3) Aggregate and Asphalt. Screen the aggregate for lumps, and weigh it before delivery to the lay down machine. Weigh the emulsified asphalt. The Engineer will approve the screens and scales.

Provide individual volume or weight controls for proportioning each item to be added to the mix. Calibrate and mark each material control device. Locate the devices to be accessible for ready calibration, and place so the Engineer can determine the amount of each material used at any time.

Mineral filler may be added at the loading facility, provided the Engineer approves accurate proportioning and metering devices, and there is no detrimental effect on the final product.

**b. Surface Preparation.** Immediately before applying the microsurfacing, thoroughly clean the surface of the roadway of all foreign material and pre-wet as required.

**c. Ruts.** When shown in the Contract Documents, fill ruts, utility cuts and depressions in the existing surface before placing the final surface. Cover ruts and irregularities of less than ½ inch in depth with a full width scratch coat. Accomplish the scratch coat by using a rigid rear seal in the spreading equipment.

Independently fill ruts greater than ½ inch in depth using a rut filling spreader box 5 to 6 feet in width. Crown ruts filled with a rut filling spreader box to compensate for compaction.

Ruts in excess of 1 ½ inches require multiple passes with the spreader box to restore the original cross section. When multiple passes are required, carry traffic overnight on each rut-filling pass before a subsequent filling pass is made.

**d. Mixing and Spreading.** Mix and spread the microsurfacing materials with a self-propelled machine capable of accurately delivering and proportioning all of the required components. Operate the machine continuously while loading, eliminating construction joints. Do not use lumping, balling or unmixed aggregate.

Place longitudinal joints on lane lines. Do not overlap or leave gaps in longitudinal joints. Construct a finished microsurface with a uniform texture and free of scratches, tears and other surface irregularities. Repair the surface if any of these conditions exist:

- more than 1 surface irregularity that is ¼ inch or wider and 10 feet or longer in any 100 foot section of the microsurface;
- more than 3 surface irregularities that are ½ inch or wider and more than 6 inches long in any 100 foot section of the microsurface; or
- any surface irregularity that is 1 inch or wider and more than 4 inches long.

Construct finished, uniform, longitudinal and transverse joints in the microsurface. Repair the joints if any of these conditions exist:

- build-up of microsurface material at the joints;
- uncovered areas at the joints;
- longitudinal joints with more than ½ inch vertical space between the surface and a 4 foot straightedge placed perpendicular to the joint; or
- transverse joints with more than ¼ inch vertical space between the surface and a 4 foot straightedge placed perpendicular to the joint.

Construct the edges of the microsurface to follow the centerline, lane lines, shoulder lines and curb lines. Repair edges that vary more than ± 3 inches from a 100 foot straight line (or a 100 foot arch on a curved section).

Use methods approved by the Engineer to correct deficiencies in the microsurface. Construct a dense, repaired surface with a uniform texture.

## 606 - MICROSURFACING

**e. Curing.** Provide adequate means to protect the microsurface from damage by traffic until the mixture has cured sufficiently. Allow the surface of microsurfacing to cure so as to not adhere to or be picked up by the tires of vehicles. Allow traffic to use the microsurfacing when cured.

Cure the material used for filling wheel ruts a minimum of 24 hours before the full width coverage is applied.

**f. Maintenance of Traffic.** Maintain traffic according to **DIVISION 800** and the following:

- Station 1 flagger immediately ahead of the application of the microsurfacing material and 1 flagger immediately behind the section being cured.
- Display suitable speed limit signs and “fresh oil” signs. Move the signs forward with the flaggers as the work progresses.
- Suspend application of the microsurface early enough each day to permit traffic to safely travel over the completed work before sunset.
- Repair any traffic damage to the microsurface at Contractor expense.

**g. Seasonal and Weather Limitations.** Construct the microsurfacing between May 1 and October 15. Do not place microsurfacing when the ambient air temperature is less than 50°F, or the weather is foggy or raining, and the air temperature is forecasted to go below 32°F within 24 hours following the placement.

**h. Observation Period.** The Engineer, along with the Contractor, will inspect the microsurfacing 30 days after work is completed on the microsurfacing. Repair areas where there is no cover material left in place (bare areas) as directed by the Engineer:

- In 5% the wheel paths; and
- Individual areas  $\geq$  10 square yards; and
- Where the total square yards of bare areas is greater than 5% of the total square yards of the seal.

**g. Pavement Smoothness.** Microsurfacing is excluded from profilograph testing, and not eligible for pay adjustments.

### 606.4 MEASUREMENT AND PAYMENT

The Engineer will measure aggregate for microsurfacing, emulsified asphalt (modified) and mineral filler by the ton. No deduction will be made for moisture in the aggregate. When sacked portland cement is used, 1 sack equals 94 pounds.

Water used for pre-wetting the pavement surface and mix water is subsidiary to other bid items and will not be measured for separate payment.

Material used to correct surface deficiencies in the microsurfacing will not be measured for payment.

Payment for "Aggregate for Microsurfacing", "Emulsified Asphalt (Modified)" and "Mineral Filler" at the contract unit prices is full compensation for the specified work.



## 607 - ASPHALT PRIME COAT

### SECTION 607

#### ASPHALT PRIME COAT

##### 607.1 DESCRIPTION

Treat a previously prepared surface with asphalt material, and apply blotter material, when required, as specified in the Contract Documents.

##### BID ITEMS

Emulsified Asphalt (\*)

Cutback Asphalt (\*)

\*Designated Type and Grade.

##### UNITS

Ton

Ton

##### 607.2 MATERIALS

Provide asphalt materials that comply with **DIVISION 1200**.

##### 607.3 CONSTRUCTION REQUIREMENTS

**a. Preparation of Road Surfaces.** Before distributing asphalt materials, blade the surface of the roadbed to a smooth, uniform cross-section. Broom off all loose materials, and clean the surface until it is free from dust. Shape, blade and broom side roads that receive asphalt treatment, at the same time as the roadbed surface. When required by the Engineer, give the broomed surface of an earth subgrade or a water-bound base course or subbase a light application of water (approximately 0.1 gallon per square yard) before the asphalt material is applied.

**b. Protection of Adjacent Structures.** Protect the surfaces of all structures and other roadway appurtenances from damage or splatter of asphalt material. Restore any damaged or splattered appurtenances to their original condition at own expense.

**c. Temperature of Asphalt Materials at Time of Application.** Apply asphalt material at the temperature specified in **TABLE 601-1**, or included on the producer's Bill of Lading.

**d. Prime Coat.** Apply the prime coat to earth subgrades, water-bound base courses and subbases as soon as practicable after they have been prepared and are sufficiently dry.

Apply the prime coat to asphalt surfaces immediately after final rolling, and before any traffic has been allowed upon or the surface has hardened and glazed hindering the penetration of asphalt material.

Using a distributor (see **subsection 155.2**), uniformly apply asphalt material at the rate shown in the Contract Documents. Frequently check and adjust the spray nozzles and spray bar to obtain uniform distribution. Should any nozzle malfunction, immediately stop distribution. Correct any deficiency before distribution is resumed.

Only use hand sprayers for areas that can not be primed by normal operation of the distributor.

**e. Protection of Prime Coat After Application.** Maintain the prime coat and the surface of the subgrade or base course until it has been covered by the surface course or until final acceptance of the work. Clean all damaged areas of loose material, repair them satisfactorily and reapply the prime coat. Such maintenance and repair is at the Contractor's expense.

After 48 hours, the Engineer may require a light application of blotting material on specified areas to prevent damage from traffic. Use a clean fine sand or other approved material.

**f. Seasonal and Weather Limitations.** Construct asphalt prime coats between May 1 and October 15 when the ambient air temperature is 60°F and rising, and the weather is not rainy or foggy. These limitations may be modified with written approval from the Engineer.

**g. Pavement Smoothness.** Asphalt prime coat is excluded from profilograph testing, and not eligible for pay adjustments.

## **607 - ASPHALT PRIME COAT**

### **607.4 MEASUREMENT AND PAYMENT**

The Engineer will measure emulsified asphalt and cutback asphalt by the ton.

The Engineer will measure blotter material by either the ton or the cubic yard in the vehicle at the time and place of unloading or at other points as designated by the Engineer. Blotting material will not be paid for as such, but will be included in the quantities of cover material or aggregate for base course, provided in the Contract Documents.

Manipulation for prime coat will not be measured directly, but will be subsidiary to the item of manipulation for other phases of work. Any water for the preparation of the prime coat is subsidiary.

Payment for "Emulsified Asphalt (\*)" and "Cutback Asphalt (\*)" at the contract unit prices is full compensation for the specified work.

**608 - CHIP SEALS**

**SECTION 608**

**CHIP SEALS**

**608.1 DESCRIPTION**

Apply asphalt material to the existing surface, followed by an application of cover material, as specified in the Contract Documents.

**BID ITEMS**

Cover Material (\*)  
Cutback Asphalt (\*)  
Emulsified Asphalt (\*)  
Asphalt Cement (\*)  
Water (Flexible Pavement) (Set Price)  
Manipulation (Chip Seals)  
\*Type and Grade

**UNITS**

Cubic Yard  
Ton  
Ton  
Ton  
M Gallon  
Station

**608.2 MATERIALS**

Provide materials that comply with the applicable requirements.

Aggregate for Cover Material ..... **DIVISION 1100**  
Asphalt Material ..... **DIVISION 1200**  
Water ..... **DIVISION 2400**

**608.3 CONSTRUCTION REQUIREMENTS**

**a. Preparation of Surfaces.** Before applying asphalt material, clean all foreign material from the surface to be treated. Broom surface to remove dust.

**b. Protection of Adjacent Structures.** Protect the surfaces of all structures and other roadway appurtenances from damage or splatter of asphalt material. Restore any damaged or splattered appurtenances to their original condition at own expense.

**c. Temperature of Asphalt Materials at Time of Application.** Apply asphalt material at the temperature specified in **TABLE 601-1**, or as shown on the producer's Bill of Lading.

**d. Application of Asphalt Material.** Using a distributor (see **subsection 155.2**), uniformly apply asphalt material at the rate shown in the Contract Documents. Equip and operate the distributor to prevent asphalt material from dripping on the pavement.

At the beginning of each spread, start the application on a strip of building paper, approximately 3 feet in width and 1 foot longer than the spray bar. If the spray cut-off is not positive, use paper at the end of each spread. Remove and dispose of the paper in a satisfactory manner. Open the spray bar when the distributor is moving forward at proper speed, unless the distributor is equipped to apply the specified rate from a standing start. Correct any skipped areas or deficiencies. Construct junctions (joints) of spreads to obtain a smooth riding surface.

Do not spread more asphalt material than can be immediately covered.

Regulate the distribution of the asphalt material to obtain a uniform application. Do not allow the distributor to "blow".

Frequently check and adjust the angle of the spray nozzles and the height of the spray bar to obtain uniform distribution. If the spray bar rises as the load is removed, contributing to drilling and streaking, modify the distributor to maintain a constant spray bar height. Immediately stop distribution should any nozzle malfunction. Correct any deficiency before distribution is resumed.

**608 - CHIP SEALS**

**e. Application of Aggregate.** Immediately following the application of the asphalt material, spread cover material with a self-propelled aggregate spreader in quantities designated in the Contract Documents. The tires of the trucks or aggregate spreaders shall not come in contact with the fresh asphalt material at any time.

Do not allow the asphalt material to remain uncovered long enough to impair retention of the cover material. Do not apply the spread width of the cover material greater than 6 inches wider than the spread width of asphalt material.

Uniformly cover the asphalt before rolling. Equip and operate spreading equipment to provide complete coverage. Brooming, dragging or blading of the cover material is prohibited before initial rolling. Perform any rearrangement of the cover material by hand methods. Avoid overlapping applications of cover material and remove all spillage from the surface.

At the time of delivery to the roadway, the moisture content of the cover material shall not exceed 3% by weight plus ½ the water absorption of the aggregate. Do not let free moisture drain from the truck. The moisture limitations do not apply if lightweight aggregate is used.

When directed by the Engineer, moisten the cover material with water to eliminate or reduce the dust coating of the aggregate. Perform the moistening the day before the aggregate is used.

Any operation of equipment that results in displacement of the cover material or damage to the seal course is prohibited.

**f. Rates of Application of Aggregate.** When alternate types of cover material are shown in the Contract Documents, the quantities of aggregate and asphalt material are for the purpose of estimating and bidding only. Once the Contractor designates the alternate type of aggregate to be supplied, the total quantities to be used and paid for are determined by using the application rates in **TABLE 608-1**. No change in the contract unit price will be made.

The application rate shown in **TABLE 608-1** may be changed with written approval from the Engineer.

<b>TABLE 608-1: RATES OF APPLICATION FOR CHIP SEAL</b>				
<b>Type</b>	<b>Composition</b>	<b>Aggregate Cu. Yd./Mile 24 foot width*</b>	<b>Asphalt Material Gal/Sq. Yd. Residue*</b>	<b>Asphalt Type**</b>
CM-A	Sand-Gravel	105	0.20	CRS-1H
CM-B	Sand-Gravel	135	0.23	CRS-1H
CM-D	Crushed Sandstone	145	0.27	CRS-1H or RS-1H
CM-K	Limestone	140	0.24	RS-1H
CM-L-1	Lightweight	85	0.17	CRS-1H
CM-L-2	Lightweight	115	0.26	CRS-1H
CM-L-3	Lightweight	150	0.30	CRS-1H

\*Rates shown are estimated and will be adjusted to comply with actual field conditions.

\*\* Asphalt type may be changed with approval of the DME.

If the quantity of cover material computed from **TABLE 608-1** exceeds the amount used on the roadway, the Engineer will designate a stockpile location for this excess quantity. Locate the stockpile along the project, or at locations requiring a haul distance no longer than the most distant end of the project.

The maximum quantity of cover material to be stockpiled is as follows:

- The amount shown on the Contract Documents minus the amount used on the road when one type of cover material is shown in the Contract Documents.
- The amount determined by using the application rates in **TABLE 608-1** minus the amount used on the road when alternate types of cover material are shown in the Contract Documents.
- The amount specified by the Engineer minus the amount used on the road when the Engineer changes the application rates in **TABLE 608-1**.

Payment for the stockpiled material will be at the contract unit price per cubic yard of cover material.

**g. Manipulation.** Immediately following the application of cover material, embed using pneumatic rolling. Provide a minimum of 3 self-propelled pneumatic rollers. Check the tire pressures of all tires on all rollers every morning. Inflate all tires on a roller to the same pressure. Provide this information to the Engineer before work

## 608 - CHIP SEALS

begins. Complete the initial rolling within 5 minutes after application of cover material. If the air temperature is less than 70°F, then complete the initial rolling within 2 minutes after applying the aggregate. Proceed at a speed less than or equal to 5 miles per hour to prevent turning over aggregate. Make a minimum of 3 complete passes over the aggregate. Roll the aggregate so the entire width of the treatment area is covered in one pass of all the rollers. The total compacting width of each pneumatic-tired roller shall exceed 5 feet. The number of rollers for shoulders may be reduced based on the width of the shoulders and the width of the rollers.

If emulsified asphalt is used, cure the asphalt material a minimum of 4 hours before opening the roadway to unrestricted traffic. If polymer modified emulsified asphalt is used, the cure time shall be a minimum of 1 ½ hours before the traveled way is opened to unrestricted traffic. If traffic causes excessive chip loss, increase the cure time until excessive chip loss is eliminated.

On seals using CM-A, or B, the Engineer may require the use of a steel roller for one of the coverages, provided excessive crushing of the cover material does not occur.

Do not turn rollers on the sealed surface.

When required, apply additional cover material and roll it with the pneumatic rollers as directed by the Engineer.

Broom the loose cover material from the surface of the traveled way as soon as the asphalt material has cured enough to prevent damage by brooming or vehicular traffic. Continue periodic brooming until all loose aggregate has been removed. Perform a minimum of 1 light brooming of the cover material, before opening to traffic. Additional broomings may be required before opening to traffic to prevent the cover material from being picked up by moving vehicles. Broom excess cover material from the shoulder.

The Contractor may seal in 1 lane for the entire day.

When CM-B and cutback asphalt are specified in the Contract Documents, begin a second period of manipulation on the day following the first rolling, or as soon thereafter as weather conditions permit. This manipulation consists of spreading the loose cover material uniformly over the surface and rolling with the type of rollers specified by the Engineer. The rolling operation consists of 2 complete coverages of the previous day's work. Following the second day's rolling, broom excess cover material off the traveled way and shoulders, as directed by the Engineer.

**h. Maintenance of Completed Work.** When directed by the Engineer, add asphalt material and aggregate to completed portions of the project. All additional asphalt material and aggregate so ordered will be included in the pay quantities. Spreading and rolling of additional aggregate will not be paid for separately, but is considered as subsidiary to the item of "Manipulation (Chip Seals)".

If the shoulder vegetation is not sufficient to define the edge of the traveled way, broom and blade the excess cover material off the shoulder to provide delineation.

**i. Treatment of Adjacent Areas.** When shown in the Contract Documents, seal the existing intersections and entrances, mailbox turnouts, etc. having asphalt surfaces. Seal all widened areas. Asphalt and cover material for this work is included in the contract quantities and will be paid for at the contract unit price.

**j. Maintenance of Traffic.** Maintain traffic according to **DIVISION 800** and the following.

Coordinate all construction operations to result in the least practicable delay of traffic. Maintain one-way traffic and restrict traffic speeds to 30 MPH on bare pavement and 20 MPH on freshly applied seal. Use pilot cars to lead one-way traffic through the areas of distribution and curing. Coordinate the work so the pilot car completes a round trip in 15 minutes or less. Do not delay traffic at more than 2 separate locations of work on a project.

Station one flagger immediately ahead of the application of the asphalt material and one flagger immediately behind the section being cured. Move the signs and flaggers forward as the work progresses.

Complete all brooming activities before opening the traveled way to unrestricted traffic.

On projects where asphalt sealing is constructed in connection with other work from which traffic is detoured, the provisions of this subsection do not apply. Restrict the speed of all equipment traveling on the freshly applied seal to 20 MPH for 24 hours.

**k. Seasonal and Weather Limitations.**

(1) Construct asphalt sealing using cutback asphalt between May 1 and October 15, when the ambient air temperature is 60°F and rising.

(2) Construct asphalt sealing using emulsified asphalt between June 1 and September 15, when the ambient air temperature is 60°F and rising, and the pavement temperature is a minimum of 70°F.

## 608 - CHIP SEALS

(3) Construct asphalt sealing using asphalt cement between June 1 and September 1, when the ambient air temperature is 70°F and rising, and the pavement temperature is a minimum of 80°F.

When aggregate retention is unsatisfactory, suspend sealing. Do not seal when the surface is wet, or the weather is foggy or rainy. These limitations may be modified with written approval from the Engineer.

If the seal is damaged or lost, due to rain or wet pavement, repair or re-seal the damaged pavement.

**l. Observation Period.** If the chip seal is constructed in accordance with the seasonal limitations in **subsection 608.3k.**, the Engineer, along with the Contractor, will inspect the seal, 30 days after work is completed on the seal. If the seasonal limitations in **subsection 608.3k.** are modified, the Engineer, along with the Contractor, will inspect the seal between May 1 and April 1 the following year. Repair areas where there is no cover material left in place (bare areas) as directed by the Engineer:

- In 5% the wheel paths; and
- Individual areas  $\geq$  10 square yards; and
- Where the total square yards of bare areas is greater than 5% of the total square yards of the seal.

**m. Pavement Smoothness.** Chip seals are excluded from profilograph testing, and not eligible for pay adjustments.

### 608.4 MEASUREMENT AND PAYMENT

The Engineer will measure cover material by the cubic yard. The material will be measured in the vehicle at the time and place of unloading. No deductions will be made for moisture in the cover material.

The Engineer will measure asphalt material by the ton. Deductions will be made for the number of tons that are not placed on the road surface.

The Engineer will measure manipulation by the Station, along the centerline. On divided highways, the Engineer will measure manipulation by the Station, along the centerline of each divided direction. This includes all widened and irregular areas and irregular variations in depth.

The Engineer will measure ordered water by the M Gallon by means of calibrated tanks or water meters.

Payment for "Cover Material", "Cutback Asphalt", "Emulsified Asphalt", "Asphalt Cement" and "Manipulation (Chip Seals)" at the contract unit prices and "Water (Flexible Pavement) (Set Price)" at the contract set unit price is full compensation for the specified work.

When the Contract Documents call for asphalt cement for chip seals, the following provisions apply:

- If the work is not completed by September 1, and when ordered by the District Engineer in writing, change the type of asphalt material to cutback asphalt.
- If approved changes are made, the unit price for cutback asphalt will be the contract price for asphalt cement plus or minus the difference in the invoice price of the two materials at the refinery at the time of application.

Such measurement and payment is full compensation for the work specified.

609 - SINGLE ASPHALT SURFACE TREATMENT

SECTION 609

SINGLE ASPHALT SURFACE TREATMENT

609.1 DESCRIPTION

Construct a wearing surface composed of an asphalt prime coat followed by the application of an asphalt surfacing and cover material as specified in the Contract Documents.

**BID ITEMS**

- Cover Material (\*)
- Cutback Asphalt (\*) (\*\*)
- Emulsified Asphalt (\*) (\*\*)
- Asphalt Cement (\*) (\*\*)
- Water (Flexible Pavement) (Set Price)
- Manipulation (S.A.S.T.)

**UNITS**

- Cubic Yard
- Ton
- Ton
- Ton
- M Gallon
- Station

\*Type and Grade

\*\*"Prime" denotes material to be used for prime.

"Seal" denotes material to be used for seal.

609.2 MATERIALS

Provide materials that comply with the applicable requirements.

Aggregates for Cover Material .....	<b>DIVISION 1100</b>
Asphalt Material .....	<b>DIVISION 1200</b>
Water .....	<b>DIVISION 2400</b>

609.3 CONSTRUCTION REQUIREMENTS

**a. Preparation of Road Surfaces.**

(1) Earth subgrade, water-bound base courses and subbases. Before distributing asphalt materials, blade the surface of the roadbed to a smooth, uniform section. Remove all loose materials. Shape, blade and broom side roads that receive asphalt treatment, at the same time as the roadbed surface. When required by the Engineer, give the water-bound base course or subgrade a light application of water (approximately 0.1 gallon per square yard) before the asphalt material is applied.

(2) Asphalt surfaces. Before applying asphalt material, clean all foreign material from the surface to be treated. Broom surface to remove dust. When required by the Engineer, give the asphalt surface a light application of water (approximately 0.1 gallon per square yard) before the asphalt material is applied.

**b. Protection of Adjacent Structures.** Protect the surfaces of all structures and other roadway appurtenances from damage or splatter of asphalt material. Restore any damaged or splattered appurtenances to their original condition at own expense.

**c. Temperature of Asphalt Materials at Time of Application.** Apply asphalt material at the temperature specified in **TABLE 601-1**, or as shown on the producer's Bill of Lading.

**d. Application of Prime Coat.** Apply the prime coat to earth subgrades, water-bound base courses and subbases as soon as practicable after they have been prepared and are sufficiently dry.

Apply the prime coat to asphalt surfaces immediately after final rolling and before any traffic has been allowed, or when the surface has hardened and glazed so penetration of asphalt material is hindered.

Using a distributor (see **subsection 155.2**), uniformly apply asphalt material at the rate shown in the Contract Documents. Frequently check and adjust the spray nozzles and spray bar to obtain uniform distribution. Should any nozzle malfunction, immediately stop distribution. Correct any deficiency before distribution is resumed.

Only use hand sprayers for areas that can not be primed by normal operation of the distributor.

## 609 - SINGLE ASPHALT SURFACE TREATMENT

**e. Preparation of Road Surfaces for Seal Coat.** After the prime coat has thoroughly penetrated the subgrade, and before applying asphalt material, clean the surface to be treated of all foreign material and broom it as necessary to remove dust.

**f. Application of Asphalt Material for Seal Coat.** Using a distributor, uniformly apply asphalt material at the rate shown in the Contract Documents. Equip and operate the distributor to prevent asphalt material from dripping on the pavement.

At the beginning of each spread, use a strip of building paper, approximately 3 feet in width and 1 foot longer than the spray bar. If the spray cut-off is not positive, use paper at the end of each spread. Remove the paper and dispose of it in a satisfactory manner. Open the spray bar when the distributor is moving forward at proper speed, unless it is equipped to apply the specified rate from a standing start. Correct any skipped areas or deficiencies. Carefully make junctions of spreads to obtain a smooth riding surface.

Do not spread more asphalt material than can be immediately covered. Do not allow the asphalt material to remain uncovered long enough to impair retention of the cover material. Do not exceed the spread width of the cover material with the spread width of asphalt material by more than 6 inches.

Regulate the distribution of the asphalt material to obtain a uniform application. Do not allow the distributor to "blow".

Frequently check and adjust the angle of the spray nozzles and the height of the spray bar to obtain uniform distribution. If the rise of the spray bar as the load is removed is excessive and contributes to drilling and streaking, modify the distributor to maintain a constant spray bar height. Should any nozzle malfunction, immediately stop distribution. Correct any deficiency before distribution is resumed.

**g. Application of Aggregate for Seal Coat.** Immediately following the application of the asphalt material, spread cover material with a self-propelled aggregate spreader in quantities designated in the Contract Documents.

The tires of the trucks or aggregate spreaders shall not come in contact with the fresh asphalt material at any time.

Do not allow the asphalt material to remain uncovered long enough to impair retention of the cover material. Do not apply the spread width of the cover material greater than 6 inches wider than the spread width of asphalt material.

Uniformly cover the asphalt before rolling. Equip and operate spreading equipment to provide complete coverage. Brooming, dragging or blading of the cover material is prohibited before initial rolling. Perform any rearrangement of the cover material by hand methods. Avoid overlapping applications of cover material and remove all spillage from the surface.

At the time of delivery to the roadway, the moisture content of the cover material shall not exceed 3% by weight plus  $\frac{1}{2}$  the water absorption of the aggregate. Do not let free moisture drain from the truck. The moisture limitations do not apply if lightweight aggregate is used.

When directed by the Engineer, moisten the cover material with water to eliminate or reduce the dust coating of the aggregate. Perform the moistening the day before the aggregate is used.

Any operation of equipment that results in displacement of the cover material or damage to the seal course is prohibited.

**h. Rates of Application of Cover Material for Seal Coat.** When alternate types of cover material are shown in the Contract Documents, the quantities of aggregate and asphalt material are for the purpose of estimating and bidding only. Once the Contractor designates the alternate type of aggregate to be supplied, the total quantities to be used and paid for are determined by using the application rates in **TABLE 608-1**. No change in the contract unit price will be made.

The application rate shown in **TABLE 608-1** may be changed with written approval from the Engineer.

If the quantity of cover material computed from **TABLE 608-1** exceeds the amount used on the roadway, the Engineer will designate a stockpile location for this excess quantity. Locate the stockpile along the project, or at locations requiring a haul distance no longer than the most distant end of the project.

The maximum quantity of cover material to be stockpiled is as follows:

- The amount shown on the Contract Documents minus the amount used on the road when one type of cover material is shown in the Contract Documents.
- The amount determined by using the application rates in **TABLE 608-1** minus the amount used on the road when alternate types of cover material are shown in the Contract Documents.



## 609 - SINGLE ASPHALT SURFACE TREATMENT

- The amount specified by the Engineer minus the amount used on the road when the Engineer changes the application rates in **TABLE 608-1**.

Payment for the stockpiled material will be at the contract unit price per cubic yard of cover material.

**i. Manipulation of Completed work.** Immediately following the application of cover material, embed using pneumatic rolling. Provide a sufficient number of pneumatic rollers to complete the initial roller coverage within 15 minutes after the application of cover material. Continue pneumatic rolling until a total of 7 complete coverages are obtained. Keep the speed of rollers such that aggregate displacement is minimized. Vary the weight of the rollers to embed the cover material as shown in the Contract Documents.

If emulsified asphalt is used, cure the asphalt material a minimum of 4 hours before opening the roadway to unrestricted traffic. If polymer modified emulsified asphalt is used, the cure time shall be a minimum of 1 ½ hours before the traveled way is opened to unrestricted traffic. If traffic causes excessive chip loss, increase the cure time until excessive chip loss is eliminated.

On seals using CM-A, B or E, the Engineer may require the use of a steel roller for one of the coverages, provided excessive crushing of the cover material does not occur.

Control the rolling sequence so it shall be unnecessary for one roller to turn out to permit another roller to pass. Do not turn rollers on the sealed surface.

When required, apply additional cover material and roll it with the pneumatic rollers as directed by the Engineer.

Provide self-propelled rollers.

Broom the loose cover material from the surface of the traveled way as soon as the asphalt material has cured enough to prevent damage by brooming or vehicular traffic. Continue periodic brooming until all loose aggregate has been removed. Perform a minimum of 1 light brooming of the cover material before opening to traffic. Additional broomings may be required before opening to traffic to prevent the cover material from being picked up by moving vehicles. Broom excess cover material from the shoulder.

The Contractor may seal in 1 lane for the entire day.

When CM-B and cutback asphalt are specified in the Contract Documents, begin a second period of manipulation on the day following the first rolling, or as soon thereafter as weather conditions permit. This manipulation consists of spreading the loose cover material uniformly over the surface and rolling with the type of rollers specified by the Engineer. The rolling operation consists of 2 complete coverages of the previous day's work. Following the second day's rolling, broom excess cover material off the traveled way and shoulders, as directed by the Engineer.

**j. Maintenance of Completed Work.** When directed by the Engineer, add asphalt material and aggregate to completed portions of the project. All additional asphalt material and aggregate so ordered will be included in the pay quantities. Spreading and rolling of additional aggregate will not be paid for separately. It is considered as subsidiary to the item of "Manipulation (S.A.S.T.)".

If the shoulder vegetation is not sufficient to define the edge of the traveled way, broom and blade the excess cover material off the shoulder to provide delineation.

**k. Treatment of Adjacent Areas.** When shown in the Contract Documents, seal the existing intersections and entrances, mailbox turnouts, etc. having asphalt surfaces. Seal all widened areas. Asphalt and cover material for this work is included in the contract quantities and will be paid for at the contract unit price.

### **l. Seasonal and Weather Limitations.**

(1) Construct asphalt sealing using cutback asphalt between May 1 and October 15, when the ambient air temperature is 60°F and rising.

(2) Construct asphalt sealing using emulsified asphalt between June 1 and September 15, when the ambient air temperature is 60°F and rising, and the pavement temperature is a minimum of 70°F.

(3) Construct asphalt sealing using asphalt cement between June 1 and September 1, when the ambient air temperature is 70°F and rising, and the pavement temperature is a minimum of 80°F.

When aggregate retention is unsatisfactory, suspend sealing. Do not seal when the surface is wet, or the weather is foggy or rainy. These limitations may be modified with written approval from the Engineer.

If the seal is damaged or lost, due to rain or wet pavement, repair or re-seal the damaged pavement.

## 609 - SINGLE ASPHALT SURFACE TREATMENT

**m. Pavement Smoothness.** Single asphalt surface treatment is excluded from profilograph testing, and not eligible for pay adjustments.

### 609.4 MEASUREMENT AND PAYMENT

The Engineer will measure cover material by the cubic yard. The material will be measured in the vehicle at the time and place of unloading. No deductions will be made for moisture in the cover material.

The Engineer will measure asphalt material by the ton. Deductions will be made for the number of tons that are not placed on the road surface.

The Engineer will measure manipulation by the Station, along the centerline. On divided highways, the Engineer will measure manipulation by the Station, along the centerline of each divided direction. This includes all widened and irregular areas and irregular variations in depth.

The Engineer will measure ordered water by the M Gallon by means of calibrated tanks or water meters.

Payment for "Cover Material", "Cutback Asphalt", "Emulsified Asphalt", "Asphalt Cement" and "Manipulation (S.A.S.T.)" at the contract unit prices and "Water (Flexible Pavement) (Set Price)" at the contract set unit price is full compensation for the specified work.

When the Contract Documents call for asphalt cement for asphalt sealing, the following provisions apply:

- If the work is not completed by September 1, and when ordered by the District Engineer in writing, change the type of asphalt material to cutback asphalt.
- If approved changes are made, the unit price for cutback asphalt will be the contract price for asphalt cement plus or minus the difference in the invoice price of the two materials at the refinery at the time of application.

Such measurement and payment is full compensation for the work specified.

**610 - DOUBLE ASPHALT SURFACE TREATMENT**

**SECTION 610**

**DOUBLE ASPHALT SURFACE TREATMENT**

**610.1 DESCRIPTION**

Construct a wearing surface composed of an asphalt prime coat followed by the applications of 2 asphalt seal coats and cover material as specified in the Contract Documents.

**BID ITEMS**

**UNITS**

Cover Material (*)	Cubic Yard
Cutback Asphalt (*) (**)	Ton
Emulsified Asphalt (*) (**)	Ton
Asphalt Cement (*) (**)	Ton
Water (Flexible Pavement) (Set Price)	M Gallon
Manipulation (D.A.S.T.)	Station

\*Type and Grade

\*\* "Prime" denotes material to be used for prime.

"Seal" denotes material to be used for seal.

**610.2 MATERIALS**

Provide materials that comply with the applicable requirements.

Aggregate for Cover Material .....	<b>DIVISION 1100</b>
Asphalt Material .....	<b>DIVISION 1200</b>
Water .....	<b>DIVISION 2400</b>

**610.3 CONSTRUCTION REQUIREMENTS**

**a. Preparation of Road Surfaces.**

(1) Earth subgrade, water-bound base courses and subbases. Before distributing asphalt materials, blade the surface of the roadbed to a smooth, uniform section. Remove all loose materials. Shape, blade and broom side roads that receive asphalt treatment, at the same time as the roadbed surface. When required by the Engineer, give the water-bound base course or subgrade a light application of water (approximately 0.1 gallon per square yard) before the asphalt material is applied.

(2) Asphalt surfaces. Before applying asphalt material, clean all foreign material from the surface to be treated. Broom surface to remove dust. When required by the Engineer, give the asphalt surface a light application of water (approximately 0.1 gallon per square yard) before the asphalt material is applied.

**b. Protection of Adjacent Structures.** Protect the surfaces of all structures and other roadway appurtenances from damage or splatter of asphalt material. Restore any damaged or splattered appurtenances to their original condition at own expense.

**c. Temperature of Asphalt Materials at Time of Application.** Apply asphalt material at the temperature specified in **TABLE 601-1**, or as shown on the producer's Bill of Lading.

**d. Application of Prime Coat.** Apply the prime coat to earth subgrades, water-bound base courses and subbases as soon as practicable after they have been prepared and are sufficiently dry.

Apply the prime coat to asphalt surfaces immediately after final rolling and before any traffic has been allowed upon or when the surface has hardened and glazed so penetration of asphalt material is hindered.

Using a distributor (see **subsection 155.2**), uniformly apply asphalt material at the rate shown in the Contract Documents. Frequently check and adjust the spray nozzles and spray bar to obtain uniform distribution. Should any nozzle malfunction, immediately stop distribution. Correct any deficiency before distribution is resumed.

Only use hand sprayers for areas that can not be primed by normal operation of the distributor.

## 610 - DOUBLE ASPHALT SURFACE TREATMENT

**e. Preparation of Road Surfaces for First Seal Coat.** After the prime coat has thoroughly penetrated the subgrade, and before applying asphalt material, clean the surface to be treated of all foreign material and broom it as necessary to remove dust.

**f. Application of Asphalt Material for First Seal Coat.** Using a distributor, uniformly apply asphalt material at the rate shown in the Contract Documents. Equip and operate the distributor to prevent asphalt material from dripping on the pavement.

At the beginning of each spread, use a strip of building paper, approximately 3 feet in width and 1 foot longer than the spray bar. If the spray cut-off is not positive, use paper at the end of each spread. Remove the paper and dispose of it in a satisfactory manner. Open the spray bar when the distributor is moving forward at proper speed, unless it is equipped to apply the specified rate from a standing start. Correct any skipped areas or deficiencies. Carefully make junctions of spreads to obtain a smooth riding surface.

Do not spread more asphalt material than can be immediately covered. Do not allow the asphalt material to remain uncovered long enough to impair retention of the cover material. Do not exceed the spread width of the cover material with the spread width of asphalt material by more than 6 inches.

Regulate the distribution of the asphalt material to obtain a uniform application. Do not allow the distributor to "blow".

Check and adjust the angle of the spray nozzles and the height of the spray bar frequently to obtain uniform distribution. If the rise of the spray bar as the load is removed is excessive and contributes to drilling and streaking, modify the distributor to maintain a constant spray bar height. Should any nozzle malfunction, immediately stop distribution. Correct any deficiency before distribution is resumed.

**g. Application of Aggregate for First Seal Coat.** Immediately following the application of the asphalt material, spread cover material with a self-propelled aggregate spreader in quantities designated in the Contract Documents. The tires of the trucks or aggregate spreaders shall not come in contact with the fresh asphalt material at any time.

Do not allow the asphalt material to remain uncovered long enough to impair retention of the cover material. Do not apply the spread width of the cover material greater than 6 inches wider than the spread width of asphalt material.

Uniformly cover the asphalt before rolling. Equip and operate spreading equipment to provide complete coverage. Brooming, dragging or blading of the cover material is prohibited before initial rolling. Perform any rearrangement of the cover material by hand methods. Avoid overlapping applications of cover material and remove all spillage from the surface.

At the time of delivery to the roadway, the moisture content of the cover material shall not exceed 3% by weight plus  $\frac{1}{2}$  the water absorption of the aggregate. Do not let free moisture drain from the truck. The moisture limitations do not apply if lightweight aggregate is used.

When directed by the Engineer, moisten the cover material with water to eliminate or reduce the dust coating of the aggregate. Perform the moistening the day before the aggregate is used.

Any operation of equipment that results in displacement of the cover material or damage to the seal course is prohibited.

**h. Rates of Application of Cover Material for First Seal Coat.** When alternate types of cover material are shown in the Contract Documents, the quantities of aggregate and asphalt material are for the purpose of estimating and bidding only. Once the Contractor designates the alternate type of aggregate to be supplied, the total quantities to be used and paid for are determined by using the application rates in **TABLE 608-1**. No change in the contract unit price will be made.

The application rate shown in **TABLE 608-1** may be changed with written approval from the Engineer.

If the quantity of cover material computed from **TABLE 608-1** exceeds the amount used on the roadway, the Engineer will designate a stockpile location for this excess quantity. Locate the stockpile along the project, or at locations requiring a haul distance no longer than the most distant end of the project.

The maximum quantity of cover material to be stockpiled is as follows:

- The amount shown on the Contract Documents minus the amount used on the road when one type of cover material is shown in the Contract Documents.
- The amount determined by using the application rates in **TABLE 608-1** minus the amount used on the road when alternate types of cover material are shown in the Contract Documents.

## 610 - DOUBLE ASPHALT SURFACE TREATMENT

- The amount specified by the Engineer minus the amount used on the road when the Engineer changes the application rates in **TABLE 608-1**.

Payment for the stockpiled material will be at the contract unit price per cubic yard of cover material.

**i. Manipulation.** Immediately following the application of cover material, embed using pneumatic rolling. Provide a sufficient number of pneumatic rollers to complete the initial roller coverage within 15 minutes after the application of cover material. Continue pneumatic rolling until a total of 7 complete coverages are obtained. Keep the speed of rollers such that aggregate displacement is minimized. Vary the weight of the rollers to embed the cover material as shown in the Contract Documents.

If emulsified asphalt is used, cure the asphalt material a minimum of 4 hours before opening the roadway to unrestricted traffic. If polymer modified emulsified asphalt is used, the cure time shall be a minimum of 1 ½ hours before the traveled way is opened to unrestricted traffic. If traffic causes excessive chip loss, increase the cure time until excessive chip loss is eliminated.

On seals using CM-A, B or E, the Engineer may require the use of a steel roller for one of the coverages, provided excessive crushing of the cover material does not occur.

Control the rolling sequence so it shall be unnecessary for one roller to turn out to permit another roller to pass. Do not turn rollers on the sealed surface.

When required, apply additional cover material and roll it with the pneumatic rollers as directed by the Engineer.

Provide self-propelled rollers.

Broom the loose cover material from the surface of the traveled way as soon as the asphalt material has cured enough to prevent damage by brooming or vehicular traffic. Continue periodic brooming until all loose aggregate has been removed. Perform a minimum of 1 light brooming of the cover material before opening to traffic. Additional broomings may be required before opening to traffic to prevent the cover material from being picked up by moving vehicles. Broom excess cover material from the shoulder.

The Contractor may seal in 1 lane for the entire day.

When CM-B and cutback asphalt are specified in the Contract Documents, begin a second period of manipulation on the day following the first rolling, or as soon thereafter as weather conditions permit. This manipulation consists of spreading the loose cover material uniformly over the surface and rolling with the type of rollers specified by the Engineer. The rolling operation consists of 2 complete coverages of the previous day's work. Following the second day's rolling, broom excess cover material off the traveled way and shoulders, as directed by the Engineer.

**j. Maintenance of First Seal Coat.** When directed by the Engineer, add asphalt material and aggregate to completed portions of the project. All additional asphalt material and aggregate so ordered will be included in the pay quantities. Spreading and rolling of additional aggregate will not be paid for separately but is considered as subsidiary to the item of "Manipulation (D.A.S.T.)".

If the shoulder vegetation is not sufficient to define the edge of the traveled way, broom and blade the excess cover material off the shoulder to provide delineation.

**k. Treatment of Adjacent Areas.** When shown in the Contract Documents, seal the existing intersections and entrances, mailbox turnouts, etc. having asphalt surfaces. Seal all widened areas. Asphalt and cover material for this work is included in the contract quantities and will be paid for at the contract unit price.

**l. Second Seal Coat.** If the asphalt material consists of cutback asphalt, do not apply the second seal coat until 60 days after the application of the first seal coat, unless shown otherwise in the Contract Documents.

Immediately prior to the second seal coat application, clean the surface of all foreign material, and broom to remove dust and excess cover material. Exercise care not to dislodge any cover material which is embedded in the asphalt material. Apply the second seal coat according to the provisions for the First Seal Coat in **subsections 610.3f. thru i.** Do not use brooms to shift the cover material until the initial rolling is complete, and until the asphalt material has sufficiently cured to hold the cover material. Perform any rearrangement of the cover material during the initial rolling by hand methods.

Continue rolling until the entire surface has been covered a minimum of 7 times with a pneumatic roller. Operate rollers at speeds which shall not displace the aggregate.

## 610 - DOUBLE ASPHALT SURFACE TREATMENT

**m. Maintenance of Completed Work.** Maintain the completed surface for a period of 5 days after the project or portions of the project are open to traffic. If for reasons beyond the Contractor's control, traffic can not be routed over the work upon completion of the project, maintain the surface for a period of 5 days after completion of the second seal coat. Maintenance consists of the following:

(1) Make one, complete coverage each day of the 5 days after the project or portions of the project are open to traffic with a light blade equipped with broom drag followed by a pneumatic roller. If weather and roadbed conditions are such that the dragging and rolling would not be beneficial to the surface the daily dragging and rolling may be omitted with approval of the Engineer.

(2) The application of additional asphalt material, aggregate, dragging and rolling or all of these operations may be required.

Asphalt material and aggregate ordered by the Engineer used in the maintenance work will be included in the quantities of these materials for which payment is to be made. Additional manipulation required for the maintenance work will not be paid for separately, but will be considered as subsidiary work to the item of "Manipulation (D.A.S.T.)" included in the Contract Documents.

**n. Treatment of Adjacent Areas.** When shown in the Contract Documents, perform the second seal on the same areas as the first seal, including existing intersections and entrances, mailbox turnouts, all widened areas etc. Asphalt and cover material for this work is included in the contract quantities and will be paid for at the contract unit.

**o. Maintenance of Traffic.** Maintain traffic according to **DIVISION 800** and the following.

Coordinate all construction operations to result in the least practicable delay of traffic. Maintain one-way traffic and restrict traffic speeds to 30 MPH on bare pavement and 20 MPH on freshly applied seal. Use pilot cars to lead one-way traffic through the areas of distribution and curing. Coordinate the work so the pilot car completes a round trip in 15 minutes or less. Do not delay traffic at more than 2 separate locations of work on a project.

Station one flagger immediately ahead of the application of the asphalt material and one flagger immediately behind the section being cured. Move the signs and flaggers forward as the work progresses.

Complete all brooming activities before opening the traveled way to unrestricted traffic.

On projects where asphalt sealing is constructed in connection with other work from which traffic is detoured, the provisions of this subsection do not apply. Restrict the speed of all equipment traveling on the freshly applied seal to 20 MPH for 24 hours.

**p. Seasonal and Weather Limitations.**

(1) Construct asphalt sealing using cutback asphalt between May 1 and October 15, when the ambient air temperature is 60°F and rising.

(2) Construct asphalt sealing using emulsified asphalt between June 1 and September 15, when the ambient air temperature is 60°F and rising, and the pavement temperature is a minimum of 70°F.

(3) Construct asphalt sealing using asphalt cement between June 1 and September 1, when the ambient air temperature is 70°F and rising, and the pavement temperature is a minimum of 80°F.

When aggregate retention is unsatisfactory, suspend sealing. Do not seal when the surface is wet, or the weather is foggy or rainy. These limitations may be modified with written approval from the Engineer.

If the seal is damaged or lost, due to rain or wet pavement, repair or re-seal the damaged pavement.

**q. Pavement Smoothness.** Double asphalt surface treatment is excluded from profilograph testing, and not eligible for pay adjustments.

### 610.4 MEASUREMENT AND PAYMENT

The Engineer will measure cover material by the cubic yard. The material will be measured in the vehicle at the time and place of unloading. No deductions will be made for moisture in the cover material.

The Engineer will measure asphalt material by the ton. Deductions will be made for the number of tons that are not placed on the road surface.

The Engineer will measure manipulation by the Station, along the centerline. On divided highways, the Engineer will measure manipulation by the Station, along the centerline of each divided direction. This includes all widened and irregular areas and irregular variations in depth.

The Engineer will measure ordered water by the M Gallon by means of calibrated tanks or water meters.

## 610 - DOUBLE ASPHALT SURFACE TREATMENT

Payment for "Cover Material", "Cutback Asphalt", "Emulsified Asphalt", "Asphalt Cement" and "Manipulation (D.A.S.T.)" at the contract unit prices and "Water (Flexible Pavement) (Set Price)" at the contract set unit price is full compensation for the specified work.

When the Contract Documents call for asphalt cement for asphalt sealing, the following provisions apply:

- If the work is not completed by September 1, and when ordered by the District Engineer in writing, change the type of asphalt material to cutback asphalt.
- If approved changes are made, the unit price for cutback asphalt will be the contract price for asphalt cement plus or minus the difference in the invoice price of the two materials at the refinery at the time of application.

Such measurement and payment is full compensation for the work specified.

**611 - HOT MIX ASPHALT (HMA)-COMMERCIAL GRADE**

**SECTION 611**

**HOT MIX ASPHALT (HMA)-COMMERCIAL GRADE**

**611.1 DESCRIPTION**

Construct the designated class of HMA-Commercial Grade asphalt pavement, as shown in the Contract Documents.

Class A HMA-Commercial Grade is intended for all areas that are not Class B locations. Class A includes permanent traffic areas and temporary traffic areas with moderate to high volumes of vehicular traffic such as driving lanes, auxiliary lanes and shoulders.

Class B HMA-Commercial Grade is intended for non-traffic areas and short-term temporary traffic areas with a low volume of vehicular traffic.

**BID ITEMS**

HMA-Commercial Grade (Class \*)  
 HMA-Commercial Grade (Class \*) (Patching)  
 \*A or B

**UNITS**

Ton  
 Ton

**611.2 MATERIALS**

**a. Aggregates.** Provide individual aggregates that comply with **DIVISION 1100**.

**b. Asphalt.** Provide performance graded asphalt binder that complies with **DIVISION 1200**. Provide asphalt for tack coat suitable for the intended use and approved by the Engineer.

**c. Mix Design.** Using forms provided by KDOT, submit a mix design for the designated class of HMA-Commercial Grade to the DME for review and approval. When requested by the Engineer, submit a sufficient quantity of materials to verify the mix design.

Submit a mix design that complies with these requirements:

(1) **TABLE 611-1**, Class A and Class B HMA-Commercial Grade Mix Criteria: Unless the Engineer approves otherwise or shown elsewhere in the Contract Documents, use a SM-12.5A or SR-12.5A (**TABLE 611-2**) for Class A. Use any mix designation listed in **TABLE 611-2** for Class B.

<b>TABLE 611-1: HMA-COMMERCIAL GRADE CLASS A and CLASS B MIX CRITERIA</b>			
	<b>CLASS A</b>	<b>CLASS B</b>	
<b>AGGREGATE:</b>			
Coarse Angularity (min.%)	75	50	
Uncompacted Voids-Fine (min. %)	42	40	
Sand Equivalent (min. %)	40	40	
Natural sand (max. %)	35	-	
Reclaimed Asphalt Pavement (RAP) (max. %)	25	50	
<b>Binder:</b>	PG64-22 or PG58-28 <sup>1</sup>	PG58-28 or PG64-22	
<b>COMPACTION REVOLUTIONS:</b>		(A) <sup>3</sup>	(B) <sup>3</sup>
N <sub>ini</sub>	7	6	7
N <sub>des</sub>	75	50	75
N <sub>max</sub>	115	75	115
Level of Compaction at N <sub>ini</sub>	≤90.5	≤91.5	≤91.5
<b>MIX:</b>			
VFA	65 – 78	66-80	65 – 78
Tensile Strength Ratio (TSR) (min. %)	80 <sup>2</sup>	-	-

<sup>1</sup>In permanent locations with an asphalt mixture containing Recycled Asphalt Shingles (RAS) or 16% to 25% RAP, use PG58-28. In all other locations, the Contractor may use either grade of binder.

<sup>2</sup>Meet the minimum TSR requirement for design only. Depending on the anticipated exposure to the environment, the DME may waive the TSR requirement.

<sup>3</sup>Use either column A or B, Contractor's option.



## 611 - HOT MIX ASPHALT (HMA)-COMMERCIAL GRADE

If RAP or RAS is used, inform the Engineer as to the source and type of RAP and RAS. Provide RAP that is reasonably free of contamination, uniform in composition (similar to RAP gradation shown on mix design) and has passed through a 2 1/4" screen or grizzly. The Engineer will accept the RAP and RAS based on a visual inspection.

The Engineer may approve the use of an asphalt mixture (listed in **TABLE 611-2**) that is produced, tested and complies with **SECTION 602**. If used, QC/QA testing is required.

(2) **TABLE 611-2**, Mix Design Requirements.

<b>TABLE 611-2: MIX DESIGN REQUIREMENTS (Master Grading Limits and VMA)</b>								
Nominal Maximum Size & Mix Designation	Percent Retained - Square Mesh Sieves							Min. VMA (%)
	1"	3/4"	1/2"	3/8"	No. 4	No. 8	No. 200	
SM-9.5A			0	0-10	10 min.	33-53	90.0-98.0	14.5
SR-9.5A			0-2	0-10	10 min.	33-53	90.0-98.0	14.5
SM-9.5T			0	0-10	10 min.	53-68	90.0-98.0	14.5
SR-9.5T			0-2	0-10	10 min.	53-68	90.0-98.0	14.5
SM-12.5A		0	0-10	10 min.		42-61	90.0-98.0	13.5
SR-12.5A		0-2	0-10	10 min.		42-61	90.0-98.0	13.5
SM-19A	0	0-10	10 min.			51-65	92.0-98.0	13.0
SR-19A	0-2	0-10	10 min.			51-65	92.0-98.0	13.0

- Meet the minimum VMA requirements with design only.
- Use an air void target of 4% (at  $N_{des}$ ) to establish binder content.
- Using the combined gradation (RAP and RAS, if any, and virgin aggregate), select a single point for each sieve within the master grading limits and the No. 16, No. 30, No. 50 and No. 100 sieves. Also, provide the combined virgin aggregate gradation.
- When controlling a virgin mix by cold feed gradation testing, apply single point tolerances in **TABLE 611-3** to the design single points for the virgin aggregate. Do not exceed the tolerances for the Master Grading Limits.
- When controlling a mix that contains RAP or RAS by cold feed virgin gradation testing, apply single point tolerances in **TABLE 611-3** to the design single points for the virgin aggregate. The tolerances may exceed the Master Grading Limits.
- If RAP is used, calculate the Effective Specific Gravity ( $G_{se}$ ) of the RAP as shown in subsection 5.10.4 – Calculations for the Marshall Mix Design of Bituminous Mixtures, Part V and used as the  $G_{sb}$  of the RAP. If RAS is used, calculate the Effective Specific Gravity ( $G_{se}$ ) of the RAS as shown in subsection 5.10.4, Part V and use as the  $G_{sb}$  of the RAS.

<b>TABLE 611-3: SINGLE POINT TOLERANCES</b>								
Nominal Maximum Size & Mix Designation	Percent Retained - Square Mesh Sieves							
	3/8"	No. 4	No. 8	No. 16	No. 30	No. 50	No. 100	No. 200
SM-9.5A or SR-9.5A		±5	±5	±5	±4	±4	±3	±2
SM-9.5T or SR-9.5T		±6	±5	±5	±4	±3	±3	±2
SM-12.5A or SR-12.5A	±6	±6	±5	±5	±4	±4	±3	±2
SM-19A or SR-19A	±6	±6	±5	±5	±4	±4	±4	±2

Comply with the certification requirements for the appropriate categories listed in the Policy and Procedure Manual for the Certified Inspection and Testing Training (CIT<sup>2</sup>) Program. Use calibrated testing equipment with prescribed procedures in the KDOT Construction Manual, Part V, Section 5.2.7.

## 611 - HOT MIX ASPHALT (HMA)-COMMERCIAL GRADE

**d. Process Control.** Prior to making a single point or proportion change, receive approval from the Engineer. Depending upon the change, the Engineer may require another mix design before granting approval. On the first Lot only of production of any mix designation, any gradation penalty for the entire Lot will be assessed on the basis of the revised design job-mix (if any), provided no change in asphalt content is required as a result of the revision. For changes made in the design job-mix on subsequent Lots, computation of adjusted payment will not be retroactive within the Lots. Make any gradation change for the Lot before starting the gradation testing for that Lot.

During mix production on non-QC/QA projects, the Engineer may conduct tests (randomly located) to verify compliance with the approved mix design, and make adjustments to the binder content (Note: Plant produced mix may have a lower VMA and require a reduction in binder content.).

On projects with less than 500 tons of commercial grade asphalt mixture, testing (QC/QA or cold-feed gradations) is at the Engineer's discretion. On projects with 500 tons or more, testing of the asphalt mixture is required:

- The Engineer will test the combined virgin gradation at a frequency of 1 test for each 500 ton Lot or fraction thereof.
- On projects with more than 2000 tons of HMA-Commercial Grade mixture the Contractor may request the lot be increased to 750 ton provided the following criteria are met:
  - The plant is producing more than 500 tons of HMA-Commercial Grade mixture per day;
  - Previous 3 consecutive lots were produced without penalty; and
  - Provide immediate notification of lot size change to the Engineer any time a change is made.
- If any lot fails to meet all of the above criteria, the lot size shall resort to 500 tons until such time that the aforementioned criteria are met.
- Or, the Contractor and Engineer will test (QC/QA respectively) the asphalt mixture according to the testing requirements and frequencies in Part V, Appendix B.

KDOT will perform tests at the Contractor's lab or at a location agreed to by the Engineer and Contractor. Testing will be completed and the results reported to the Contractor within 24 hours. If the test results indicate there is non-compliant material, make the appropriate adjustments to the mix proportions to comply with the approved mix design.

**e. Suspension of Mixture Production.** If the results of 2 consecutive cold-feed gradation tests fail to meet the single point tolerances, or QC/QA test results fail to comply with **SECTION 602**, suspend the production of that mix pending satisfactory results of a pre-production sample. Such suspension will constitute Lot termination.

**f. Additives.** Provide a method for the Engineer to continually monitor the percent of each additive being added.

When more than 25% of the mix is comprised of siliceous virgin aggregates and/or RAP, add anti-strip to the mix. The minimum amount of anti-strip required in the mix is 0.01% for every percent of natural sand and RAP in the mix. Thus, if 25% natural sand and 10% RAP is in a mix, then 0.35% anti-strip by weight of virgin asphalt binder is required in the mix.

If during production, the TSR values (both KDOT and Contractor) exceed 85%, then the Contractor and the DME, working together, may decide on a lower amount of anti-strip.

Provide Warm Mix Asphalt (WMA) additives or processes that comply with **DIVISION 1200**. The Contractor is permitted to use WMA unless otherwise shown on the plans.

For mixes containing Warm Mix Asphalt (WMA) additives, submit for the Engineer's review and approval, the additive or process used, the recommended rate of application, and the temperature ranges for mixing and compaction.

Mixing temperature range is provided by the Asphalt Binder Supplier. When using WMA, the mixing temperature may be reduced no more than 30°F for WMA water foaming processes, and no more than 70°F for WMA chemical and organic additives. The minimum mixing temperature for WMA is 220°F.

### 611.3 CONSTRUCTION REQUIREMENTS

**a. General.** Prepare the road surface according to **subsection 602.4b**.

## 611 - HOT MIX ASPHALT (HMA)-COMMERCIAL GRADE

Use equipment that complies with **DIVISION 150** to produce, haul, spread and compact the HMA-Commercial Grade mixture.

**Lift Thickness.** Except for leveling courses or when shown otherwise in the Contract Documents, **TABLE 602-9** applies. The Engineer may adjust lift thickness to utilize the most efficient method of acquiring specified density and surface quality. The minimum lift thickness for any HMA mixture is 3 times the nominal maximum aggregate size, unless otherwise designated in the Contract Documents or approved by the Engineer.

<b>TABLE 602-9: NOMINAL COMPACTED THICKNESS</b>	
<b>Lift</b>	<b>Maximum Nominal Compacted Thickness</b>
Surface	2 inches
Base	4 inches

Use a minimum of 2 rollers to compact the mixture to the maximum density before the mixture temperature falls below 175°F. When using WMA, achieve the maximum density before the temperature of the WMA falls below 165°F. Do not crush the aggregate. On incidental or miscellaneous work, the Engineer may waive the minimum roller requirement if conditions warrant. Roller marks may be removed with a self-propelled static roller when the pavement surface temperature falls below 175°F or 165°F for WMA, roller marks may be removed from the mat with a self-propelled static steel roller.

**b. Weather Limitations.** Do not place asphalt mixtures on any wet or frozen surface or when weather conditions otherwise prevent the proper handling and finishing of the mixture.

Only place asphalt mixtures when either the ambient air temperature or the road surface temperature is equal to or greater than that shown in **TABLE 611-4**.

<b>TABLE 611-4: ASPHALT PLACEMENT TEMPERATURE LIMITATIONS</b>							
<b>Paving Course</b>	<b>Thickness (inches)</b>	<b>Air Temperature (°F)</b>			<b>Surface Temperature (°F)</b>		
		<b>HMA</b>	<b>WMA Foam</b>	<b>WMA Chem</b>	<b>HMA</b>	<b>WMA Foam</b>	<b>WMA Chem</b>
Surface	All	50	45	40	55	50	45
Subsurface	<1.5	50	45	40	55	50	45
Subsurface	≥1.5 and < 3	40	35	30	45	40	35
Subsurface	≥ 3	30	30	30	35	32	32

**c. Pavement Smoothness.** Evaluate pavement smoothness according to **SECTION 603** and the following:

Excluding side roads, entrances and non-traffic areas, the Engineer may test the completed surface with a 10 foot straightedge, and the maximum allowable surface variation is 3/16 inch in 10 feet. Correct areas that exceed the allowable variation as directed by the Engineer.

HMA Commercial Grade is not eligible for pay adjustments.

### 611.4 MEASUREMENT AND PAYMENT

The Engineer will measure HMA-Commercial Grade and HMA-Commercial Grade (Patching) by the ton.

Payment for "HMA-Commercial Grade (Class\*)" at the contract unit prices is full compensation for the specified work (including emulsified asphalt for tack). Payment for and "HMA-Commercial Grade (Class \*) (Patching)" includes all excavation, compaction of subgrade or subbase if required, disposal of waste material and all material (including emulsified asphalt for tack), all labor, equipment, tools, supplies, incidentals and mobilization necessary to complete the work.

If the gradation test results or air void test results indicate there is non-compliant material, the Engineer will compute and assess either an Aggregate Price Adjustment or an Air Void Price Adjustment that will be an item added to the contract.

(1) Aggregate Price Adjustment. Use **TABLE 611-5**, on each Lot of asphalt mixture represented by non-compliant cold-feed gradation (acceptance) tests:

- Determine the absolute value of the deviation between the acceptance test results (rounded to the nearest 0.01%) and the design virgin aggregate single point for the No. 4, No. 8, No. 30 and the No 200 pay sieves.
- Use the 1 Test Column in **TABLE 611-5** to determine payment for the Lot.
- Use the deviation from the sieve that produces the greatest price adjustment.

**611 - HOT MIX ASPHALT (HMA)-COMMERCIAL GRADE**

<b>TABLE 611-5: SCHEDULE OF ADJUSTED PAYMENT FOR ASPHALT MIXES</b>					
		<b>Accumulated Deviation of the Acceptance Tests from the Design Job-Mix Single Point</b>			
<b>Tolerance</b>	<b>Pay Factor</b>	<b>1 Test</b>	<b>2 Tests</b>	<b>3 Tests</b>	<b>4 Tests</b>
± 7	1.00	0.00 - 7.00	0.00 - 9.00	0.00 - 12.12	0.00 - 14.00
	0.98	7.01 - 7.50	9.91 - 10.60	12.13 - 12.99	14.01 - 15.00
	0.95	7.51 - 8.00	10.61 - 11.32	13.00 - 13.86	15.01 - 16.00
	0.92*	8.01 - 8.50	11.33 - 12.02	13.87 - 14.73	16.01 - 17.00
	0.88*	over 8.50	over 12.02	over 14.73	over 17.00
± 6	1.00	0.00 - 6.00	0.00 - 8.48	0.00 - 10.38	0.00 - 12.00
	0.98	6.01 - 6.50	8.49 - 9.20	10.39 - 11.25	12.01 - 13.00
	0.95	6.51 - 7.00	9.21 - 9.90	11.26 - 12.12	13.01 - 14.00
	0.92*	7.01 - 7.50	9.91 - 10.60	12.13 - 12.99	14.01 - 15.00
	0.88*	over 7.50	over 10.60	over 12.99	over 15.00
± 5	1.00	0.00 - 5.00	0.00 - 7.08	0.00 - 8.61	0.00 - 10.00
	0.98	5.01 - 5.50	7.09 - 7.78	8.62 - 9.54	10.01 - 11.00
	0.95	5.51 - 6.00	7.79 - 8.48	9.55 - 10.38	11.01 - 12.00
	0.92*	6.01 - 6.50	8.49 - 9.20	10.39 - 11.25	12.01 - 13.00
	0.88*	over 6.50	over 9.20	over 11.25	over 13.00
± 4	1.00	0.00 - 4.00	0.00 - 5.66	0.00 - 6.93	0.00 - 8.00
	0.98	4.01 - 4.50	5.67 - 6.36	6.94 - 7.80	8.01 - 9.00
	0.95	4.51 - 5.00	6.37 - 7.08	7.81 - 8.67	9.01 - 10.00
	0.92*	5.01 - 5.50	7.09 - 7.78	8.68 - 9.54	10.01 - 11.00
	0.88*	over 5.50	over 7.78	over 9.54	over 11.00
± 3	1.00	0.00 - 3.00	0.00 - 4.24	0.00 - 5.19	0.00 - 6.00
	0.98	3.01 - 3.20	4.25 - 4.52	5.20 - 5.55	6.01 - 6.40
	0.95	3.21 - 3.40	4.53 - 4.80	5.56 - 5.97	6.41 - 6.80
	0.92*	3.41 - 3.80	4.81 - 5.38	5.98 - 6.57	6.81 - 7.60
	0.88*	over 3.80	over 5.38	over 6.57	over 7.60
± 2.5	1.00	0.00 - 2.50	0.00 - 3.54	0.00 - 4.32	0.00 - 5.00
	0.98	2.51 - 2.70	3.55 - 3.82	4.33 - 4.68	5.01 - 5.40
	0.95	2.71 - 2.90	3.83 - 4.10	4.69 - 5.01	5.41 - 5.80
	0.92*	2.91 - 3.30	4.11 - 4.66	5.02 - 5.73	5.81 - 6.60
	0.88*	over 3.30	over 4.66	over 5.73	over 6.60
± 2	1.00	0.00 - 2.20	0.00 - 3.12	0.00 - 3.81	0.00 - 4.40
	0.95	2.21 - 2.40	3.13 - 3.40	3.82 - 4.17	4.41 - 4.80
	0.92*	2.41 - 2.75	3.41 - 3.88	4.18 - 4.77	4.81 - 5.56
	0.88*	over 2.75	over 3.88	over 4.77	over 5.56

\*If approved by the Engineer, the Contractor may accept the indicated partial pay. KDOT may require removal and replacement at no additional cost. At any time, the Contractor may remove and replace at no cost to KDOT.

(2) Air Void Price Adjustment. The Engineer will assess an Air Void Price Adjustment (negative price adjustment only), as outlined in **SECTION 602**, on the asphalt material (taken from each QC/QA Lot) represented by non-compliant QC/QA (acceptance) tests.

## 612 - MILLING

### SECTION 612

#### MILLING

##### 612.1 DESCRIPTION

Remove the existing surface to the depth and limits shown in the Contract Documents or established by the Engineer. Load and stockpile the milled material, when required.

Provide transitions at transverse joints and raised structures to create a smooth longitudinal riding surface before opening the milled surface to traffic.

Remove transitions prior to resurfacing.

##### BID ITEM

Milling

\* Unit of Measurement Shown in the Contract Documents

##### UNITS

\*

##### 612.2 MATERIALS – None specified.

##### 612.3 CONSTRUCTION REQUIREMENTS

Remove the existing surface to the required grade line as established by the Engineer. Use equipment that is automatically controlled with regard to grade and slope. Operate the automatic grade and slope control from a traveling stringline, a minimum of 30 feet long, attached to the milling machine and operating parallel to the line of travel.

Extend the cross slope of the pavement by milling across the shoulder to the point where this line intersects the existing shoulder surface or to the edge of the shoulder, whichever is less, unless shown otherwise in the Contract Documents or directed by the Engineer. When shoulders are to be milled (daylighted out), mill them the same day as the adjacent traveled way pavement is milled.

When milling multiple passes, mill so the longitudinal joint between passes is flush.

When milling asphalt down to an existing concrete pavement, keep the final milling operation a maximum of 2 miles ahead of the laydown operation, unless approved otherwise by the Engineer.

Do not track the milling machine across span bridges if the operating weight of the machine exceeds 80,000 pounds.

Limit the operating weight of the milling machine to 80,000 pounds when removing existing asphalt material from, or performing machine preparation on a bridge deck.

If the milled area will be opened to traffic prior to resurfacing, perform the following:

- At transverse joints, either feather transitions between milled and unmilled surfaces by milling or placing a wedge of hot mix asphalt (no steeper than 1 vertical, 24 horizontal), for the entire width of the transverse joint.
- After removal of existing material around manholes, utility valves inlets and other appurtenances, place a temporary wedge around the appurtenance (no steeper than 1 vertical, 12 horizontal).
- Use hot mix asphalt or other approved material of a thickness and design that the material remains intact while under traffic.
- Remove transitions prior to resurfacing.

Do not open the milled area to traffic unless all transverse joints, manholes, utility valves, inlets and other appurtenances have wedges in place to provide for a smooth longitudinal riding surface.

##### 612.4 MEASUREMENT AND PAYMENT

When milling is a bid item in the contract, the Engineer will measure milling as shown in the Contract Documents. This shall include the removal, hauling, if required, and stockpiling of existing surface.

When shown by the Station, the Engineer will measure the Station along the centerline of the lanes, regardless of the pavement width.

When shown by the square yard, the Engineer will measure the square yards of surface milled.

When shown by the ton, the Engineer will measure the tons of material milled.

Payment for "Milling" at the contract unit price is full compensation for the specified work.

613 – ULTRATHIN BONDED ASPHALT SURFACE

SECTION 613

ULTRATHIN BONDED ASPHALT SURFACE

613.1 DESCRIPTION

Construct the ultrathin bonded asphalt surface (UBAS) as designated in the Contract Documents.

**BID ITEMS**

HMA Surface (Ultrathin Bonded) (\*) (\*\*)  
Emulsified Asphalt (Emulsion Bonding Liquid)  
Quality Control Testing (HMA)

**UNITS**

Ton  
Ton  
Ton

\* Type of mix gradation  
\*\* Grade of Asphalt Binder

613.2 CONTRACTOR QUALITY CONTROL REQUIREMENTS

**a. General.** Provide qualified personnel and sufficient equipment complying with the requirements listed in Part V to conduct quality control testing that complies with Appendix B - Sampling and Testing Frequency Chart for Asphalt Construction Items for Quality Control/Quality Assurance Projects.

Allow the Engineer access to the Contractor’s laboratory to observe testing procedures, calculations, test documentation and plotting of test results.

Calibrate and correlate the testing equipment with prescribed procedures, and conduct tests in compliance with specified testing procedures as listed in Section 5.2.7- Contractor’s Quality Control Plan, Part V.

Store and retain the most recent 2 lots per mix designation of quality control samples for KDOT. KDOT will retain the most recent 2 lots per mix designation gyratory compacted samples and the remaining material not previously used for testing (back half of sample). Do not retain more than the previous 3 lots per mix designation of quality control or verification samples. When the hot mix plant shuts down for the winter, discard the samples after 7 days.

Maintain control charts on an ongoing basis.

At the completion of the project, all documentation becomes the property of KDOT.

Provide the following test data to the KDOT Project Representative:

- Copies of all test results and control charts on a weekly basis, representing the prior week’s production;
- Copies of the quality control summary sheet on a daily basis. Include, as a minimum, mix gradation, binder content, theoretical maximum specific gravity ( $G_{mm}$ ) and film thickness; and
- Copies of all failing test results (based on a moving average of 3 tests, when appropriate).

**b. Quality Control Plan (QCP).** At the pre-construction conference, submit to the Engineer for approval, a QCP as outlined in Section 5.2.7 – Contractor’s Quality Control Plan, Part V. Follow Appendix A of the Contractor’s Quality Control Plan in Part V as a general guideline. The Contractor’s laboratory and equipment will be inspected and approved as outlined in Section 5.2.7 - Contractor’s Quality Control Plan, Part V.

Include a listing of the names and phone numbers of individuals and alternates responsible for quality control administration and inspection. On the Contractor’s organizational chart, show the specified lines of authority relating both to mix design and quality control operations during production. Post the organizational chart in the Contractor’s test facility.

Provide a quality control organization or private testing firm having personnel certified according to the Policy and Procedure Manual for the Certified Inspection and Testing (CIT) Training Program. The testing for this type of construction will require personnel certified in Aggregate Field Tester (AGF), Aggregate Lab Technician, Profilograph (PO), and Superpave Field (SF) classifications.

Only persons certified in the appropriate classifications covering the specific tests required shall perform such testing. At the beginning of the project, provide the Engineer with the list of certified technicians and alternates, phone numbers and tests/inspection they will be performing. As personnel changes and certifications may expire, continue to provide the Engineer with an accurate list.

## 613 – ULTRATHIN BONDED ASPHALT SURFACE

Provide an organizational chart showing the specified lines of authority relating to both mix design and quality control operations during production. Identify the company official acting as liaison with KDOT, and the Certified Technician who will direct inspection and testing. Post the chart in the test facility.

**c. Required Duties of Certified Technicians.** Be available on the project site whenever UBAS is being produced and being placed on the project site. Perform and utilize quality control tests and other quality control practices to assure that delivered materials and proportioning meet the requirements of the mix designs.

Periodically inspect all equipment utilized in transporting, proportioning, mixing, placing, and compacting to assure it is operating properly and that placement and compaction comply with the contract requirements.

**d. Contractor's Testing Facilities.** Describe the testing facility and its accreditation in the QCP.

Locate the testing facility either at the plant site or at the project. Obtain approval of the testing facilities and location from the DME before the commencement of mixture production.

Provide suitable space for the required testing equipment. Also, equip the testing facility with these items for the exclusive use of the testing facility's quality control personnel and the Engineer:

A telephone with a private line for the exclusive use of the testing facility's quality control personnel; and

A copying machine for use by the Contractor's personnel and the Engineer.

Provide Broadband internet connection (for 1 computer). If the Engineer determines that broadband internet service is not available, provide a fax machine, at no additional cost.

An air conditioner capable of maintaining a temperature below 77°F in the main part of the Field Office and Laboratory.

Locate the KDOT field laboratory near the Contractor's testing facility and have it fully functional 2 working days before placement of the pre-production mix.

**e. Documentation.** Include in the QCP procedures, charts and forms to be used to provide the required documentation.

Record all original documentation in a bound field book or other KDOT approved bound record and turn over to KDOT at the end of the project.

At all times, have complete records of all inspections and tests available on site for the Engineer. All records documenting the Contractor's quality control inspections and tests become the property of KDOT upon completion of the work.

Indicate the nature and number of observations made, the number and type of deficiencies found, the quantities approved and rejected, and the corrective action taken in the records. Examples of quality control forms and charts are available in Part V, or Contractors may design their own. Documentation procedures are subject to approval by the Engineer before the start of the work and to compliance checks during the progress of the work.

Maintain control charts on an ongoing basis.

Provide the following test data to the KDOT Project Representative:

- Copies of all test results and control charts on a weekly basis, representing the prior week's production;
- Copies of the quality control summary sheet on a daily basis. Include, as a minimum, mix gradation, binder content, theoretical maximum specific gravity ( $G_{mm}$ ) and film thickness; and
- Copies of all failing test results (based on a moving average of 3 tests, when appropriate). Include all applicable sieves, binder content and film thickness.

**f. Testing Requirements.** In the QCP, identify test methods, procedures and equipment proposed for use. Use standard KDOT test methods and properly calibrated measuring and testing equipment as outlined in Part V. Detail any alternative sampling method, procedure or inspection equipment proposed to be used. Such alternatives are subject to review and approval by the DME.

Take all samples for tests and perform in-place tests at random locations, selected according to the Contractor's QCP and at the rates specified in the Sampling and Testing Frequency Chart for UBAS for Quality Control/Quality Assurance Projects in Appendix B, Part V.

**g. Pre-Production Testing Requirements.**

(1) The Engineer will observe the Contractor obtaining and splitting the pre-production test section samples into 3 representative portions. Each sample set shall consist of enough material for  $G_{mm}$  and ignition burnoff testing.

(2) Determine  $G_{mm}$ , perform ignition burnoff, evaluate the mix gradation and complete calculations.

## 613 – ULTRATHIN BONDED ASPHALT SURFACE

(3) Provide the KDOT Field Representative with the 2nd sample set. The KDOT Field Representative will determine  $G_{mm}$ , perform ignition burnoff, evaluate the mix gradation and complete calculations.

(4) Retain or provide the 3rd sample set to the KDOT Field or District Materials Representative.

(5) The results of the testing will be compared. If Contractor and KDOT field laboratory test results do not compare favorably, the District Materials Laboratory will test their  $\frac{1}{3}$  of the sample. KDOT personnel will determine  $G_{mm}$ , perform ignition burnoff and complete calculations.

If results are not acceptable to either party, repeat the above steps in **subsections 613.2g.(1) through (4)** for the Contractor's Field Laboratory, KDOT's Field Laboratory, and KDOT's District Laboratory until the issues may be resolved satisfactorily by all parties.

### **h. Lot 1 Testing Requirements.**

(1) Sequence of Sampling. KDOT field personnel will determine the random truckload for the Contractor for sublots A, B, C and D, and the KDOT verification test.

The verification sample will be sampled and tested by KDOT field personnel. The verification sample shall be randomly taken within the lot and shall not be from the same truckload as selected for the Contractor's subplot samples A, B, C or D.

Obtain sampling using KT-25 procedure C.1 Plant Discharge or C.2 Truck Bed.

KDOT field personnel will:

- not supply the Contractor the identity of the truckload to be sampled ahead of time;
- notify the Contractor's laboratory of which truck to sample after the aggregate has left the cold feeds, and before the truck is finished loading; and
- determine whether the split sample will be taken from subplot A or B and notify the Contractor.

(2) Split Samples. The Contractor shall:

- obtain a sample large enough to split 3 ways for testing;
- retain and test  $\frac{1}{3}$  of the sample;
- supply  $\frac{1}{3}$  of the sample to the KDOT field laboratory for testing; and
- retain or supply  $\frac{1}{3}$  of the sample for the KDOT District Materials Laboratory.

(3) Results. At a minimum, compare the KDOT Field Laboratory's and the Contractor's  $G_{mm}$ , binder content, and film thickness results. The acceptable difference for the  $G_{mm}$  results is 0.019. If the results exceed this difference, take an additional split sample in Lot 1 from subplot C or D, as time permits.

If Contractor and KDOT field laboratory test results do not compare favorably, KDOT and the Contractor will investigate the differences in test results together and take appropriate action. The Contractor's test results will be used for quality control. KDOT Field Laboratory test results and District Materials Laboratory test results will be reported as "information only" samples.

### **i. Testing Requirements for Lots 2 and Greater.**

(1) Take all samples for tests randomly as designated in the approved QCP at the rates specified in Appendix B - Sampling and Testing Frequency Chart, Part V.

Provide the Engineer with the random locations before obtaining the sample. The Engineer reserves the right to generate the random locations. If the Engineer generates the random locations, the Contractor will be notified of which truck to sample after the aggregate has left the cold feeds, and before the truck is finished loading.

(2) Conduct the tests for mixture properties, aggregate gradation and binder content on representative portions of the HMA, quartered from the larger sample of HMA. Take a random sample weighing a minimum of 55 pounds using a method to retain heat to facilitate sample quartering procedures.

(3) Record and document all test results and calculations on data sheets provided by KDOT. Record specific test results on a daily summary sheet provided by KDOT to facilitate the computation of moving test averages. Base moving averages on 3 consecutive test results. Calculations are to be based on the precision displayed on the data sheets. Use "precision displayed" when calculating within Excel. Appendix B - Sampling and Testing Frequency Chart, Part V shows the accuracy to "record to" for the tests listed. Include a description of quality control actions taken (adjustment of cold feed percentages, changes in Job Mix Formulas (JMF), etc.) in the Daily Quality Control Summary Sheet. In addition, post and keep current quality control charts, showing both individual test results and moving average values. As a minimum, plot the single test values on KDOT approved control charts for the mix characteristics shown in **TABLE 613-5**.

(4) If the Contractor and Engineer agree, the procedures shown for sampling, testing and evaluation of Lot



## 613 – ULTRATHIN BONDED ASPHALT SURFACE

1 in **subsection 613.2h**, may be used for any other Lot produced on the project.

**j. Corrective Action.** In the QCP, identify procedures for notifying the Engineer when corrective measures must be implemented, and for halting production.

**k. Non-Conforming Materials.** In the QCP, specifically address how non-conforming materials will be controlled and identified. Establish and maintain an effective and positive system for controlling non-complying material, including procedures for its identification, isolation and disposition. Reclaim or rework non-complying materials according to procedures acceptable to the Engineer. This could include removal and replacement of in-place pavement.

Positively identify all non-conforming materials and products to prevent use, shipment and intermingling with complying materials and products. Provide holding areas, mutually agreeable to the Engineer and Contractor.

### 613.3 MATERIALS

**a. Asphalt Binder.** Provide Asphalt Binder that complies with **DIVISION 1200**. Post a legible copy of the latest bill of lading for the Asphalt Binder in the Contractor's Field Lab. Use the mixing and compaction temperatures shown on the bill of lading; however, the maximum mixing or compaction temperature is 340°F, unless otherwise approved by the Field Materials Engineer. Notify the Engineer if the mixing or compaction temperature changes.

Provide Emulsion Bonding Liquid (EBL) that complies with **DIVISION 1200**.

**b. Reclaimed Asphalt Pavement (RAP) and Recycled Asphalt Shingles (RAS).** Do not use RAP or RAS in the UBAS.

**c. Aggregates.** Provide aggregates that comply with **SECTION 1103**.

**d. Combined Aggregates.** Provide combined aggregates for the mixes required in the Contract Documents as shown in **TABLE 613-1**.

Mixes may use any combination (except as noted below) of aggregate and mineral filler supplements complying with the applicable requirements in **TABLES 1103-1** and **1103-2**. When coarse aggregates are blended from 1 or more sources, or if more than 1 type, each source or type shall meet the coarse aggregate properties (CAA, LA Abrasion, and micro-deval) in **TABLE 1103-3**.

The minimum Uncompacted Void Content of the Fine Aggregate "U" Value, of the combined aggregate is 45%.

The minimum sand equivalency (SE) of the combined aggregates is 45%.

Provide materials with less than 0.5% moisture in the final mixture.

The maximum quantity of crushed steel slag used in the mix is 50% of the total aggregate weight.

No natural sand will be used in the UBAS.

Traveled way mixes shall include:

- a minimum of 40% primary aggregate based on total aggregate weight;
- a minimum of 50% of the plus No. 4 mesh sieve material in the mixture shall be from the primary aggregate;
- a minimum of 45% of the plus No. 8 mesh sieve material in the mixture shall be from the primary aggregate; and
- Primary aggregates are designated as CS-1 (excluding limestone), CS-2 (excluding limestone), CG, CH-1 and CSSL as described in **subsection 1103.2a.(1)**. Primary aggregate requirements do not apply to the mixture on the shoulder.

**e. Contractor Trial Mix Design.** A minimum of 10 working days before the start of UBAS production, submit in writing to the DME for review and approval, a proposed JMF for each combination of aggregates. For each JMF submitted, include test data to demonstrate that mixtures complying with each proposed JMF shall have properties specified in **TABLE 613-1** for the designated mix type at the Recommended Percent Asphalt ( $P_{br}$ ). Submit the proposed JMF on forms provided by KDOT. Submit the worksheets used in the design process to include at a minimum the individual coarse aggregate properties listed in **TABLE 1103-3**, the fine aggregate

## 613 – ULTRATHIN BONDED ASPHALT SURFACE

properties listed in **TABLE 1103-4**, and the mix properties listed in **TABLE 613-2**. Contact the DME to determine if additional material is needed for additional design checks.

For each aggregate used in the mix design, determine the specific gravity using KT-6. This may be accomplished while the project is being constructed or anytime during the 12 months preceding the start of construction on a project. If construction has not yet begun, notify the DME 5 working days prior to obtaining the material for the specific gravity test so that companion samples may be obtained at the same time. If construction has already begun on the project, then determine the specific gravity values of the individual aggregates before 10,000 tons of HMA is produced. Provide the test results to the DME within 14 days of sampling the material. If the producer of the aggregate has been required to submit material to KDOT for a new Official Quality test report since the time the Contractor ran the specific gravity tests, then perform KT-6 on the aggregate currently produced. Do not use the specific gravity values obtained from these tests in the mix design calculations for current projects unless mutually agreeable to both parties. Use the information, as soon as it becomes available, as part of the process to verify and update the “Monthly Hot Mix Aggregate Specific Gravity Values” posted on KDOT’s Internet site.

<b>TABLE 613-1: COMBINE AGGREGATE REQUIREMENTS FOR ULTRATHIN BONDED ASPHALT SURFACE*</b>											
<b>Mix Designation / Nom Thickness</b>	<b>Percent Retained – Square Mesh Sieves</b>										<b>Asphalt Content (%)</b>
	<b>¾"</b>	<b>½"</b>	<b>⅜"</b>	<b>No. 4</b>	<b>No. 8</b>	<b>No. 16</b>	<b>No. 30</b>	<b>No. 50</b>	<b>No. 100</b>	<b>No. 200</b>	
Type A - ⅝"		0	0-7	45-60	68-78	75-85	82-90	87-92	90-94	94.0-96.0	5.0 to 6.2
Type B - ⅝"	0	0-7	0-25	62-75	73-83	77-85	82-90	87-92	90-94	94.0-96.0	4.8 to 6.2
Type C - ⅝"	0	0-25	20-50	62-75	73-83	77-85	82-90	87-92	90-94	94.0-96.0	4.6 to 6.2

\*For flat and elongated particles in the combined coarse aggregate, use the ratio of 3:1 in lieu of 5:1 shown in KT-59. Do not exceed 25% for the total sample.

<b>TABLE 613-2: MIX PROPERTIES</b>		
<b>Property</b>	<b>Test Method</b>	<b>Limits</b>
Total Amine Value of Antistrip Agent, (mg/g of KOH, min) <sup>a</sup>	ASTM D2074	500
Design Film Thickness (µm, min.)	KDOT Construction Manual	9.0 <sup>b</sup>
Drain Down (% max.)	KT-63	0.10
Gyratory Compacted Revolutions, Ndes	KT-58	100 <sup>c</sup>
Emulsion Bonding Liquid (EBL),(gal/sy)	Equation 1	(0.20 ± 0.07) <sup>d</sup>
<p>a – The asphalt binder used in the mix will contain a minimum of 0.25% of an amine based antistripping agent by weight of the asphalt binder.</p> <p>b – Calculate using the film thickness equation in Section 5.10.4-Calcs for Marshall Mix Design of Bituminous Mixtures, Part V.</p> <p>c – Compact gyratory specimen to 100 gyrations. Calculate the percent air voids using KT-15, Procedure IV.</p> <p>d – Calculate the target EBL Shot Rate (S<sub>ebi</sub> (gal.sy)), using Equation 1; however, the value must be within the limits in this table.</p> <p>Equation 1:      <math>S_{ebi} = 3.93 * P_s * \frac{(V_a + MF)}{100}</math></p> <p>The particle size (P<sub>s</sub>), and the mix factor (MF) are based on the mix designation as shown in the <b>TABLE 613-3</b>.</p>		

<b>TABLE 613-3: VARIABLES IN EBL SHOT RATE EQUATION</b>		
<b>Mix Designation</b>	<b>Particle Size (Ps)</b>	<b>Mix Factor (MF)</b>
Type A	0.250	3.2
Type B	0.375	3.2
Type C	0.500	3.2

**613 – ULTRATHIN BONDED ASPHALT SURFACE**

Consider adjusting the EBL spray rate based on the condition of the existing surface as listed in the **TABLE 613-4**. Consult the supplier of the EBL to obtain the recommended adjustment to the spray rate.

<b>TABLE 613-4: EBL ADJUSTMENT CONSIDERATIONS</b>		
<b>Existing Pavement Type</b>	<b>Condition</b>	<b>Adjustment Rate (gal/sy)</b>
PCCP	Smooth	0.00
	Textured	+0.02 to +0.04
HMA	Flushed	-0.02 to -0.04
	New	0.00
	Matte and OGFC	+0.02
	Dry	+0.03
	Milled	+0.02 to +0.04
Surface Recycle & Cold Recycle	Flushed	-0.02 to -0.04
	Black	+0.02
	Dry	+0.03
Chip Seal	Flushed	-0.02 to -0.04
	Black	+0.02
	Dry	+0.03

**613.4 CONSTRUCTION REQUIREMENTS**

**a. Plant Operation.** Adjust all plant operations to operate continuously.

(1) Preparation of the Asphalt Binder. Heat the asphalt binder to within a range as specified in **SECTION 601**. When heating the asphalt binder to the specified temperature, avoid local overheating. At all times, provide a continuous supply of the asphalt binder to the mixer at a uniform temperature. Asphalt binder received from the refinery at temperatures less than 375°F may be used as received, if the requirements regarding the reheating of asphalt binder in **SECTION 601** are met.

(a) Commingling of Asphalt Binders. Do not add or commingle asphalt binders from 2 or more sources into a storage tank. If this occurs, the contents of the storage tank are considered contaminated. Do not use the contents of the storage tank on the project, except as follows: It is permissible, at the Contractor’s option, to thoroughly mix the contents of the tank and request sampling of the mixture. Submit the sample to the MRC for testing. Do not use the asphalt binder until approved, and when needed, a new mix design evaluation is completed.

(b) Asphalt Binder Sources. Before changing asphalt binder sources on a project, obtain approval from the DME. A new JMF may be required.

(c) Anti-Strip Additives. If liquid anti-strip additives are added at the Contractor’s plant, install a “totalizer” to monitor the quantity of anti-strip additive being added. The Engineer may approve alternative methods for including anti-strip additives in a batch plant. If added at the plant, the anti-strip will be added in line with the asphalt binder as it is being transferred from the transit unit to the asphalt binder storage tank. Provide a method for the Engineer to monitor the percent of additive being added.

(2) Preparation of Mineral Aggregate. When the mineral aggregate is composed of 2 or more ingredients, combine as shown in the approved JMF.

Temperature Requirements. Dry the aggregate for the mixture and heat to a temperature to obtain an asphalt-aggregate mixture temperature immediately after mixing within the 75 to 150 second Saybolt viscosity range of the asphalt binder used. Obtain the temperature for this viscosity range from the MRC or the Asphalt Binder Producer. No mixing or compaction temperatures are to exceed 340°F without approval from the Field Materials Engineer. The minimum temperature may be revised by the DME provided it is demonstrated that satisfactory results may be obtained at a lower temperature. In such event, deliver the HMA to the paver at a temperature sufficient to allow the material to be satisfactorily placed and compacted to the specified density and surface tolerance requirements.

(3) Preparation of HMA. Introduce asphalt binder into the prepared aggregate in the proportionate amount determined by the  $P_{br}$  in the JMF.

## 613 – ULTRATHIN BONDED ASPHALT SURFACE

(a) Basis of Rejection. HMA will be rejected if the aggregate, as it is discharged from the drum or the pugmill, contains sufficient moisture to cause foaming of the mixture, or if the temperature of the aggregate is such that the asphalt-aggregate mixture temperature is outside the range specified in **SECTION 601**.

(b) Mixing Time. Operate drum mixers at a rate to provide uniform aggregate coating in a continuous operation. For batch and continuous type plants, the minimum wet mixing time is 40 seconds. In all cases, mix a sufficient time to produce a uniform mixture in which all the aggregate particles are thoroughly coated. On batch plants, begin the timing at the start of the asphalt binder introduction into the pugmill, and end upon the opening of the discharge gate. For continuous flow plants, mixing time in seconds shall equal:

[pugmill dead capacity in pounds] divided by [pugmill output in pounds per second].

(c) Manufacturer's Specifications. Operate all drying, pumping and mixing equipment within the limits specified by the manufacturer, unless it can be demonstrated to the satisfaction of the Engineer that such limits may be exceeded without detriment to the HMA.

(d) Batch Operation. Coordinate HMA batchers (Gob Hoppers) with the plant production rate at all times so the hopper is more than  $\frac{3}{4}$  full before the gates open, and the gates close before material can drop through the gob hopper directly into the surge bin, weigh hopper or truck.

(e) Wasted Material. Wasted material is not measured for pay.

If after an interruption of production, the drum-mixer contains cold, uncoated or otherwise unsuitable material, waste material through a diversion chute. In a continuous or batch plant drier, waste unsuitable material through the pugmill.

At the end of a production run, waste any segregated material in the cone of the storage bin.

(4) End of Day Quantities. At the end of each day of production, provide the Engineer with a document signed by the Plant Foreman or the Project Manager listing the dry weight of each aggregate and mineral filler; the tons of asphalt binder, and the tons of anti-strip agent used for the project during the day. The dry weight is the tons of the material less the water content.

### **b. Road Surface Preparation.**

(1) Preparation of an Existing Asphalt Pavement. Clean the surface to remove all foreign material and broom to remove dust. Excavate areas shown in the Contract Documents to be patched to a depth directed by the Engineer. Fill with HMA and compact.

(2) Preparation of an Existing Concrete or Brick Pavement. Clean all foreign material and broom to remove dust. Clean and fill cracks and joints, and construct surface leveling as shown in the Contract Documents.

**c. Weighing Operations.** See **subsection 109.1** for details regarding weighing operations.

**d. Hauling Operations.** Schedule operations to minimize hauling over a surface course.

Deliver HMA to the paver at a temperature sufficient to allow the material to be placed and compacted to the specified density and surface tolerance.

### **e. Paving Operations.**

(1) Equipment Use a transfer device between the haul units and the paver to assist in maintaining continuous placement. Use equipment such as a shuttle buggy, material transfer vehicle or mobile conveyor. (The material will not be deposited on the roadway and a pick-up device used to transfer the material to the paver.)

Use a self-priming paver, designed and built for applying the UBAS and approved by the Engineer.

Use a paver with the following requirements:

- with a receiving hopper, feed conveyor, asphalt emulsion storage tank, a system for measuring the EBL volume applied, a spray bar, and a heated, variable width, vibratory screed;
- capable of spraying the EBL, applying the hot mix surface course and leveling the surface of the mat in one pass;
- capable of placing the hot mix surface course within 5 seconds after the application of the EBL;
- capable of paving at a controlled speed from 30-100 feet/minute;
- equipped so no wheel or other part of the paving machine is in contact with the EBL before the hot mix surface course is applied; and

## 613 – ULTRATHIN BONDED ASPHALT SURFACE

- equip the screed with the ability to crown the pavement at the center and have vertically adjusted extensions to accommodate the desired pavement profile.

The Engineer will check the pavement for longitudinal streaks and other irregularities. Make every effort to prevent or correct any irregularities in the pavement, such as changing pavers or using different and additional equipment.

Do not raise (dump) the wings of the paver receiving hopper at any time during the paving operation.

(2) Application: Spray the EBL by a metered mechanical pressure spray bar at the temperature specified in **TABLE 601-1**, or as recommended by the EBL supplier. Use a sprayer that accurately and continuously monitors the rate of spray and provides a uniform application across the entire width to be overlaid. The Engineer may make adjustments to the spray rate based upon the existing pavement surface conditions and the recommendations of the EBL supplier.

Apply the UBAS at a temperature of 290-330°F and spread over the EBL immediately after the application of the EBL. Place the UBAS over the full width of the EBL with a heated vibratory screed. Adjust the screed and its extensions to eliminate variances in surface texture caused by density segregation. Operate the paver as continuous as possible to reduce the possibility of screed indentations in the finished mat.

The target application rate of the UBAS will be stated in the Contract Documents. Use a field application rate as necessary to minimize fracturing of the top size aggregate by the screed. The Engineer will determine the acceptable extent of fracturing at the edge of the paving for tapering purposes.

The finished asphalt surface shall be free of oversized material. The Engineer will determine the extent of the oversized material in the UBAS. Take immediate corrective action to eliminate the source. If the source of the oversized material is determined to be a stockpile or a process of plant operations, cease production until corrective actions are complete.

Spread the UBAS without tearing the surface. Strike a finish that is smooth, free of segregation, true to cross section, uniform in density and texture and free from surface irregularities. If the pavement does not comply with all of these requirements, plant production and paving will be suspended until the deficiency is corrected.

(3) Compaction: Roll the UBAS with a minimum of 1 pass and a maximum of 3 passes with 2-axle tandem steel rollers having a minimum weight of 10 tons, before the material temperature has fallen below 195°F. The Engineer will determine the number of passes necessary based on appearance of the rolled material. Do not allow the roller or rollers to remain stationary on the freshly placed UBAS. Perform rolling immediately following the placement of the UBAS with approved asphalt rollers. Supply adequate roller units so the rolling will be accomplished promptly following the placement of the material. A release agent (added to the water system) may be required to prevent adhesion of the fresh mix to the roller drum and wheels. Normally, perform rolling in the static mode. Do not excessively roll the driving lanes, to the extent of aggregate degradation. The Engineer will determine the acceptable extent of fracturing at the edge of the pavement from the rolling operation. Do not open the new pavement to traffic or allow any roller to sit idle on the pavement until the rolling operation is complete and the material has cooled below 160°F.

Damaged Areas: Replace any defective areas, as determined by the Engineer, at no additional cost to KDOT.

(4) Construction Joints.

- Transverse Construction Joints. Use a method of making transverse construction joints which provide a thorough and continuous bond and provide an acceptable surface texture. Do not vary the surface elevation more than 3/16 inch in 10 feet, when tested longitudinally across the joint. When required, repair the joints or paving operations will be suspended.
- Longitudinal Joints. Construct well bonded and sealed longitudinal joints to obtain maximum compaction at the joint.

(5) Adjustment of Manholes (Set Price). When required, this work will be performed and paid for under **SECTION 816**.

**f. Maintenance of Traffic.** Maintain traffic according to **DIVISION 800** and the following:

Maintain one-way traffic, and restrict traffic speeds to 20 miles per hour in the vicinity of workers, unless otherwise designated. Use pilot cars to lead traffic through the area of paving and rolling operations, and if directed, through a curing area. The use of flaggers is allowed through patching operations, unless the patching area or distance between flaggers exceeds ½ mile, in which case the use of a pilot car shall be required. On overlay projects with 2 lanes or more in each direction for traffic use, the Engineer may waive the pilot car requirements.

**613 – ULTRATHIN BONDED ASPHALT SURFACE**

Station one flagger ahead of the application of the tack coat and one flagger ahead of the area being protected from traffic. Take adequate protection for traffic on side roads approaching the tack area.

**g. Treatment of Adjacent Areas.** Pave sideroads, entrances and turnouts for mailboxes as shown in the Contract Documents. Overlay all widening areas designated in the Contract Documents or ordered by the Engineer.

**h. Pavement Smoothness.** Evaluate pavement smoothness according to **SECTION 603**.

**613.5 PROCESS CONTROL**

**a. General.** Establish gradation limits and proportions for each individual aggregate and mineral filler. Specify the limits and proportions such that the material produced complies with the applicable requirements of the designated mix type. The Contractor is responsible for all process control operations including testing. At no time will KDOT’s representative issue instructions to the Contractor or producer as to setting of dials, gauges, scales and meters. KDOT will collect and test verification samples and assurance samples and inspect the Contractor’s quality control operations.

**b. JMF Adjustments.** Produce a mixture of uniform composition closely complying with approved design JMF to obtain the specified properties when compacted. If, during production, results from quality control tests demonstrate a need to make adjustments to the mix design, then make adjustments to the design JMF single point gradation and binder content to achieve the specified properties. The JMF adjustments shall produce a mix that complies with **TABLE 613-1** for the specified mix designation. When necessary, adjust on a subplot basis. Report the new JMF to KDOT’s field representative and the DME before making such changes, and submit a new mix design for review and approval if required by the DME.

**c. Specification Working Ranges.** Establish acceptable limits for field test results by applying the tolerances shown in **TABLE 613-5** to the JMF or adjusted JMF for binder content. Establish acceptable limits for the other listed mix characteristics by applying the tolerances shown in **TABLE 613-5** to the requirements of **TABLE 613-1**.

<b>TABLE 613-5: SPECIFICATION WORKING RANGES (QC/QA)</b>			
<b>Mix Characteristic</b>	<b>Tolerance from JMF and Specification Limits</b>		
	<b>Single Test Value</b>	<b>Plot</b>	<b>3 Point Moving Average Value</b>
Binder Content (Maximum deviation from JMF)	±0.3%	*	±0.3%
Film Thickness	n/a	*	zero tolerance
Gradation**	n/a	*	zero tolerance
Course Aggregate Angularity (CAA)	zero tolerance		n/a
Fine Aggregate Uncompacted Voids (FAA)	zero tolerance		n/a
Sand Equivalent	zero tolerance		n/a
*Values to plot. In addition, plot the Gmm values. For gradations, as a minimum, plot the No. 4, 8, 30 and 200 sieves.			
**The maximum deviation for UBAS from the JMF for the sieves with a ± tolerance shall be as listed in <b>TABLE 613-6</b> . Only the No. 16, 30, 50 and 100 sieves may exceed the limits listed in <b>TABLE 613-1</b> provided the minimum retained percentage shown in <b>TABLE 613-6</b> is met.			

<b>TABLE 613-6: SPECIFICATION WORKING RANGES FROM THE JMF</b>										
<b>Mix Designation</b>	<b>Percent Retained – Square Mesh Sieves</b>									
	<b>¾"</b>	<b>½"</b>	<b>⅜"</b>	<b>No. 4</b>	<b>No. 8</b>	<b>No. 16</b>	<b>No. 30</b>	<b>No. 50</b>	<b>No. 100</b>	<b>No. 200</b>
Type A				±5	68 - 78	75 min	82 min.	87 min.	90 min.	94.0 – 96.0
Type B			±5	±4	73 - 83	77 min.	82 min	87 min.	90 min.	94.0 – 96.0
Type C		±5	±5	±4	73 - 83	77 min.	82 min	87 min.	90 min.	94.0 – 96.0

## 613 – ULTRATHIN BONDED ASPHALT SURFACE

**d. EBL Shot Rate Specification.** Periodically determine the application rate of the EBL. The Engineer will verify the application rate. Acceptable tolerance of the application rate is the target rate  $\pm 0.02$  gal/sq yd. Check for proper coverage at least twice per day by applying the EBL to the road surface for a minimum distance of 20 feet. When the Engineer verifies the coverage meets specification, back up the paver and shoot not more than 1/4 of the EBL shot rate over the previously tacked segment.

### 613.6 WEATHER LIMITATIONS

Do not place UBAS on any wet or frozen surface or when weather conditions otherwise prevent the proper handling and finishing of the mixture.

Only place UBAS when either the minimum ambient air temperature is 50°F or the minimum road surface temperature is 55°F.

### 613.7 MIXTURE ACCEPTANCE

**a. General.** Test the UBAS at each plant for compliance with **TABLE 613-1**. Acceptance will be made on a lot by lot basis contingent upon satisfactory test results. Obtain quality control and verification samples of the UBAS using KT-25 sampling procedure C.1 Plant Discharge or C.2 Truck Bed.

A load or loads of mixture which, in the opinion of the Engineer, are unacceptable for reasons such as being segregated, aggregate being improperly coated, foaming aggregate or being outside the mixing temperature range may be rejected.

**b. Lot Definition for Mix Production Sampling and Testing.** A lot is defined as an isolated quantity of a specified material produced from a single source or operation. Each lot shall normally be represented by 4 contiguous test results. A lot may be represented by test results on samples taken from 1 or more day's production.

**c. Lot Investigation.** The Engineer may examine materials represented by individual test results which lie beyond the Contractor's normal quality control testing variation. The investigation may be based on either Contractor or KDOT test results. The information from additional testing (including testing of in-place HMA) may be used to define unacceptable work according to **SECTION 105**. The Engineer may apply appropriate price reductions or initiate corrective action.

For any test, if a dispute exists between the Engineer and Contractor about the validity of the other's test results, the KDOT District Materials Laboratory or the MRC will perform referee testing. If the disputed KDOT test results were generated at the District Laboratory, the MRC will perform the referee tests. If the disputed KDOT test result was generated at the MRC, an independent laboratory agreeable to both parties will be selected. The Laboratory shall be accredited by the AASHTO Accreditation Program in the appropriate testing category.

If referee testing indicates that KDOT test results are correct, the Contractor pays for the additional testing, including referee testing performed at the MRC. This will be paid using the bid item Contract Deduct which will be an item added to the contract.

If the referee testing indicates that Contractor test results are correct, KDOT pays for the additional testing. Pay the independent lab for the testing and submit the paid invoice to KDOT. The Engineer will reimburse the Contractor (based on the invoice price) as Extra Work, **SECTION 104**.

**d. Multiple Projects.** If multiple projects are supplied from 1 or more plants using the same mix, carry over the lots at each hot mix plant from project to project.

**e. Lot Size.** A standard size mix production lot consists of 4 equal sublots of 400 tons each of asphalt mixture (lot size 1,600 tons). If the last sublot contains less than 200 tons, combine it with the previous sublot.

It is anticipated that lot size shall be as specified. However, with the Engineer's approval, the Contractor may re-define lot size for reasons such as, but not limited to, change in contract quantities or interruption of the work. Take 1 sample during production of each sublot and utilize it to determine disposition of the lot in which it occurs.

**f. Increased Lot Size.** After 8 consecutive sublots have been produced with the tolerances shown for all mix characteristics listed in **TABLES 613-5** and **613-6**, the sublot size may be increased by the Contractor to 500 tons each of asphalt mixture (lot size 2,000 tons), provided normal production rate of the plant is over 200 tons per hour. Immediately notify the Engineer of lot size change. If subsequent test results fall outside the tolerances

## 613 – ULTRATHIN BONDED ASPHALT SURFACE

shown for any mix characteristics listed in **TABLES 613-5** and **613-6**, the subplot size will be decreased to 400 tons. When the increased lot size criteria are again met, the subplot size maybe increased to 500 tons.

**g. Pre-Production Mix.** Test and evaluate a pre-production mix, limited to a maximum of 200 tons from each plant before production of that mix. Evaluate the pre-production mix at initial start-up and after suspension of production resulting from failing test results. Limit pre-production quantities to 100 tons following a suspension of production. Provide a pre-production mix that complies with the "Single Test Value" in **TABLES 613-5** and **613-6**. Except for initial start-up, normal delivery of material to the project before completion of certain test results on pre-production mixes may be authorized by the DME.

At the direction of the Engineer, remove the pre-production mix if it is both out of specification and the material shortens the pavement life or changes the intended function. The Engineer will pay for the replacement of one pre-production mix at 100% of the contract unit price. The payment will be full compensation to the Contractor for the placement and removal of that pre-production mix. KDOT will not be financially responsible for any subsequent failed pre-production mixes (that require removal) for that mix. The removed material is the property of the Contractor.

The Engineer will not pay for pre-production mixes that are required to be replaced due to poor workmanship or equipment failure. The Engineer will make the final decision to remove a failed pre-production mix with input from the Contractor.

**h. Suspension of Mix Production.** Suspend production of the mix until appropriate corrections have been made, if 2 consecutive test results for any single mix characteristic fail to fall within the limits established by the tolerances shown in the single test value column of **TABLE 613-5**. Additionally, suspend production of the mix until appropriate corrections have been made, if any 3-point moving average value for any single mix characteristic fails to fall within the limits established by the tolerances shown in the 3-point moving average value column of **TABLE 613-5**. Production remains suspended pending the satisfactory results of a pre-production mix, unless waived by the DME.

When the mix fails to meet the criteria listed in **TABLE 613-5**, identify the cause and document, in detail, what corrective action was taken. The JMF may only be adjusted, when requested by the Contractor, and when approved by the Engineer. For significant changes in the JMF, as determined by the Engineer, a new mix design may be required by the Engineer before the JMF is approved.

The Engineer may stop production of HMA at any time the mix or process is determined to be unsatisfactory. Make the necessary corrections before production will be allowed to resume. Failure to stop production of HMA subjects all subsequent material to rejection by the Engineer or acceptance at a reduced price, as determined by the Engineer.

### 613.8 MEASUREMENT AND PAYMENT

**a. Ultrathin Bonded Asphalt Surface.** The Engineer will measure UBAS by the ton of material at the time of delivery to the road. Batch weights will not be allowed as a method of measurement, unless all the following conditions are met:

- the plant is equipped with an automatic printer system approved by the Engineer;
- the automatic printer system prints the weights of material delivered; and
- the automatic printer system is used in conjunction with an automatic batching and mixing control system approved by the Engineer.

Provide a weigh ticket for each load. Due to possible variations in the specific gravity or weight per cubic foot of the aggregates, the tonnage used may vary from the proposal quantities and no adjustment in contract unit price will be made because of such variances.

Payment for "HMA Surface (Ultrathin Bonded)" at the contract unit prices is full compensation for the specified work including quality control testing.

Sideroads, entrances and mailbox turnouts that are not shown in the Contract Documents that are to be surfaced shall be paid for at 1½ times the unit price for "HMA Surface (Ultrathin Bonded)".

**b. Emulsified Asphalt.** The Engineer will measure emulsified asphalt used for tack by the ton. Payment for "Emulsified Asphalt (Emulsion Bonding Liquid)" at the contract unit price is full compensation for the specified work.



## 613 – ULTRATHIN BONDED ASPHALT SURFACE

**c. Quality Control Testing (HMA).** The Engineer will measure Quality Control Testing (HMA) performed by the Contractor on a per ton basis of UBAS placed on the project. No adjustment in the bid price will be made for overruns or underruns in the contract quantity. The bid price will constitute payment for all necessary mix design testing, field process control testing, the testing laboratory and all necessary test equipment.

Payment for "Quality Control Testing (HMA)" at the contract unit price is full compensation for the specified work.

**614 – HMA BASE (REFLECTIVE CRACK INTERLAYER (RCI))**

**SECTION 614**

**HMA BASE (REFLECTIVE CRACK INTERLAYER (RCI))**

**614.1 DESCRIPTION**

Construct the HMA-reflective crack interlayer (RCI) as designated in the Contract Documents.

**BID ITEMS**

HMA-RCI (PG 70-28 RCI)  
Quality Control Testing (HMA)

**UNITS**

Ton  
Ton

**614.2 CONTRACTOR QUALITY CONTROL REQUIREMENTS**

Perform quality control testing according to **subsection 602.2**. Develop control charts for the mix characteristics listed in **Table 614-7**.

**614.3 MATERIALS**

**a. Asphalt Binder.** Provide PG 70-28 RCI binder that complies with **SECTION 1202**, with this exception:

Post a legible copy of the latest bill of lading for the Asphalt Binder on or near the gyratory compactor. Use the mixing and compaction temperatures shown on the bill of lading; however, the maximum mixing or compaction temperature is 340°F, unless otherwise approved by the Field Materials Engineer. Notify the Engineer if the mixing or compaction temperature changes.

Exception: The mixing temperature may be increased no more than 10°F above the maximum mixing temperature shown on the bill of lading provided all the following are met:

1. The air temperature is below 70°F
2. The plant has not produced mix earlier in the day.
3. Do not exceed a mix temperature of 350°F.
4. No truck has returned for its second load of the day.

Once a previously loaded truck returns for its next load, reduce the temperature to not higher than the maximum mix temperature shown on the bill of lading, not to exceed 340°F.

**b. Reclaimed Asphalt Pavement (RAP) and Recycled Asphalt Shingles (RAS).** Do not use RAP or RAS in the RCI.

**c. Aggregates.** Provide aggregates that comply with **SECTION 1103**.

**d. Combined Aggregates.** Provide combined aggregates for the mixes required in the Contract Documents as shown in **TABLE 614-1**.

Mixes may use any combination of aggregate and mineral filler supplements complying with the applicable requirements in **TABLES 1103-1** and **1103-2**.

Provide materials with less than 0.5% moisture in the final mixture.

The maximum quantity of crushed steel slag used in the mix is 50% of the total aggregate weight.

Natural sand shall be called SSG-1, SSG-2, etc. in the mix design.

**e. Contractor Trial Mix Design.** A minimum of 10 working days before the start of HMA production, submit in writing to the DME for review and approval, a proposed JMF for each combination of aggregates. For each JMF submitted, include test data to demonstrate that mixtures complying with each proposed JMF shall have properties specified in **TABLE 614-1** for the designated mix type at the Recommended Percent Asphalt ( $P_{br}$ ). Submit the proposed JMF on forms provided by KDOT. Submit the worksheets used in the design process to include at a minimum the mix properties listed in **TABLE 614-2**. Contact the DME to determine if additional information should be submitted. Provide sufficient material as identified in **TABLE 614-3**. Submit for the Engineer's review and approval, the test data listed in **TABLE 614-4** for each blend and the proposed JMF. Provide a mix that meets the requirements in **TABLE 614-5**.

## 614 – HMA BASE (REFLECTIVE CRACK INTERLAYER (RCI))

For each aggregate used in the mix design, determine the specific gravity using KT-6. This may be accomplished while the project is being constructed or anytime during the 12 months preceding the start of construction on a project. If construction has not yet begun, notify the DME 5 working days prior to obtaining the material for the specific gravity test so that companion samples may be obtained at the same time. If construction has already begun on the project, then determine the specific gravity values of the individual aggregates before 10,000 tons of HMA is produced. Provide the test results to the DME within 14 days of sampling the material. If the producer of the aggregate has been required to submit material to KDOT for a new Official Quality test, since the time the Contractor ran the specific gravity tests, then perform KT-6 on the aggregate currently produced. Do not use the specific gravity values obtained from these tests in the mix design calculations for current projects, unless mutually agreeable to both parties. Use the information, as soon as it becomes available, as part of the process to verify and update the “Monthly Hot Mix Aggregate Specific Gravity Values” posted on KDOT’s Internet site.

For RCI mixes, the optimum percentage of asphalt material is the percentage that yields the design air voids at  $N_{des}$  (50 gyrations) and complies with the other requirements of the specifications. Submit test results for all design criteria. The values from the approved mix design become the values in the initial job mix formula (JMF) for the RCI. These values remain in effect for the JMF until a written request by the Contractor for a change is approved by the Engineer. Provide a new mix design when any change in materials occurs from those used in the mix design, unless waived by the DME.

<b>TABLE 614-1: COMBINED AGGREGATE REQUIREMENTS</b>								
<b>Mix Designation</b>	<b>Percent Retained - Square Mesh Sieves</b>							
	<b>¾"</b>	<b>No. 4</b>	<b>No. 8</b>	<b>No. 16</b>	<b>No. 30</b>	<b>No. 50</b>	<b>No. 100</b>	<b>No. 200</b>
RCI	0	0-15	1-25	13-47	41-68	74-91	88-99	94.0-99.0

1. Aggregate Adjustment Limit: Do not exceed a 7% adjustment on any single sieve from the approved mix design to the Job Mix Formula (JMF). Submit a new mix design when requesting a change beyond this limit.
2. Do not use RAP in the RCI design.
3. The flat and elongated particles in the combined coarse aggregate shall not exceed 10% for the total sample.
4. The maximum percent moisture in the final mixture shall not exceed 0.5.
5. There are no criteria for CAA, FAA, or D/B ratio.

<b>TABLE 614-2: MIX PROPERTIES</b>			
<b>Property</b>	<b>Abbreviation</b>	<b>Test Method</b>	<b>Additional Information</b>
Air Voids	$V_a$	KT-15 & KT-58	Calculated from $G_{mm}$ and $G_{mb}$ . Run at the $P_{br}$ .
Recommended Percent Asphalt	$P_{br}$		Produce a mix with a $V_a$ of 4.5%.
Theoretical Maximum Specific Gravity	$G_{mm}$	KT-39	Rice Test.
Sand Equivalent	SE	KT-55	
Bulk Specific Gravity of HMA	$G_{mb}$	KT-15	Compacted Mix Property.
Percent $G_{mm}$ at $N_{des}$	$\%G_{mm} @ N_{des}$ %	KT-15	Use $G_{mm}$ value from KT-39. Calculated from Gyratory Compaction height data, $G_{mm}$ , and $G_{mb}$ .
Voids in Mineral Aggregate	VMA	KT-15 & KT-6	Calculated from $G_{mb}$ , $G_{sb}$ , $P_b$ .
Voids Filled with Asphalt	VFA		Calculated from VMA and $V_a @ N_{des}$ .

Formulas for calculations are in the Superpave Volumetric Mixture Design and Analysis Handbook.

**614 – HMA BASE (REFLECTIVE CRACK INTERLAYER (RCI))**

<b>TABLE 614-3: MATERIAL SUBMITTALS</b>			
<b>Submittal</b>	<b>Quantity</b>	<b>Description</b>	<b>Additional Information</b>
Aggregate for KT-15	3 Samples	Sized for 6 inch Plugs	Comply with Job Mix Gradation.
Aggregate for KT-39	2 Samples	Sized for G <sub>mm</sub> Testing	Comply with Job Mix Gradation.
Binder for KT-15	As Needed	Sized for 3 Plugs at P <sub>br</sub>	
Binder for KT-39	As Needed	Sized for 2 G <sub>mm</sub> Tests	
Each Aggregate for KT-6	As Needed	Specific Gravity Test	
Uncompacted HMA Sample	35 lbs	Cool sample to room temperature	If transported hot and compacted within 2 hours, then requirement to cool sample may be waived by the DME.
Gyratory Plugs at N <sub>des</sub>	2 Plugs	Compacted at P <sub>br</sub>	Compacted to N <sub>des</sub>

<b>TABLE 614-4: TEST DATA SUBMITTALS</b>	
<b>Submittal</b>	<b>Information</b>
Asphalt Binder	Source, Grade, Specific Gravity, Mixing and Compaction Temperature from the Producer of the asphalt binder.
Each Aggregate	Source and Producer, including Legal Description.
Gradation of Each Aggregate	Percentage Retained to nearest 1% (except nearest 0.1% for No. 200 sieve)
Material Proportioning	Proportion of each material is shown in percentage of aggregate.
Composite Gradation	Based on Gradation of Each Aggregate and Material Proportioning.
Composite Gradation Plot	Plotted on KDOT Form 712 (0.45 power graph paper).
Asphalt Binder Added	Percentage to nearest 0.01% based on total weight of the mixture.
Aggregate	Percentage of flat and elongated particles in the coarse aggregate
Sand Equivalent	SE for the combined virgin aggregates.

<b>TABLE 614-5: RCI MIX REQUIREMENTS FOR DESIGN SUBMITTAL</b>	
<b>MIX CHARACTERISTIC</b>	<b>CRITERIA</b>
Sand Equivalent (SE), minimum, %	45
Gyratory Compaction Revolutions, N <sub>des</sub>	50
Air Voids (V <sub>a</sub> ) target, % <sup>(1)</sup>	4.5 <sup>(2)</sup>
VMA, minimum, % <sup>(1)</sup>	18.0
VFA, minimum, % <sup>(1)</sup>	70
Hveem Stability (AASHTO T-246) @ 140°F, 4" (100 mm) molds, minimum <sup>(1)</sup>	18.0
Flexural Beam Fatigue (AASHTO T-321) <sup>(3)</sup> , 2000 microstrain, 10 Hz., 98% ± 1.0 of Gmb @ N <sub>des</sub> , 59°F (Age samples for 4 hours at 275°F before compaction, reference AASHTO R30 Section 7.2)	200,000 cycles

- Criteria based on 50 gyrations (N<sub>des</sub>).
- Complete all tests on the mix producing 4.5% air voids at 50 gyrations. If the mix does not meet the requirements for all tests, then change the target air voids to correlate to the mix that does meet all the test requirements. Use this for all target air voids during production. The target asphalt binder content during production (JMF) will be the asphalt binder content from the approved mix design that yields the target air voids. Submit a new mix design to include the Hveem Stability and Flexural Beam Fatigue Testing when a new target asphalt binder content or target air voids is requested.
- AASHTO T-321 will be used for analysis with the following exceptions:
  - Section 8.7 Replace the last sentence with the following:  
This stiffness is the Initial Beam Modulus, which is used as a reference for determining the specimen failure.
  - Section 8.8: Delete the second sentence.
  - Section 8.9: Delete the last sentence.
  - Section 9.1.3: Change "Flexural Stiffness" to "Beam Modulus"
  - Section 9.1.6: Replace this section with the following:  
Normalized Modulus = (Beam Modulus x Cycle Number) / (Initial Beam Modulus x 50)  
Figure 6 - Plot the Normalized Modulus x Cycles versus Load Cycles (Repetitions)
  - Section 9.1.7 and Section 9.1.8: Delete
  - Section 9.1.9: Replace with the following:

## 614 – HMA BASE (REFLECTIVE CRACK INTERLAYER (RCI))

- Failure Point – Failure is defined at the maximum or peak Normalized Modulus when Normalized Modulus x Cycles is plotted versus Load Cycles.
- Section 9.1.10: Delete
- Section 10.4, Table 2: Change the last two headings to “Normalized Modulus” and “Normalized Modulus x Cycles”, respectively
- Section 10.7: Delete
- Section 10.8: Replace with the following:  
Prepare a plot of Normalized Modulus x Cycles versus load cycles

<b>TABLE 614-6: MIX DESIGN TEST DATA SUBMITTALS</b>	
<b>Submittal</b>	<b>Information</b>
Minimum of 1 Mix Design	As a minimum, 1 mix design at the $P_{br}$
$G_{mm}$	Determined at each binder content.
Individual and Bulk Specific Gravity Tests	Provide results for a minimum of 2 specimens at each binder content.
Percent Air Voids	Provide % $V_a$ in the mixture for each binder content when compacted to $N_{des}$ gyratory revolutions along with copies of the Gyratory graphs.
Percent VMA	Provide %VMA at each binder content.

### 614.4 CONSTRUCTION REQUIREMENTS

**a. Plant Operation.** Adjust all plant operations to operate continuously.

(1) Preparation of the Asphalt Binder. Heat the asphalt binder to within a range as specified in **SECTION 601**. When heating the asphalt binder to the specified temperature, avoid local overheating. At all times, provide a continuous supply of the asphalt binder to the mixer at a uniform temperature. Asphalt binder received from the refinery at temperatures less than 375°F may be used as received, if the requirements regarding the reheating of asphalt binder in **SECTION 601** are met.

(a) Commingling of Asphalt Binders. Do not add or commingle asphalt binders from 2 or more sources into a storage tank. If this occurs, the contents of the storage tank are considered contaminated. Do not use the contents of the storage tank on the project, except as follows: It is permissible, at the Contractor’s option, to thoroughly mix the contents of the tank and request sampling of the mixture. Submit the sample to the MRC for testing. Do not use the asphalt binder until approved, and when needed, a new mix design evaluation is completed.

(b) Asphalt Binder Sources. Before changing asphalt binder sources on a project, obtain approval from the DME. A new JMF may be required.

(2) Preparation of Mineral Aggregate. When the mineral aggregate is composed of 2 or more ingredients, combine as shown in the approved JMF.

(a) Temperature Requirements. Dry the aggregate for the mixture and heat to a temperature to obtain an asphalt-aggregate mixture temperature immediately after mixing within the 75 to 150 second Saybolt viscosity range of the asphalt binder used. Obtain the temperature for this viscosity range from the MRC or the Asphalt Binder Producer. No mixing or compaction temperatures are to exceed 340°F without approval from the Field Materials Engineer. The minimum temperature may be revised by the DME provided it is demonstrated that satisfactory results may be obtained at a lower temperature. In such event, deliver the HMA to the paver at a temperature sufficient to allow the material to be satisfactorily placed and compacted to the specified density and surface tolerance requirements.

(3) Preparation of HMA. Introduce asphalt binder into the prepared aggregate in the proportionate amount determined by the  $P_{br}$  in the JMF.

(a) Basis of Rejection. HMA will be rejected if the aggregate, as it is discharged from the drum or the pugmill, contains sufficient moisture to cause foaming of the mixture, or if the temperature of the aggregate is such that the asphalt-aggregate mixture temperature is outside the range specified in **SECTION 601**.

(b) Mixing Time. Operate drum mixers at a rate to provide uniform aggregate coating in a continuous operation. For batch and continuous type plants, the minimum wet mixing time is 40 seconds. In all cases, mix a sufficient time to produce a uniform mixture in which all the aggregate

## 614 – HMA BASE (REFLECTIVE CRACK INTERLAYER (RCI))

particles are thoroughly coated. On batch plants, begin the timing at the start of the asphalt binder introduction into the pugmill, and end upon the opening of the discharge gate. For continuous flow plants, mixing time in seconds shall equal:

[pugmill dead capacity in pounds] divided by [pugmill output in pounds per second].

(c) Manufacturer's Specifications. Operate all drying, pumping and mixing equipment within the limits specified by the manufacturer, unless it can be demonstrated to the satisfaction of the Engineer that such limits may be exceeded without detriment to the HMA.

(d) Batch Operation. Coordinate HMA batchers (Gob Hoppers) with the plant production rate at all times so the hopper is more than  $\frac{3}{4}$  full before the gates open, and the gates close before material can drop through the gob hopper directly into the surge bin, weigh hopper or truck.

(e) Wasted Material. Wasted material is not measured for pay.

If after an interruption of production, the drum-mixer contains cold, uncoated or otherwise unsuitable material, waste material through a diversion chute. In a continuous or batch plant drier, waste unsuitable material through the pugmill.

At the end of a production run, waste any segregated material in the cone of the storage bin.

(4) End of Day Quantities. At the end of each day of production, provide the Engineer with a document signed by the Plant Foreman or the Project Manager listing the dry weight of each aggregate, mineral filler and the tons of asphalt binder. The dry weight is the tons of the material less the water content.

**b. Road Surface Preparation.** Clean all foreign material and broom to remove dust from existing concrete pavement. Clean and fill cracks and joints, and construct surface leveling as shown in the Contract Documents.

Prior to placing the HMA, apply a tack coat to the existing surface, as shown in the Contract Documents. When warranted by weather conditions, the Engineer may authorize a change in the asphalt for tack coat. When such changes are made, the price per ton of material being used will be the unit price bid for the material designated in the contract plus or minus the difference in the invoice price per ton of the 2 materials at the refinery as determined at the time of application.

**c. Weighing Operations.** See SECTION 109 for details regarding weighing operations.

**d. Hauling Operations.** Schedule operations to minimize hauling over a surface course for the RCI.

Deliver HMA to the paver at a temperature sufficient to allow the material to be placed and compacted to the specified density and surface tolerance.

**e. Paving Operations.** The Engineer will check the pavement for longitudinal streaks and other irregularities. Make every effort to prevent or correct any irregularities in the pavement, such as changing pavers or using different and additional equipment.

Do not raise (dump) the wings of the paver receiving hopper at any time during the paving operation. The Engineer may waive this requirement if it is determined that raising (dumping) the wings will not produce detrimental segregation. If segregation or irregularities in the pavement surface or density are noted, review the plant, hauling and paving operations and take corrective action. The recommendations made in KDOT's "Segregation Check Points" should reduce the segregation and irregularities to an acceptable level. Copies of KDOT's "Segregation Check Points" may be obtained from the KDOT District Office or Field Engineer.

Spread the HMA and finish to the specified crown and grade using an automatically controlled HMA paver. Operate the paver at a speed to provide a uniform rate of placement without undue interruption. At all times, keep the paver hopper sufficiently full to prevent non-uniform flow of the HMA to the augers and screed.

If the automatic grade control devices break down, the Engineer may allow the paver to operate to the close of the working day, provided the surface is satisfactory.

(1) Surface Quality. Spread the HMA without tearing the surface. Strike a finish that is smooth, free of segregation, true to cross section, uniform in density and texture and free from surface irregularities. If the pavement does not comply with all of these requirements, plant production and paving will be suspended until the deficiency is corrected. The Engineer may verify segregation and uniformity of density requirements in TABLE 602-7 are met by using methods outlined in Section 5.8.3 – Segregation Check Using the Nuclear Density Gauge, Part V.

(2) Grade Control. Achieve grade control by use of 1 or more of the following grade reference devices. Approval of any of these devices will be based upon satisfactory performance.

(a) Traveling Stringline. Attach a traveling stringline or ski type attachment, a minimum length of 30 feet, to the paver and operate parallel with its line of travel.

## 614 – HMA BASE (REFLECTIVE CRACK INTERLAYER (RCI))

(b) Reference Shoe. Attach a short reference shoe or joint matching device to the paver for control in matching surface grades along longitudinal joints.

(c) Erect Stringline. Use an erected stringline consisting of a tightly stretched wire or string offset from and parallel to the pavement edge on 1 or both sides. Erect the stringline parallel to the established pavement surface grade and support at intervals as necessary to maintain the established grade and alignment.

(d) Stringless Paving. Control line, grade and pavement cross-section as shown in the Contract Documents. Use electronic guidance systems that meet the requirements and tolerances listed in **SECTION 802**. Horizontal control is guided by GPS. Vertical control is guided by Total Stations. GPS will not be allowed for Vertical control.

(3) Compaction of Mixtures. Uniformly compact the HMA as soon after spreading and strike-off as possible without shoving or tearing. Use self-propelled rollers operated at speeds slow enough to avoid displacement of the HMA. Equipment and rolling procedures which result in excessive crushing of the aggregate are prohibited. Use a sufficient number and weight of rollers to compact the HMA to the required density. Perform final rolling with a steel roller unless otherwise specified. On the final pass, operate finishing, vibratory rollers in the static mode.

Coordinate the frequency, amplitude and forward speed of the vibratory roller to achieve satisfactory compaction without objectionable undulations. For HMA lifts with a compacted thickness less than 1¼ inch, operate vibratory rollers in the static mode.

Keep rollers in operation as necessary so all parts of the pavement receive substantially equal compaction at the proper time. The Engineer will suspend HMA delivery to the project at any time proper compaction is not being performed.

Remove, replace with suitable material and finish according to these specifications any mixture that becomes loose, broken, mixed with foreign material or which does not comply in all respects with the specifications.

(4) Density Requirements. RCI mixes will not have a density pay adjustment. Control density using an approved rolling procedure with random nuclear gauge density determinations. Include a method for controlling density in the QCP.

Designate a "Compaction Foreman". This person shall control compaction procedures, review nuclear gauge results as they are obtained, adjust compaction procedures as needed to optimize compaction and report any changes in the compaction process and results of nuclear gauge testing to the Engineer. The compaction foreman may also be the nuclear gauge operator. The nuclear gauge operator shall continuously monitor compaction procedures. As a minimum, take 10 random nuclear gauge density determinations per day and report results to the Engineer. Throughout the day, nuclear gauge results shall be available for review by the Engineer. The compaction foreman shall document at a minimum of once every 2 hours that the approved rolling sequence is being followed. Documentation shall include roller passes, the mat temperature at each pass, amplitude setting of rollers and roller speed. Provide the documentation to the Engineer.

Determine and periodically update an approved rolling procedure as outlined in this section. As a minimum, evaluate the initial rolling procedure using 3 rollers. If the hot mix plant is operating at over 275 tons per hour, use a minimum of 4 rollers in the initial evaluation. The number of rollers may be reduced to 2 (or 3 if the plant is operating at over 275 tons per hour) provided cores (minimum of 3 sets of 3) are taken from both a segment (single truck load) using 3 rollers and a segment (single truck load) using 2 rollers (4 and 3 rollers, respectively if plant is running over 275 tons per hour). Determine the  $G_{mb}$  of the cores using KT-15. If the  $G_{mb}$  of the segment with less rollers is equal to or greater than the  $G_{mb}$  of the segment with more rollers, then the minimum number of rollers may be reduced by 1. Operate vibratory rollers in the static mode only. Evaluate RCI paver screed operation with the nuclear gauge at various vibration settings. For screed evaluation, take the nuclear gauge readings directly behind the screed and before rolling. The Compaction Foreman and Engineer will evaluate the densities obtained with the various roller combinations and screed settings to determine the initial approved rolling procedure.

Together, the Compaction Foreman and Engineer will determine when new rolling procedures are required. RCI production may be stopped by the Compaction Foreman or Engineer whenever rolling is not being performed according to the approved rolling procedure.

For all lots, achieve the maximum density before the temperature of the HMA falls below 175°F. Do not crush the aggregate. When the mat temperature falls below 175°F, roller marks may be removed from the mat with a self-propelled static steel roller.

(5) Contact Surfaces. Coat contact surfaces of curbing, gutters, manholes and similar structures with a thin uniform coating of asphalt material. Place the HMA uniformly high near the contact surfaces so that after compaction it shall be approximately ¼ inch above the edge of such structures.

## 614 – HMA BASE (REFLECTIVE CRACK INTERLAYER (RCI))

(6) Adjustment of Manholes (Set Price). When required, this work will be performed and paid for under **SECTION 816**.

(7) Construction Joints.

(a) Transverse Construction Joints. Use a method of making transverse construction joints to provide a thorough and continuous bond, provide an acceptable surface texture and meet density requirements. Do not vary the surface elevation more than 3/16 inch in 10 feet, when tested longitudinally across the joint. When required, repair the joints or paving operations will be suspended.

(b) Longitudinal Joints. Construct well bonded and sealed longitudinal joints to obtain maximum compaction at the joint. If deemed necessary by the Engineer to properly seal the joint, apply a light coat of asphalt emulsion or asphalt binder to the exposed edge before the joint is made.

Before placing the fresh HMA against a cut joint or against old pavement, spray or paint the contact surface with a thin uniform coat of asphalt emulsion or asphalt binder. Where a finishing machine is used, make the longitudinal joint by depositing a sufficient amount of HMA to form a smooth and tight joint.

Offset the longitudinal joint in successive courses by 6 to 12 inches. Comply with traffic lane edges for the width of the surface of top course placement.

**f. Maintenance of Traffic.** Maintain traffic according to **DIVISION 800** and the following:

Maintain one-way traffic, and restrict traffic speeds to 20 miles per hour in the vicinity of workers, unless otherwise designated. Use pilot cars to lead traffic through the area of paving and rolling operations, and if directed, through a curing area. The use of flaggers is allowed through patching operations, unless the patching area or distance between flaggers exceeds ½ mile, in which case the use of a pilot car shall be required. On overlay projects with 2 lanes or more in each direction for traffic use, the Engineer may waive the pilot car requirements.

Station one flagger ahead of the application of the tack coat and one flagger ahead of the area being protected from traffic. Take adequate protection for traffic on side roads approaching the tack area.

**g. Treatment of Adjacent Areas.** Pave sideroads, entrances and turnouts for mailboxes as shown in the Contract Documents. Overlay all widening areas designated in the Contract Documents or ordered by the Engineer.

**h. Special RCI Requirements.**

Technical Support: Personnel familiar with the process will provide technical support for production and placement of the RCI.

Tack Coat: Place a tack coat prior to the placement of the RCI.

Thickness: Compact the RCI, as a minimum, to the depth shown in the Contract Documents. Thicknesses less than the plan thickness are not acceptable and may result in removal and replacement at no additional cost to KDOT.

Longitudinal Joint: Overlap the PCCP or HMA longitudinal joint with the RCI by at least 6 inches.

Compaction and Density: Control the in-place density of all lots of the RCI using an approved rolling procedure as outlined in **subsection 614.4e**. If cores are taken use extreme care when handling the cores. Use a solid flat and un-textured surface to transport and store the cores prior to testing.

Release to Traffic and Overlay Placement: Cover the RCI with a hot mixture overlay within 10 days after placement. The RCI may be opened to traffic or covered with the hot mix overlay after cooling to less than 140°F or as determined by the Engineer.

Unacceptable work: Remove and replace areas determined unacceptable by the Engineer, in accordance with this specification, at no additional cost to KDOT.

Damaged Areas: Replace any traffic-damaged or marred areas at no additional cost to KDOT.

Blisters: Perforate blisters that are a minimum of 8" in diameter or a minimum of 1" high that have not disappeared by the time of the overlay using a method approved by the Engineer.

**i. Pavement Smoothness.** Evaluate pavement smoothness according to **SECTION 603**.

### 614.5 PROCESS CONTROL

**a. General.** Establish gradation limits and proportions for each individual aggregate and mineral filler. Specify the limits and proportions such that the material produced complies with the applicable requirements of the



## 614 – HMA BASE (REFLECTIVE CRACK INTERLAYER (RCI))

designated mix type. The Contractor is responsible for all process control operations including testing. At no time will KDOT's representative issue instructions to the Contractor or producer as to setting of dials, gauges, scales and meters. KDOT will collect and test verification samples and assurance samples and inspect the Contractor's quality control operations.

**b. JMF Adjustments.** Produce a mixture of uniform composition closely complying with approved design JMF to obtain the specified properties when compacted. If, during production, results from quality control tests demonstrate a need to make adjustments to the mix design, then make adjustments to the design JMF single point gradation and binder content to achieve the specified properties. The JMF adjustments shall produce a mix that complies with **TABLE 614-1** for the specified mix designation. When necessary, adjust on a subplot basis. Report the new JMF to KDOT's field representative and the DME before making such changes, and submit a new mix design for review and approval if required by the DME.

**c. Specification Working Ranges.** Establish acceptable limits for field test results by applying the tolerances shown in **TABLE 614-7** to the JMF or adjusted JMF for binder content and air voids. Establish acceptable limits for the other listed mix characteristics by applying the tolerances shown in **TABLE 614-7** to the requirements of **TABLE 614-1**.

<b>TABLE 614-7: SPECIFICATION WORKING RANGES (QC/QA)</b>				
<b>Mix Characteristics</b>	<b>Tolerance from JMF</b>			
	<b>Single Test Value</b>	<b>Plot</b>	<b>4 Point Moving Average Value</b>	<b>Plot</b>
Binder Content	±0.5%	*	±0.3%	*
Air Voids @ N <sub>des</sub> gyrations	±1.0%	*	±1.0%	*
<b>Mix Characteristics</b>	<b>Tolerance for Specification Limits</b>			
	<b>Single Test Value</b>	<b>Plot</b>	<b>4 Point Moving Average Value</b>	<b>Plot</b>
Gradation (applicable sieves shown in <b>TABLE 614-1</b> )	**	*	zero tolerance	*
Voids in Mineral Aggregate	1.0% below min.	*	zero tolerance	*
Voids Filled with Asphalt	zero tolerance		n/a	
Sand Equivalent	zero tolerance		n/a	

\*Values to plot. For gradations, as a minimum, plot the No. 8, No. 16, No. 50, and No. 200 sieves.

\*\* The maximum deviation from the JMF shall be ±4% for No. 16 sieve and ±1.0% for No. 200 sieve.

### 614.6 WEATHER LIMITATIONS

Do not place HMA on any wet or frozen surface or when weather conditions otherwise prevent the proper handling and finishing of the mixture.

Only place HMA when either the minimum ambient air temperature or the road surface temperature shown in **TABLE 614-8** is met.

<b>TABLE 614-8: MINIMUM RCI PLACEMENT TEMPERATURES</b>			
<b>Paving Course</b>	<b>Thickness (inches)</b>	<b>Air Temperature (°F)</b>	<b>Road Surface Temperature (°F)</b>
RCI	All	50	55

### 614.7 MIXTURE ACCEPTANCE

**a. General.** Test the RCI at each plant for compliance with **TABLE 614-1**. Acceptance will be made on a lot by lot basis contingent upon satisfactory test results. Obtain quality control and verification samples of the RCI using KT-25 sampling procedure D.2 Truck Bed. The sampling device and procedures used to obtain and split the samples must be approved by the Engineer. The Contractor's quality control tests will be used for acceptance provided those results are verified by KDOT.

## 614 – HMA BASE (REFLECTIVE CRACK INTERLAYER (RCI))

A load or loads of mixture which, in the opinion of the Engineer, are unacceptable for reasons such as being segregated, aggregate being improperly coated, foaming aggregate or being outside the mixing temperature range may be rejected. The Engineer will take verification samples using the same sampling and splitting procedure as approved for the Contractor's quality control tests.

The  $P_b$  test values will also be used to determine  $P_b$  pay adjustments according to **subsection 614.8b**.  $P_b$  pay adjustments apply to the RCI placed on the traveled way and shoulders (including ramps and acceleration and deceleration lanes).

**b. Lot Definition for Mix Production Sampling and Testing.** A lot is defined as an isolated quantity of a specified material produced from a single source or operation. Each lot shall normally be represented by 4 contiguous test results. A lot may be represented by test results on samples taken from 1 or more day's production.

**c. Lot Investigation.** The Engineer may examine materials represented by individual test results which lie beyond the Contractor's normal quality control testing variation. The investigation may be based on either Contractor or KDOT test results. The information from additional testing (including testing of in-place RCI) may be used to define unacceptable work according to **subsection 105.5**. The Engineer may apply appropriate price reductions or initiate corrective action.

For any test, if a dispute exists between the Engineer and Contractor about the validity of the other's test results, the KDOT District Materials Laboratory or the MRC will perform referee testing, except for  $P_b$  dispute resolution. If the disputed KDOT test results were generated at the District Laboratory, the MRC will perform the referee tests. If the disputed KDOT test result was generated at the MRC, an independent laboratory agreeable to both parties will be selected. The Laboratory shall be accredited by the AASHTO Accreditation Program in the appropriate testing category.

If referee testing indicates that KDOT test results are correct, the Contractor pays for the additional testing, including referee testing performed at the MRC. This will be paid using the bid item Contract Deduct which will be an item added to the contract.

If the referee testing indicates that Contractor test results are correct, KDOT pays for the additional testing. Pay the independent lab for the testing and submit the paid invoice to KDOT. The Engineer will reimburse the Contractor (based on the invoice price) as Extra Work, **SECTION 104**.

For  $P_b$  dispute resolution (the statistical comparison fails and the Contractor questions KDOT results), the following procedure applies for the lots in question:

- Determine which lots to dispute. Only dispute the lot produced immediately prior to the lot currently under production and being tested. Notify the Engineer, prior to the completion of all Contractor  $P_b$  testing for this lot. (When production is completed for any mix, the last lot may be challenged the day production is completed).
- Discard  $P_b$  and  $P_b$  pay adjustment factors previously determined within the lots being questioned.
- All back halves of samples within the lot in question will be taken by KDOT to the District Materials Laboratory. All back halves of samples shall be a minimum of 35 pounds. Failing to obtain enough material removes the right to dispute resolution. Copies of all paperwork, including work sheets, associated with previous  $P_b$  calculations for the disputed lots will also be taken to the District Materials Laboratory.

The following retesting will be completed by KDOT:

- Determine the  $P_b$  using the back half of all samples within the lot being questioned using KT-57. Normally, there will be 5 back halves (4 Contractor's and 1 KDOT) to test within each lot.
- Using the retest  $P_b$  results, a statistical comparison will be made. If the t-test passes, the Contractor's retest results will be used to calculate the pay factor and KDOT will pay for all retesting. Use the procedures shown in **subsection 614.8b**. If the t-test fails, KDOT's retest results will be used to calculate the pay factor, and the Contractor will pay for all retesting.

When a deficiency within a lot is determined to exist for properties other than  $P_b$  ( $P_b$  deficiencies are addressed elsewhere in the specification), the Engineer will decide on the disposition of each lot as to the acceptance, rejection or acceptance at an adjusted payment. The Engineer's decision is final.

**d. Resampling of Lots.** Take no samples for retest for pay adjustment purposes except as noted in **subsection 614.7c**.

## 614 – HMA BASE (REFLECTIVE CRACK INTERLAYER (RCI))

**e. Multiple Projects.** If multiple projects are supplied from 1 or more plants using the same mix, carry over the lots at each hot mix plant from project to project.

**f. Lot Size.** A standard size mix production lot consists of 4 equal sublots of 750 tons of RCI (lot size is 3,000 tons).

It is anticipated that lot size shall be as specified. However, with the Engineer's approval, the Contractor may re-define lot size for reasons such as, but not limited to, change in contract quantities or interruption of the work. Take 1 sample during production of each subplot and utilize it to determine disposition of the lot in which it occurs.

**g. Increased Lot Size.** After 8 consecutive sublots have been produced within the tolerances shown for all mix characteristics listed in **TABLE 614-7** and without a  $P_b$  penalty, the subplot size may be increased to 1,000 tons (lot size of 4,000 tons), provided the normal production rate of the plant is greater than 250 tons per hour. Provide immediate notification of lot size changes to the Engineer any time a change is made.

If subsequent test results fall outside the tolerances shown for any mix characteristic listed in **TABLE 614-7** or a  $P_b$  penalty is incurred, the subplot size shall be decreased to 750 tons. When the increased lot size criteria are again met, the subplot size may be increased to the limits given above.

**h. Decreased Lot Size for Small Quantities.** This is to be used when a small quantity (less than 3,000 tons) of RCI will be used. Use the plan quantity for the lot size. Reduce the subplot size below 750 tons by dividing the lot into 3 or 4 equal sublots. Before beginning production, provide the Engineer with the number and size of the sublots.

**i. Pre-Production Mix.** Test and evaluate a pre-production mix, limited to a maximum of 200 tons from each plant and type of mix before production of that mix. Evaluate the pre-production mix at initial start-up and after suspension of production resulting from failing test results.  $P_b$  payment shall not be adjusted for pre-production mixes. Provide a pre-production mix that complies with the gradation,  $P_b$ , VMA, and laboratory  $V_a$  requirements prior to starting or resuming production. For  $P_b$ ,  $V_a$ , and VMA, use the "Single Test Value" listed in **TABLE 614-7** for comparison. For the other tests listed, use the values listed in **TABLE 614-1** for each mix. Except for initial start-up, normal delivery of material to the project before completion of certain test results on pre-production mixes may be authorized by the DME.

Place the material produced for the pre-production mix in locations approved by the DME. The Engineer will pay for material as the material produced. At the direction of the Engineer, remove the pre-production mix if it is both out of specification and the material shortens the pavement life or changes the intended function. The Engineer will pay for the replacement of one pre-production mix at 100% of the contract unit price for the RCI. The payment will be full compensation to the Contractor for the placement and removal of that pre-production mix. KDOT will not be financially responsible for any subsequent failed pre-production mixes (that require removal) for the RCI. The removed material is the property of the Contractor.

The Engineer will not pay for pre-production mixes that are required to be replaced due to poor workmanship or equipment failure. The Engineer will make the final decision to remove a failed pre-production mix with input from the Contractor.

**j. Suspension of Mix Production.** Suspend production of the mix until appropriate corrections have been made, if 2 consecutive test results for any single mix characteristic fail to fall within the limits established by the tolerances shown in the single test value column of **TABLE 614-7**. Additionally, suspend production of the mix until appropriate corrections have been made, if any 4-point moving average value for any single mix characteristic fails to fall within the limits established by the tolerances shown in the 4-point moving average value column of **TABLE 614-7**. Production remains suspended pending the satisfactory results of a pre-production mix, unless waived by the DME.

The Engineer may stop production of RCI at any time the mix or process is determined to be unsatisfactory. Make the necessary corrections before production will be allowed to resume. Failure to stop production of RCI shall subject all subsequent material to rejection by the Engineer or acceptance at a reduced price, as determined by the Engineer.

**614.8 BASIS OF ACCEPTANCE**

**a. General.** Acceptance of the mixture will be contingent upon test results from both the Contractor and KDOT. The Engineer will routinely compare the variances (F-test) and the means (t-test) of the verification test results with the quality control test results for  $P_b$  using a spreadsheet provided by KDOT. If KDOT verification test results do not show favorable comparison with the Contractor’s quality control test results, then KDOT test results will be used for material acceptance, material rejection and the determination of any pay adjustment on the  $P_b$ . Disputed test results will be handled according to **subsection 614.7c**.

KDOT will use a spreadsheet program to calculate pay adjustments for  $P_b$ , and to compare Contractor QC and KDOT QA test results. KDOT will provide a copy of this program to the Contractor, when requested. Microsoft Excel software is required to run this program; it is the Contractor’s responsibility to obtain the correct software. Values computed using equations referenced in this specification may vary slightly from the spreadsheet values due to rounding of numbers. In such cases, the numbers computed by the spreadsheet will govern.

The comparison of quality control and verification tests will be completed using the t-tests to compare their population means and the F-test to compare their variances. The F & t tests, along with the Excel Spreadsheet used to compare the Contractor’s QC results and KDOT’s QA results, are described in Section 5.2.6, Part V. Additional information on the program may be obtained from the Bureau of Construction and Materials.

**b. Asphalt Binder Pay Adjustment.** Asphalt Binder ( $P_b$ ) Pay Adjustment will be made on a lot basis and based on measured  $P_b$  from samples of plant produced material. The  $P_b$  pay adjustment factor ( $P_B$ ) (positive or negative) will be determined and used to compute the  $P_b$  pay adjustment by multiplying  $P_B$  times the number of tons included in the lot times \$40 per ton. This adjustment will be paid for under the bid item Asphalt Binder Pay Adjustment. When the statistical comparison between the quality control and the verification tests pass, use the procedures in **subsection 614.8b.(1)** to compute  $P_B$ . When the statistical comparison fails, calculate  $P_B$  using procedures in **subsection 614.8b.(2)**.

**Asphalt Binder Lot Size:** A lot shall normally be comprised of the results of 4 contiguous individual  $P_b$  tests as determined from the ignition oven burn-off procedure (KT-57).

(1) Asphalt Binder Pay Adjustment Factor (Passing t-test). Calculate the upper and lower  $P_b$  quality indices ( $Q_{UB}$  and  $Q_{LB}$ ) for each lot using Equations 3 and 4, respectively and round to hundredths. Locate the  $Q_{UB}$  value in the left column of the Percent Within Limits (PWL) Table in Section 5.2.1, Part V. Select the appropriate upper percent within limit value ( $PWL_{UB}$ ) by moving across the selected quality index row to the column representing the number of samples (N) in the lot. Repeat the process using the  $Q_{LB}$  value and select the appropriate value for the lower percent within limits ( $PWL_{LB}$ ). If the  $Q_{UB}$  or  $Q_{LB}$  value is greater than the largest quality index value shown in the table, then a value of 100.00 is assigned as the value for  $PWL_{UB}$  or  $PWL_{LB}$ , respectively. If both  $Q_{UB}$  and  $Q_{LB}$  exceed the values shown in the table, a value of 100.00 is assigned as the value for both  $PWL_{UB}$  and  $PWL_{LB}$ . If either  $Q_{UB}$  or  $Q_{LB}$  is a negative value or  $PWL_{UB} + PWL_{LB}$  is less than 150.00, the Engineer will determine if the material in the lot may remain in place. If the Engineer determines that the material may remain in place then the maximum value of  $P_B$  for the lot will be equal to -0.060. The Engineer may establish lower values for  $P_B$  (-0.100, -0.200, etc.) in such instances. Otherwise, calculate  $P_B$  using Equation 3 and round to thousandths.

**Equation 1:** 
$$Q_{UB} = \frac{USL - \bar{X}}{S}$$

**Equation 2:** 
$$Q_{LB} = \frac{\bar{X} - LSL}{S}$$

$\bar{X}$  is the average measured  $P_b$  of all samples within a lot rounded to hundredths.

USL is the upper specification limit for  $P_b$ , and is defined as 0.30% higher than the JMF  $P_b$ .

LSL is the lower specification limit for  $P_b$ , and is defined as 0.30% lower than the JMF  $P_b$ .

S is the standard deviation of the measured  $P_b$  for all samples within a lot and is calculated using equation (4) in Section 5.2.1, Part V, rounded to hundredths.

**Equation 3:** 
$$P_B = ((PWL_{UB} + PWL_{LB} - 100)(0.0015)) - 0.135$$

$PWL_{UB}$  is the upper percent within limits value for  $P_b$ .

$PWL_{LB}$  is the lower percent within limits value for  $P_b$ .

**614 – HMA BASE (REFLECTIVE CRACK INTERLAYER (RCI))**

(2) Asphalt Binder Pay Adjustment (Failing t-Test). If the t-test fails, KDOT’s test result will be used to calculate the  $P_B$  for the lot. Follow the procedures given in **subsection 614.8b.(1)** to determine the  $P_B$  or disposition of the lot. Use the values from **TABLE 614-9** to calculate  $Q_{UB}$ ,  $Q_{LB}$ ,  $PWL_{UB}$  and  $PWL_{LB}$  in Equations 1, 2 and 3 in **subsection 614.8b.(1)**.

<b>TABLE 614-9: Statistical Values for Asphalt Binder Pay Adjustment for Failing t-Test</b>		
<b>Term</b>	<b>Definition</b>	<b>Value</b>
$\bar{X}$	Average or Mean	KDOT’s test result for the lot
S	Standard Deviation	0.20
USL	Upper Specification Limit	0.50% + JMF $P_b$
LSL	Lower Specification Limit	JMF $P_b$ - 0.50%
N	Sample Size	3

**614.9 MEASUREMENT AND PAYMENT**

**a. HMA-RCI (PG 70-28 RCI).** The Engineer will measure HMA -RCI by the ton of material at the time of delivery to the road. Batch weights will not be allowed as a method of measurement unless all the following conditions are met:

- the plant is equipped with an automatic printer system approved by the Engineer;
- the automatic printer system prints the weights of material delivered; and
- the automatic printer system is used in conjunction with an automatic batching and mixing control system approved by the Engineer.

Provide a weigh ticket for each load. Due to possible variations in the specific gravity or weight per cubic foot of the aggregates, the tonnage used may vary from the proposal quantities and no adjustment in contract unit price will be made because of such variances.

Payment for "HMA -RCI" at the contract unit prices is full compensation for the specified work. Any pay adjustments will both be applied and the payment adjusted accordingly.

**b. Emulsified Asphalt.** The Engineer will measure emulsified asphalt used for tack by the ton. Payment for "Emulsified Asphalt" at the contract unit price is full compensation for the specified work.

**c. Quality Control Testing (HMA).** The Engineer will measure Quality Control Testing (HMA) performed by the Contractor on a per ton basis of HMA-RCI placed on the project. No adjustment in the bid price will be made for overruns or underruns in the contract quantity. The bid price will constitute payment for all necessary mix design testing, field process control testing, the testing laboratory and all necessary test equipment.

Payment for "Quality Control Testing (HMA)" at the contract unit price is full compensation for the specified work.

## 615 – SAW AND SEAL JOINTS (HMA OVERLAY)

### SECTION 615

#### SAW AND SEAL JOINTS (HMA OVERLAY)

##### 615.1 DESCRIPTION

Provide materials for, locate, saw, clean, and seal joints in the HMA overlay at the locations shown in the Contract Documents or as designated by the Engineer.

##### BID ITEMS

Saw and Seal Joint (HMA)  
Asphalt Core (Set Price)

##### UNITS

Linear Foot  
Each

##### 615.2 MATERIALS

Provide hot type joint sealing compound complying with **DIVISION 1500**.

##### 615.3 CONSTRUCTION REQUIREMENTS

**a. General.** Begin the saw and seal operation a minimum of 48 hours after placing the surface course to allow the mat to cool. Complete the saw and seal operation prior to the end of the construction season (as established for asphalt paving) or project completion, whichever is earlier.

Coordinate the sawing, cleaning and sealing in a continuous operation.

**b. Sawing the Joint.** Reference the location of the existing joints in the concrete pavement before placing the HMA overlay by methods approved by the Engineer.

Use a saw that will produce a smooth cut for the required depth and width.

Configure the joints according to **FIGURE 1** within 1 inch horizontally above the existing joint.

Saw the entire depth and width in one single pass for the entire length of the cut.

Saw transverse joints the entire width of the HMA Overlay.

Use either a dry or wet saw method.

**c. Clean the entire depth of the cracks.** If the wet saw method is used, flush wet sawed joints with high pressure water until the water runs clear.

For either saw method, remove all material created by sawing operation and other foreign material that will prevent bonding of the sealant. Remove loose material on the surface immediately adjacent to the joints and cracks. Clean and dry the crack using air compressors equipped with suitable traps capable of removing all surplus water and oil from the compressed air.

**d. Joint Depth and Location Verification.** Before sealing the joints, the Engineer will randomly identify two transverse joints per lane-mile. Cut a 4-inch core through the entire depth of the HMA and PCCP at these locations.

The Engineer will measure the depth of the HMA overlay, the depth of the saw cut and the horizontal offset between the underlying PCCP joint and the sawed joint.

If the sawed joint is offset by more than the 1 inch tolerance, the Contractor will be assessed a Contract Deduct of 40% of the bid price for the lineal feet of joints represented by the deficient core.

(1) HMA Overlay > 1.0 inch. If the depth of the saw cut is less than the half of the HMA thickness,  $\pm 1/8$  inch, re-saw every joint to the required depth in the segment represented by the core. Take additional cores for verification of re-sawed joints, at randomly selected locations determined by the Engineer.

Dry the core holes, tack the sides and bottom, fill with the same type of material and properly compact.

615 – SAW AND SEAL JOINTS (HMA OVERLAY)

FIGURE 615-1: FULL-WIDTH SAW CUT, HMA OVERLAY > 1.0 INCH

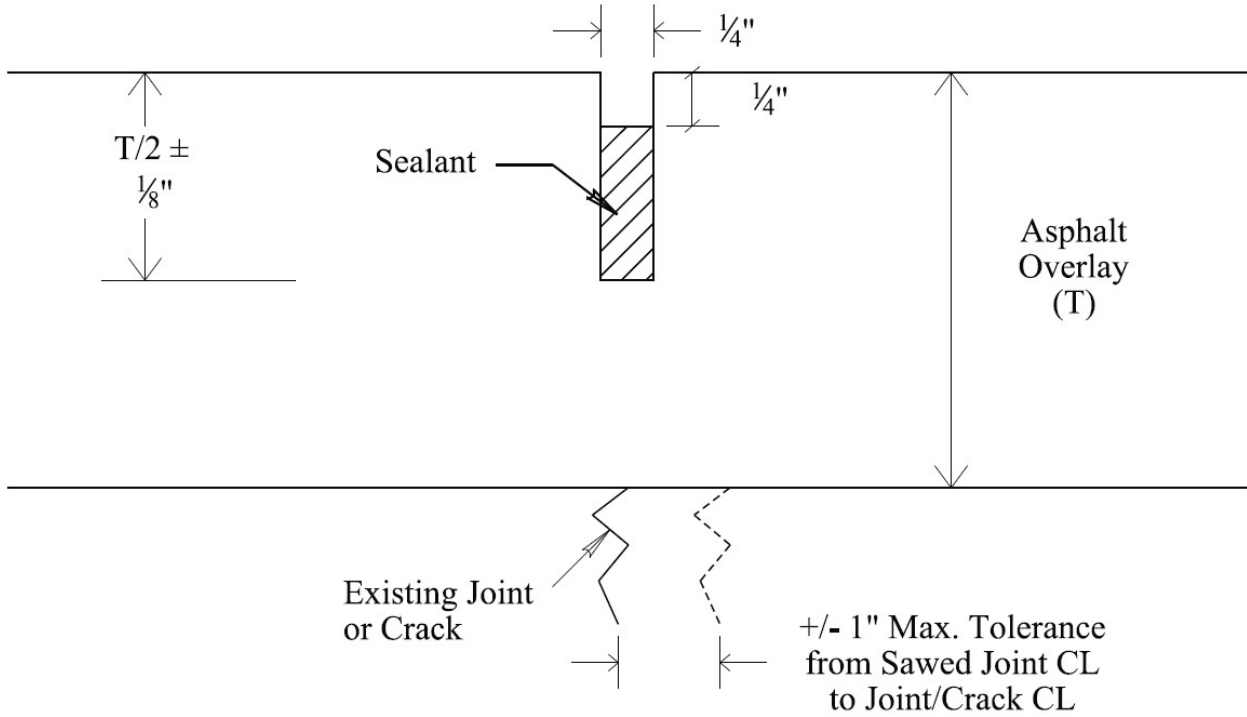

(2) HMA Overlay  $\leq 1.0$  inch. If the depth of the saw cut is less than the full HMA overlay thickness, re-saw every joint to the required depth in the segment represented by the core. Take additional cores for verification of re-sawn joints, at randomly selected locations determined by the Engineer.

Dry the core holes, tack the sides and bottom, fill with the same type of material and properly compact.

FIGURE 615-2: ENTIRE-DEPTH, FULL-WIDTH SAW CUT, HMA OVERLAY  $\leq 1.0$  INCH

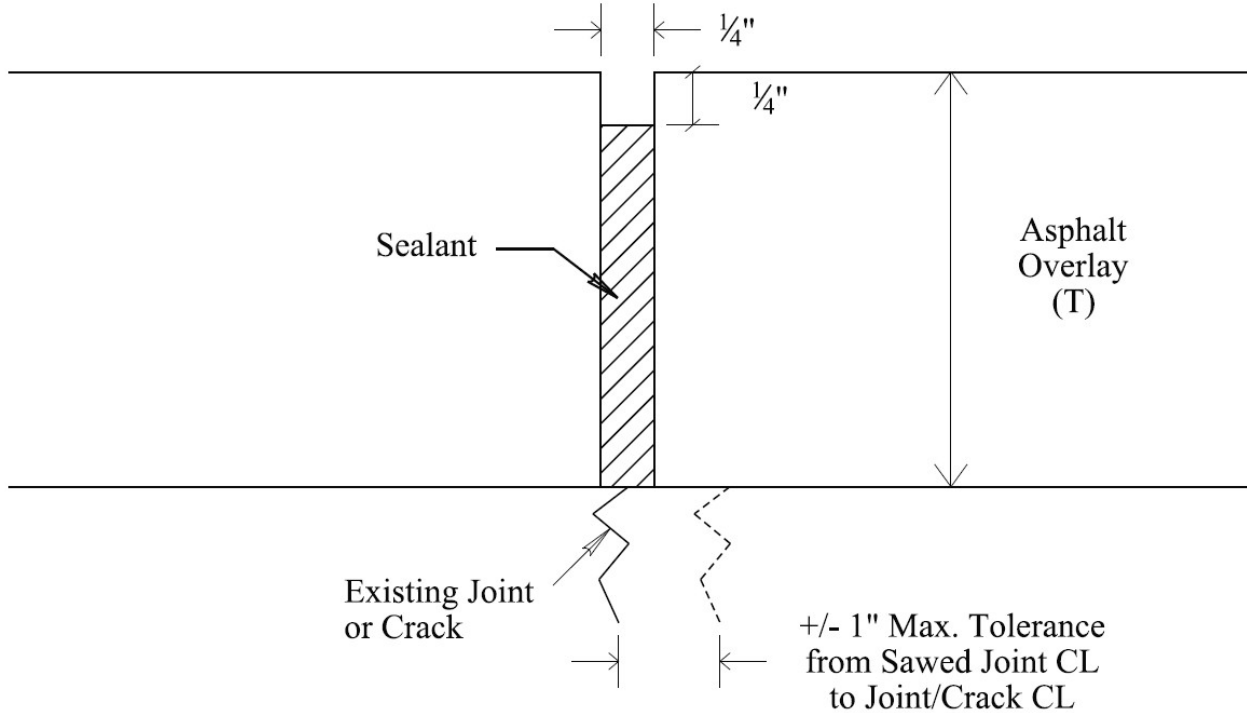

## 615 – SAW AND SEAL JOINTS (HMA OVERLAY)

**e. Preparation of Asphalt for Joint Sealing.** Provide 2 copies of the manufacturer's recommendations for preparation and application of the sealant. Prepare and use the material according to the manufacturer's recommendations.

**f. Sealing the Joint.** Apply the joint sealant by an approved mechanical device. Place the sealer the entire depth in close conformity with dimensions shown in the Contract Documents. Fill joints to a level 1/4-inch recessed from the pavement surface.

Do not permit traffic over sealed joints until the sealer is tack free, or until debris from traffic can not imbed into the sealant and sealant does not track under tires.

**g. Weather Limitations.** Do not place sealant when the ambient air temperature is below 40°F.

### 615.4 MEASUREMENT AND PAYMENT

The Engineer will measure sawing and sealing joints by the linear foot along the center of the joint. The Engineer will measure each asphalt core required to verify the saw depth and location.

Payment for "Saw and Seal Joint (HMA)" and "Asphalt Core (Set Price)" at the contract unit price will be full compensation for the specified work.

The Engineer will apply a Contract Deduct of 40% of the bid price for lineal feet of deficient joint offsets as determined in **subsection 615.3d.** above. The bid item Contract Deduct will be an item added to the contract.



