

SECTION 714**PAINTING STRUCTURAL STEEL****714.1 DESCRIPTION**

Prepare the structural steel surfaces, and paint the structural steel as shown in the Contract Documents. Provide environmental protection as necessary.

BID ITEMS

Bridge Painting (*)
Environmental Protection
Power Wash
*Type of Paint System

UNITS

Lump Sum
Lump Sum
Lump Sum

714.2 MATERIALS

Provide paint materials that comply with **DIVISION 1800**.

Formulate the inorganic zinc or organic zinc coating to provide a tint which distinctly contrasts with blast cleaned metal surfaces and the finish coat.

714.3 CONSTRUCTION REQUIREMENTS**a. General Requirements for Painting Structural Steel.**

(1) Surface Preparation Before Applying The Prime Coat. Blast all surfaces with abrasives to produce a height of profile of 1 to 3 mils.

Clean structural steel surfaces to meet the Society for Protective Coatings' (SSPC) specification SSPC-SP10, Near-White Blast Cleaning. Limit staining to a maximum of 5% of each square inch of surface area.

If specified (such as for unpainted surfaces of weathering steel or when repainting existing bridges in kind), clean structural steel surfaces to meet SSPC-SP6, Commercial Blast Cleaning, except wet blasting will not be permitted. Staining is limited to a maximum of 33% of each square inch of surface area. If the original surface is pitted, slight residues of rust and paint may be left in the bottom of pits.

Staining may consist of slight shadows, slight streaks or minor discoloration caused by stains of rust, stains of mill scale or stains of previously applied paint. When viewed without magnification, the blast cleaned surface shall be free of visible oil, grease, dust, dirt, mill scale, rust, coating, oxides, corrosion products and other foreign matter.

Remove all machine cutting oil by cleaning machined surfaces (ANSI 125 micro-inch or smoother). Carefully mask the machined surfaces before blast cleaning the remaining surfaces of the member.

After blast cleaning, remove any trace of blast products. Take care to remove abrasives from pockets and corners.

Give the blast cleaned surfaces a prime coat of paint within 12 hours of cleaning. Re-clean the blast cleaned surfaces if rust tinge appears before the prime coat is applied.

(2) Weather Conditions. Check the air temperature, the steel temperature and the dew point before painting begins each day, and after each suspension of painting due to weather or temperature, if painting is to resume. Do not apply paint if the ambient air temperature is below 40°F, when the air is misty, when the steel temperature is 5° or less above the dew point, or if the Engineer determines conditions are unsatisfactory for painting. Do not apply paint on damp or frosted surfaces. Stop paint application if the Engineer determines the air temperature is so high that the spray dries before reaching the surface, resulting in a dry, powdery coating.

(3) Mixing and Thinning Paint. Thoroughly mix the paint and keep the pigment in suspension. Strain the mixed paint when recommended by the manufacturer.

If multi-component inorganic zinc primer is used, follow the manufacturer's instructions regarding the amount and manner of adding the zinc dust to the liquid portion. Strain the mixed paint through a metal screen having a mesh recommended by the manufacturer. Mix multi-component inorganic zinc paint fresh each day and do not use it past the pot life time stated in the manufacturer's literature.

The Engineer will permit paint thinning if required for proper application, but only as recommended by the manufacturer. If thinner is used, add it to the paint during the mixing process. Do not add additional thinner after the paint is thinned to the proper consistency.

Use thinner recommended by the manufacturer for inorganic zinc paints. Inorganic zinc paint should not require heating in cool weather, but is permitted provided care is taken that the paint is protected from all moisture.

(4) Application of Paint. Apply the paint according to the manufacturer's instructions. Provide the Field Engineer with a printed copy of the paint manufacturer's application instructions.

Apply the paint using either a conventional or an airless sprayer. Spray from a continuously agitated pot.

Apply uniform coatings in tight contact with the metal. Work the coating into all corners and crevices. Apply a coating that is free of all defects.

Allow ample time for each paint coating to dry. Do not apply the next coat of paint until the previous coat is inspected by the Engineer and found dry and hard throughout the entire film thickness.

Remove and replace defective or unauthorized paint. Prepare the surfaces for repainting and repaint the areas according to the requirements for painting structural steel.

When the finish coat is complete, stencil (in black paint) the date the bridge was painted and the code representing the type of paint system used on the bridge. Stencil the legend on the right side of the outside face of the far right stringer near each end of the bridge. Use capital letters, 2 to 3 inches in height. The date stencil shall contain the word "PAINTED" and show the month and the year that the painting was completed. Make the paint system code selection from the following list:

Inorganic Zinc/Acrylic	IZ/A
Inorganic Zinc/Polyurethane	IZ/P
Organic Zinc/Acrylic	OZ/A
Organic Zinc/Polyurethane	OZ/P

(5) Staging and Scaffolding. Use adequate staging and scaffolding while painting the structural steel. Do not climb or work on the finished painted members. Provide the Engineer with safe means (such as scaffolding, snoopers or cherry pickers) to inspect any portion of the structure during the cleaning and painting operations.

(6) Protection of Pedestrians and Property. When painting on the project site, protect all pedestrians, vehicles (on or underneath the bridge), adjoining property along the right-of-way, pipes or ducts owned by utility companies, and portions of the bridge superstructure and substructure against damage or disfigurement from paint material. The Contractor is responsible for repairing any damage resulting from the painting operations.

(7) Maintaining Traffic on Existing Bridges. Provide traffic control as shown in Contract Documents and **SECTION 805**. Unless traffic is detoured, maintain traffic on the existing bridge at all times during the work of cleaning and painting. At the option of the Contractor when work is being performed, ½ of the roadway on that span may be closed to traffic, with one way traffic being maintained over the other half of the roadway. At all other times when work is not being performed, keep the entire bridge roadway open to traffic.

b. Shop Painting Structural Steel (Non-Weathering). The application of the prime coat in the shop must comply with the general requirements for painting structural steel, with these additions and exceptions:

Unless shown otherwise in the Contract Documents, apply 1 coat of inorganic zinc primer to the structural steel in the shop. Mask machined surfaces prior to painting. Use primer that is tinted to contrast (in color) with the blast-cleaned steel and with the finish coat of paint.

Apply 2 primer coats (not less than 6 mils total thickness) to surfaces that are not in contact with the concrete, but that will be inaccessible after assembly or erection. Apply the second coat between 4 and 24 hours after application of the first coat. Prime the welded stud shear connectors (including the underside of the stud head). Given the complexity, areas of thin primer and some shadows are permissible on the top 1 inch.

Except where otherwise indicated, coat all blast cleaned surfaces of the structural steel, including contact surfaces of high strength bolted connections and areas in contact with concrete. The dry film thickness of the prime coat shall be 3 to 6 mils on flat areas. More thickness is allowed in fillet areas if there is no evidence of mud cracking, and if the coating is tight. The dry film thickness is measured from the peaks of the blast profile to the surface of the paint.

For contact surfaces of high strength bolted connections, the dry film thickness shall be 1.5 to 3 mils. Both sides of steel plates that have holes for high strength fasteners are considered contact surfaces because they come into contact with other steel plates, nuts, washers or fastener heads.

Apply 1.5 mils dry film thickness prime coat to top flanges of structural steel members that will have welded stud shear connectors applied in the field. Do not apply the prime coat to surfaces within 6 inches of field

welded connections. Coat unpainted surfaces near field welded connections with a rust preventive coating approved by the Engineer. The temporary coating must be easily removed with mineral spirits prior to field welding.

After the non-machined surfaces of structural steel are prime coated, remove the masking from the machined surfaces and apply a prequalified coating for use on machined surfaces approximately 3 mils thick.

If the dry film thickness of the prime coat is 2 to 3 mils, and less than 24 hours old, either blast clean the deficient area to bare metal and repaint, or apply additional primer. If additional inorganic zinc primer is applied, thin the primer 1:1 with a solvent recommended by the manufacturer of the paint.

If the dry film thickness of the prime coat is 2 to 3 mils thick and more than 24 hours old, or if the dry film thickness is less than 2 mils, blast clean the deficient area to bare metal and repaint. Remove excessive film thickness or dry spray.

Give the inorganic zinc prime coat a thorough single spray of clean water between 2 and 48 hours after application of the inorganic zinc prime coat, when recommended by the manufacturer.

Before the structural steel is shipped to the project site, blast clean to bare metal and repaint defective or damaged areas. Overlap the new prime coat onto the existing prime coat a minimum of 1 inch.

Shop painted structural items, except matchmarked girders and beams, that will receive a field coat of paint must have an identification mark painted on their surface, or they may be tagged with a weatherproof tag.

c. Field Painting New Structural Steel (Non-Weathering).

(1) Prime Coat. Apply a prime coat to the field connections, field welds, nuts, bolts and washers. Re-coat all damaged or defective areas of the shop-applied prime coat. Apply the prime coat in the field complying with the general requirements painting structural steel, with these additions and exceptions:

Overlap the shop coat by applying the field-applied prime coat a minimum of 1 inch beyond any surface preparation.

If the surface prepared for painting or re-coating is 1 square yard or less, apply organic zinc primer. Use organic zinc primer on bolts, nuts, washers and edges of bolted splice plates.

If the surface prepared for painting or re-coating is greater than 1 square yard, blast clean the entire flange or web of the area to be painted or re-coated, and apply inorganic zinc primer. Between 24 and 48 hours after the inorganic zinc primer is applied in the field, apply a coat of organic zinc primer (by brush or spray according to **subsection 714.3b.**) where the new inorganic zinc prime coat meets or overlaps the shop applied inorganic zinc prime coat.

If welded stud shear connectors are applied in the field, blast clean the top of the top flange to SSPC-SP6, Commercial Blast Cleaning. After the welded stud shear connectors are applied, blast clean the top flange and welded stud shear connectors to meet SSPC-SP6, Commercial Blast Cleaning. Thoroughly blast clean the welds. Apply organic zinc primer to the top flange and welded stud shear connectors. Prime the welded stud shear connectors (including the underside of the stud head). Given the complexity, areas of thin primer and some shadows are permissible on the top 1 inch.

(2) Finish coat. Protect the primed structural steel from contamination during transport, storage and erection. Do not walk on the primed structural steel. If the primed structural steel is soiled, use water or light blast cleaning to remove the contamination before applying the finish coat of paint.

The application of the finish coat in the field shall comply with the general requirements for painting structural steel, with these additions and exceptions:

Unless otherwise noted in the Contract Documents, either apply an acrylic or a polyurethane finish coat after the primed structural steel is erected. Apply 1 coat with a dry film thickness of 3 to 6 mils on flat areas. A thickness in excess of 6 mils is allowed in fillet areas if there is no evidence of mud cracking, and if the coating is tight. If bubbles form, allow them to collapse and apply approximately 1 mil of the finish coat to the area where the bubbling occurred.

d. Shop Painting New Weathering Steel. Apply the shop painting of new weathering steel complying with the general requirements for painting structural steel and the shop painting of non-weathering structural steel, with these additions and exceptions:

Blast clean all surfaces of the weathering steel, including all contact surfaces of bolted connections, to meet SSPC-SP6, Commercial Blast Cleaning.

For weathering steel surfaces that require painting, blast clean to meet SSPC-SP10, Near-White Blast Cleaning.

Surfaces that require paint include:

714 - PAINTING STRUCTURAL STEEL

- girder ends that are embedded in the abutment - the entire embedded portion of the girder, including diaphragms, plus an additional distance of 2 inches;
- the top (and sides, if in contact with concrete) of the top flanges, including shear studs and the underside of the stud head. Given the complexity, areas of thin primer and some shadows are permissible on the top 1 inch of shear studs. Note: for welded stud shear connectors applied in the field, the top of the top flange does not require a shop prime coat;
- all surfaces of top flange top splice plates;
- all surfaces of fill plates less than $\frac{1}{4}$ inch thick. Note: Fill plates need not be weathering steel. Paint fill plates of non-weathering steel, regardless of thickness;
- all structural steel surfaces (not included above) within a distance of 2 times the depth of the girder (2D) on either side of an expansion joint. (Note: A nearby stiffener is a convenient location to stop painting.); and
- the exterior girders according to **FIGURE 714-1**, if drainage is allowed over the side of the deck on a plate girder bridge, and the entire length of the exterior girder is to be painted. Note: If drainage is allowed over the side of the deck on a rolled beam bridge, painting of the exterior beam, except top flange, is not required.

e. Field Painting New Weathering Steel. Apply a finish coat to all primed structural steel surfaces still exposed after the placement of superstructure concrete. The surface preparation of the top surface of the top flange (field applied welded stud shear connectors), and the application of the prime coat (including the top of the top flange after welded shear stud connectors have been applied in the field) and the finish coat in the field shall comply with the general requirements for painting structural steel and the field painting of new, non-weathering structural steel, with these additions and exceptions:

Unless noted otherwise in the Contract Documents, use a waterborne acrylic, brown finish coat color equivalent to Federal Standard No. 595a, Color No. 30045 (Carboline No. 2248).

If drainage is allowed over the side of the deck on a plate girder bridge, and the entire length of the exterior girder is to be painted, apply a finish coat to the exterior girders according to **FIGURE 714-1**.

Unless shown otherwise in the Contract Documents, blast clean the entire exterior facia of the unpainted exterior girders after erection to meet SSPC-SP6, Commercial Blast Cleaning.

**FIGURE 714-1
WEATHERING STEEL**

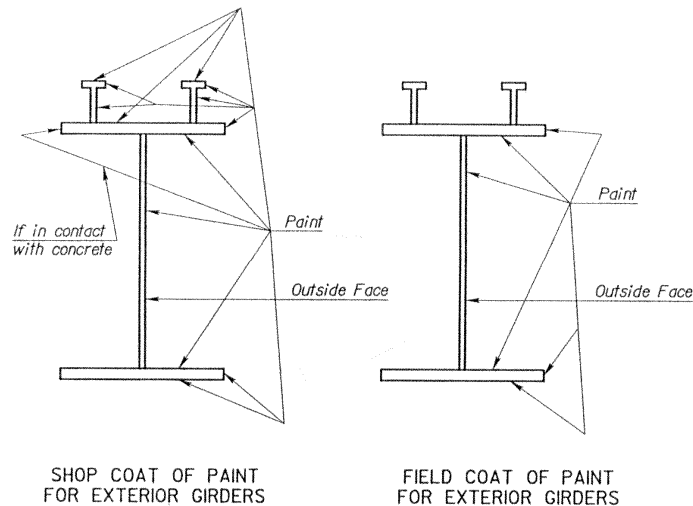

f. Painting Galvanized Steel. Follow ASTM D 6386 to prepare galvanized surfaces that are to be painted, then apply a primer tiecoat prior to application of the topcoat. Use a tiecoat that is compatible with the topcoat and approved by the Engineer. Follow the manufacturer's recommendations for application, including dry film thickness and cure time of the primer tiecoat.

g. Repainting Steel Bridges - Change Paint System. Repaint the steel bridges. Comply with the general requirements for painting structural steel, with these additions and exceptions:

Remove the existing paint system and repaint the bridge with a paint system of organic zinc or inorganic zinc prime coat and acrylic or polyurethane finish coat.

Clean and prepare the steel surfaces, including iron or steel casings and metal railings previously painted that are accessible for field painting. Do not paint tops of expansion guard plates, bars or angles across the roadway at joints between adjacent spans on which vehicular traffic comes in direct contact, and pipes or ducts owned by utility companies.

If lower chords, braces of truss spans or other members are separated by tie plates or fills, clean the spaces between backs of angles or channels (equal to the thickness of the tie plates or fills) of all rust and loose paint. Tight paint found between splice plates, beneath rivet heads and in other such narrow openings may be left intact. Take special care to remove the rust often found along the edges of the top flanges of I-beams at their line of contact with a concrete deck.

Apply the type of prime coat specified in the Contract Documents with 3 to 6 mils dry film thickness of the prime coat on flat areas. More thickness will be allowed in fillet areas if there is no evidence of mud cracking, and if the coating is tight.

After the prime coat is dry, give the inorganic zinc prime coat a thorough spray of clean water a minimum of 24 hours before the finish coat is applied. Organic zinc paint does not require a water spray.

Spray painting may be waived in those places where it is not possible to blast clean. Clean these areas by hand as well as possible, and apply a heavy coat of organic zinc primer with a brush or dauber.

Apply 1 finish coat with 3 to 6 mils dry film thickness on flat areas. A thickness in excess of 6 mils is allowed in fillet areas if there is no evidence of mud cracking, and if the coating is tight. If bubbles form, allow them to collapse and apply an approximate 1 mil of the finish coat to the area where the bubbling occurred.

h. Repainting Steel Bridges - Painting In Kind (Bridges with either organic zinc or inorganic zinc prime coat and acrylic or polyurethane finish coat paint systems). Repaint the steel bridges. Comply with the general requirements for painting structural steel, with these additions and exceptions:

Prepare the metal surfaces and repaint the bridge with the same paint system as existing.

Clean and prepare the steel surfaces, including iron or steel casings and metal railings previously painted that are accessible for field painting. Do not paint tops of expansion guard plates, bars or angles across the roadway at joints between adjacent spans on which vehicular traffic comes in direct contact, and pipes or ducts owned by utility companies.

If lower chords, braces of truss spans or other members are separated by tie plates or fills, clean the spaces between backs of angles or channels (equal to the thickness of the tie plates or fills) of all rust and loose paint. Tight paint found between splice plates, beneath rivet heads and in other such narrow openings may be left intact. Take special care to remove the rust often found along the edges of the top flanges of I-beams at their line of contact with a concrete deck.

Blast clean the steel surfaces to remove any defective coating. Hand clean widely spaced damaged spots (3/16 inch or less in diameter) on an otherwise tight existing coating. Remove oil and grease using a non-flammable solvent approved by the Engineer.

Clean areas according to SSPC-SP6, Commercial Blast Cleaning to produce a height of profile of 1 to 3 mils.

Apply 1 coat of organic zinc (minimum dry film thickness of 3 mils) to bare metal. Cover the bare metal and overlap the existing finish coat by 1 inch.

Spray painting may be waived in those places where it is not possible to blast clean. Clean these areas by hand as well as possible, and apply a heavy coat of organic zinc primer with a brush or dauber.

Use the type of finish coat specified in the Contract Documents. Apply 1 finish coat with 3 to 6 mils dry film thickness on flat areas. A thickness in excess of 6 mils is allowed in fillet areas if there is no evidence of mud cracking, and if the coating is tight. If bubbles form, allow them to collapse and apply an approximate 1 mil of the finish coat to the area where the bubbling occurred.

714.4 ENVIRONMENTAL PROTECTION (Existing Lead-based Paint Systems)

Provide environmental protection on a structure whether partially or completely removing an existing paint system that is defined as hazardous per federal Resource Conservation and Recovery Act (RCRA) Disposal

Regulations (40 CFR 261). The removal of existing lead-based paint may result in creation of waste subject to the above hazardous waste regulations.

a. Structure Classification. The bridge classification will be included in the Contract Documents, prior to letting.

For the purpose of this specification, bridges are classified as:

(1) Class A: A bridge in which any part is within 300 feet of:

- a residence, a school, a public use area, a commercial/industrial property, agricultural buildings;
- or a protected natural area property.

(2) Class B: Any bridge that is not Class A.

b. Health and Environmental Sampling.

(1) The Environmental Services Section (ESS) of the Bureau of Design will conduct a bridge Site Review and Field Survey (SRFS) to document the details of the project and the environmental concerns in the vicinity.

(2) Soil samples will be collected by the ESS prior to and at the conclusion of paint removal operations. While conducting the SRFS, soil samples will be collected within KDOT right-of-way from a minimum of 1 test site 10 to 100 feet away from the structure in each of 4 directions. The specific location of each site will be documented. Each test site shall consist of a 1 square foot area. A composite sample will be obtained by collecting soil $\frac{3}{4}$ inch in diameter and $\frac{1}{2}$ inch in depth at the center of the square and at each of the 4 corners.

At the conclusion of the project, soil samples will be collected by the ESS in the same manner at a 1 square foot area within a radius of 5 feet of the original sample location. The pre-job and post-job samples will be analyzed for total lead at a Kansas Department of Health and Environment (KDHE) certified laboratory.

(3) The air sampling equipment shall be provided by the Contractor and will remain the property of the Contractor. Collect air samples, unless stated otherwise in the Contract Documents, on all Class A bridges. Collect the samples following the procedures specified in the Code of Federal Regulations (CFR), 40 CFR 58, Appendix G and the quality assurance procedures as specified in 40 CFR 58, Appendix B and 40 CFR 58.20. Employ high volume air samplers to assess the effects of blasting operations on ambient air quality outside the containment structure. Collect air samples each day paint is blasted from the structure. Place the air samplers on KDOT right-of-way in the upwind and downwind position to the prevailing wind at locations expected to experience maximum impact. Locations for air sampling will be approved by the Engineer. Remove and replace the sample filters each day. Store the used filters in air-tight bags, properly identified with date, sample location and KDOT project number.

Submit the air sample filters to a KDHE certified laboratory a minimum of once every 5 working days, where they will be analyzed for total lead. Lead concentrations in ambient air must be in compliance with 40 CFR 50, which allows a maximum of 0.05 mil/cubic yard (See Guide 6, Section 5.5.4). The laboratory analyses must be accelerated in order to have analytical results to the Engineer within 5 working days of the original transmittal to the laboratory. Identify the analytical results by the date of collection, type and location of sample, and KDOT project number.

If ambient air concentrations exceed regulatory limits, halt blasting operations until containment design controls have been implemented to reduce emissions to a satisfactory level.

(4) Collect surface water samples on all bridges located over any perennial stream, river or body of water. Sediment samples may also be required, at the discretion of the Engineer, where stream flow is extremely low, where containment has obviously failed or when paint removal operations exceed 30 calendar days. At the direction of the Engineer, a minimum of 1 sample shall be collected upgradient of the structure and 1 in the down gradient position of the structure during blasting operations. The samples will be representative of the project's potential impact to the water body and will be collected in the presence of the Engineer. If visible waste or paint chips are observed on the surface of the waterway, halt blasting operations until the containment has been modified to eliminate debris contact with the water surface. This determination will be made by the Engineer. Identify water samples by date, type and location of sample, and KDOT project number. Submit the water samples to a KDHE certified Laboratory for the analysis of total lead within 1 week from the time of collection. Submit the analytical results to the Engineer upon receipt from the laboratory. Identify the analytical results by date of collection, type of sample, Chain of Custody forms, and KDOT project number.

(5) Failure to submit analytical data for air and water samples on a timely basis as described above may result in work on the project being suspended by the Engineer until submittals are in compliance. Temporary suspension of work on the project due to non-compliance by the Contractor will not alter or waive the charging of working days for the project.

(6) Submit all documentation relative to air and water sample collection and analyses to the ESS within 30 days of completion of the paint removal process. If documentation is not submitted, the Engineer may stop work on the project until such documentation has been received by the Engineer and ESS.

c. Notifications and Record Keeping. The ESS will submit a SRFS report to the Bureau of Waste Management (BWM), KDHE, Forbes Field, Topeka, Kansas 66620-0001 a maximum of 60 days before beginning work on the bridges. At the same time, a copy will also be provided to the Bridge Management Section and the appropriate KDOT District Office. The District Office will provide a copy of the Site Review and Field Survey report to the Contractor.

At the conclusion of the blasting operations, the ESS will submit a report to the BWM, which includes the results of all air, soil, and surface water samples obtained during the project. A copy of this report will also be provided to the appropriate District Office. The Contractor may receive a copy of this report upon request to the Engineer or ESS.

d. Lead Base Paint Removal. The Contractor engaged in lead base paint removal operations must carry a pollution liability (access liability) policy with a minimum coverage of \$1,000,000. Maintain this policy in force until the Secretary releases the Contractor from all obligations under the contract. The insurance contract must cover claims for such length of time as said claims are permitted by law. Provide a copy of this insurance certificate to the Engineer prior to beginning lead base paint removal operations.

Use best industry practices to protect the environment, persons and adjacent property from contamination due to blasting of the existing structure. When "Power Wash" is shown as a bid item, clean the existing steel before initiating the blasting operations. Use a power washer with pressure in the range of 700 to 1000 pounds per square inch to clean the structure, at a maximum rate of 4 gallons per minute, using potable water. Comply with all applicable regulations contained in K.A.R. 28-16-28 (b) through (f) for protection of water quality, K.A.R. 28-29-1 through 28-29-27 for disposal of solid waste and K.A.R. 28-31-1 through 28-31-14 for disposal of hazardous waste. In addition, comply with all applicable Occupational Safety and Health Administration standards including those found in 29 CFR 1910.1025 covering the occupational exposure to lead and 29 CFR 1926.62 outlining the requirements for the removal of lead-based paint from bridge repair and rehabilitation activities.

Contain paint chips, corrosion residues and spent abrasives, referred to as waste materials, resulting from blasting and other cleaning operations. The containment requirements are covered in **subsection 714.4e**. Use special containment methods or removal procedures over power lines, communication lines, railways or roadways not closed to traffic. Obtain the permits and permission from the line owner on the containment methods and removal procedures. The proposed containment method or removal procedures must be sealed by a licensed Professional Engineer, and submitted to the Engineer before commencing paint removal operations.

Clearing of the work area for containment purposes is the responsibility of the Contractor. Clearing may not extend beyond right-of-way. Burning on the right-of-way is prohibited. The area to be cleared and the clearing method must be approved by the Engineer before starting the clearing operation. Provide locations, approved by the Engineer, and dispose of all the debris at said locations.

e. Removal and Containment Requirements.

(1) Class A Bridges. On all Class A bridges, provide a KDHE certified Lead Abatement Supervisor for oversight of all paint removal, storage and disposal operation. These operations shall adhere to work practices established in K.A.R. 28-72-18(g) and K.A.R. 28-72-18d(a). The Lead Abatement Supervisor must have available at the job-site a telephone number for the nearest Local Emergency Planning Commission (LEPC), or if none can be found within a 50 mile radius, the nearest Haz-Mat Response Contractor.

Dry abrasive blasting or any other approved method which meets the paint specification may be used to remove the lead paint from the bridge. Use the containment methods shown below to maximize pollution control.

(a) Power Tools: Use containment unless the power tools are vacuum equipped and all parts of the vacuum equipment are in a condition that prevents emissions of waste material. This determination will be made by the Engineer.

(b) Dry Abrasive Blasting: Use 100% air impenetrable walls with rigid or flexible framing, fully sealed joints, airlock or resealable entryways, and negative air achieved by forced or natural air flow (verified by instrument or visual monitoring) and exhaust air filtration (See SSPC – Guide 6, Paragraph 4.2.2.1).

Design the containment to withstand the effects of negative air pressure equal to the combined volume of all blast nozzles inside the enclosure plus 4 air changes of the enclosure per hour. The

method of attaching and the effects of dead load caused by the installation of the enclosure to the bridge shall be sealed by a licensed Professional Engineer. Provide a copy of such plans to the Engineer for approval before commencing paint removal operations.

Recyclable or non-recyclable abrasive may be used. Use recyclable abrasives with a classifier system rated to remove a minimum of 98% of the non-abrasive material, and free of oil substances.

Do not allow the waste material to contact the ground or water surface. Plywood or other impermeable material may be used, subject to approval by the Engineer. When the roadway beneath the structure is closed, the hard surfaces such as asphalt and concrete roadway, sidewalks and sloped paving may be left uncovered if they have an unbroken surface, and can be cleaned by sweeping or vacuuming as described in **subsection 714.4f.(1)**. If the roadway surface is used for waste material collection, cover the storm drains.

(c) Visible emissions are permitted at given frequencies or durations provided they do not extend beyond KDOT right-of-way. Permissible visible emissions for Class A bridges are defined as random emissions of a cumulative duration of a maximum of 1% of the work day, equivalent to 5 minutes in an 8 hour period (See SSPC-Guide 6, Paragraph 5.5.1.1). The Engineer will determine if visible emissions limitations are being exceeded. Temporary suspension of work on the project may be ordered by the Engineer if visible emissions exceed limitations. The ordering of a temporary suspension for exceeding emissions limitations will not alter or waive the charging of working days for the project.

(2) Class B Bridges. Dry abrasive blasting or any other approved method which meets the paint specification may be used to remove the lead paint from the bridge. Use the containment methods shown below to maximize pollution control.

(a) Power Tools: The Contractor is subject to the limitations for Class A Bridges as described in **subsection 714.4e.(1)(a)**.

(b) Dry Abrasive Blasting: Use 100% impermeable tarpaulins or heavy plastic (6 mil minimum thickness) to prevent disposition of waste material on the soil or water surface. Plywood or other impermeable material may be used subject to approval by the Engineer. Overlap the ground cover a minimum of 1 ½ feet and weight them as needed to prevent separation. Cover all bare soil and vegetated areas inside the curtains required by items below, and extend a minimum of 20 feet beyond in all directions except at abutments. When the roadway beneath the structure is closed, the hard surfaces such as asphalt and concrete roadway, sidewalks and sloped paving may be left uncovered if they have an unbroken surface, and can be cleaned by sweeping or vacuuming as described in **subsection 714.4f.(1)**. If the roadway surface is used for waste material collection, cover the storm drains.

- Curtains: Use curtains in the form of rigid or flexible walls, rated by the manufacturer at a minimum of 85% impermeable to contain lead paint particles and dust generated from the blasting operation. Use curtains with adequate strength to withstand wind velocity. Plywood or other impermeable material may be used, subject to approval by the Engineer. Attach and overlap the edges of the walls a minimum of 3 feet, unless the edges are completely joined.
- Girders and Deck Trusses: Rigid or flexible walls may be suspended from the bridge deck to the ground so that the work area is contained on all 4 sides. Attach and overlap the edges of the walls a minimum of 3 feet, unless the edges are completely joined. Extend the wall up between the girders to seal this space. Extend the walls to the ground, and anchor or weight at the bottom. An exhaust fan with an adequate filter system may be required to protect the personnel within the confinement.
- Thru and Overhead Trusses: If the roadway is open to traffic, suspend rigid or flexible 85% impermeable walls both inside and outside of the truss from a height greater than the point to be removed, with the inside edge resting on the deck and secured by weights, and the bottom outside edges fastened within the lower walls attached to the bridge deck in the manner required for girders.

If the roadway is closed to traffic, suspend rigid or flexible 85% impermeable walls outside from a height greater than the point of paint removal with the lower edges fastened within the lower walls attached to the bridge deck in a manner required for girders; or suspend a rigid barrier outside the truss with the bottom edge resting on or directly above the roadway and inclined at an angle of 45° with the truss to deposit waste material on the closed roadway.

The height must be at a minimum, equal to the height of the truss, and with the space between the end of the barrier and truss closed with impermeable material. Suspend rigid or flexible walls across the bridge deck between the opposite trusses at both ends of the area to be blasted. On truss bridges provide a document sealed by a licensed Professional Engineer noting the amount of work area allowed for containment.

- Over a Body of Water: If a project site is located within 0.5 mile upstream of any public water supply intake, the ESS will notify the applicable public entity of project activity within 30 days of commencing paint removal operations.

Rigid or flexible 100% impermeable material may be suspended horizontally beneath the bridge deck to contain the waste material; or suspend scaffolding that supports a platform beneath the bridge deck lined with impermeable material to contain the waste material; or for bridge decks within 50 feet of the water surface, anchor a barge beneath the bridge and use impermeable material to direct waste material to the barge; or for bridge decks that are within 50 feet of a frozen water surface, collect and remove waste material from the ice surface with ground cover as required in **subsection 714.4e.(2)(b)**. Extend the distance of ground cover in a downwind direction to a distance greater than the highest point of the paint removal. Extend the material used to contain the girders and trusses from outside the paint surfaces to inside of the containment walls, the platform, inside the barge or inside the containers on the barge.

Over a narrow body of water, the following methods may be used as an alternate to the methods shown above. Cover a platform above the water surface with 100% impermeable material that overlaps the ground covers; or suspend an impermeable material across the underside of the bridge deck at a point more than halfway across the water body to direct paint particles to the farther bank. Anchor the containment at the bank so that it overlaps the ground covers, and seal the space above the containment in between the beams. Repeat the procedure in the opposite direction. The rigid or flexible walls used to contain the material from the girders or the trusses shall extend from outside the painted surfaces to the platform or inside the horizontal containment material.

In addition, employ floating booms down gradient of the structure if any waste material is detected floating on the water surface. Use a skimmer or wet vacuum to capture any waste material or paint chips.

(3) Wind Speed Limitations: Do not conduct paint removal operations whenever wind speed or other weather conditions render the containment ineffective or unsafe. If excessive visible emissions of particulate matter occur in the air or in visible deposits on the ground or water surface due to adverse weather conditions, either halt operations until the weather and/or wind speed is at a workable level, or increase design controls to adequately accommodate weather related conditions. The Engineer shall make this determination.

(4) Alternative Method of Removal: Alternate methods of removal may be proposed. Submit the alternate proposal to the State Bridge Engineer a minimum of 30 days in advance of use. Include site-specific design and engineering controls appropriate for the proposed alternative method. The alternate method must be approved by KDHE and KDOT before initiation.

f. Waste Material Cleanup, Storage and Treatment.

(1) Cleanup of Waste Material: Clean up all visible deposits of waste materials at the end of each work day and store them in secured containers above normal high water elevation, within KDOT right-of-way as describe in further detail in item **subsection 714.4f.(3)**. Recover this material by manual means or by vacuum with filtration. Do not use an air pressure or a water stream which redistributes, but does not remove the waste material. Collect material from the roadway and from floating booms as needed, and at a minimum at the end of each day.

(2) Storage of Waste Material: Consider generated waste material to be a hazardous waste until representative analytical results have been received by the ESS and the Engineer, indicating that the waste is non-hazardous, pursuant to 40 CFR 261 and the KDHE.

(a) While classified as a hazardous waste, store the waste material according to the requirements of K.A.R. 28-31(g) or (h). In addition to K.A.R. 28-31(g) or (h), in the plan for storage of waste material, include the following:

- Store the waste material in secured drums, bulk hoppers, bins or rolloffs. Clearly mark the containers with the words “Hazardous Waste”, the KDOT project number and the date upon which the period of accumulation began for each container;

714 - PAINTING STRUCTURAL STEEL

- Store the waste containers on an impermeable surface that accommodates sweeping or vacuuming;
 - Do not accumulate hazardous waste for more than 90 days. If an extension of time is needed, seek approval from the ESS; and
 - The Engineer is designated the “Emergency Response Coordinator” and is responsible for coordinating all emergency response measures outlined in K.A.R. 28-31-40(h).
- (b) In order to classify generated waste as non-hazardous for on site storage, obtain a minimum of 2 composite samples at the direction of and in the presence of the Engineer. The sample must be representative of the total volume of waste generated through that point in time, as determined by the Engineer. Submit the samples to a KDHE certified laboratory and test for lead according to the TCLP Method SW 1311/7420, pursuant to 40 CFR 261, Appendix II. Maintain proper Chain of Custody forms at all times. The Contractor shall bear the costs of all sampling and analyses.
- If the sample analyses indicate the waste to be non-hazardous, less than 5 mg/L, the analytical results serve as representative documentation for the remainder of the waste generated on that project site, provided changes are not made to the method of paint removal, the type of blast media or any other portion of the paint removal operation that would render the samples non-representative of the total volume of waste. These criteria will be evaluated at the discretion of the Engineer;
 - KDOT reserves the right to conduct random sampling at any time to assure that paint removal operations have not been altered in such a way as to compromise the representative nature of the original samples. KDOT will bear the cost of any random sampling ordered unless said sample analyses determines the waste to be hazardous, whereupon the Contractor will be responsible for the cost of sample analyses. If the waste is found to be hazardous through random sampling, the entire volume of waste generated shall be considered hazardous;
 - Store non-hazardous waste material in secured containers and place on an impermeable surface which accommodates sweeping or vacuuming; and
 - Mark each storage container with the KDOT project number and date upon which the period of accumulation began.

(3) Sampling and Analysis of Waste Material.

- Collect representative composite samples of the waste material at the direction of and in the presence of the Engineer. Sampling and testing procedures and contaminant limits are described in **subsection 714.4f.(2)(b)**;
- A minimum of 2 samples are required and may be the same 2 samples described as initial waste characterization in **subsection 714.4f.(2)(b)**. Additional samples shall be required in order to total a minimum of 2 samples per ton of waste generated. The Contractor shall bear the cost of all sampling and analyses;
- All samples collected must fall below the 5 mg/L TCLP regulatory requirement in order to dispose of any of the waste as non-hazardous, pursuant to K.A.R. 28-29-109.

(4) Disposal of Waste Material.

- (a) If all samples indicate a lead content below 5 mg/L, dispose of the entire volume of waste generated as follows:
- Provide documentation confirming the disposal of said waste at a KDHE permitted landfill to the Engineer within 15 business days of the disposal. If documentation is not submitted, the Engineer may stop work on the project until such documentation has been received by the Engineer and ESS; or
 - Recycle according to **subsection 714.4f.(4)(b)**;
 - DO NOT DISPOSE OF THIS MATERIAL AS A HAZARDOUS WASTE.
- (b) If any sample indicates a lead content at or above 5 mg/L, recycle the entire volume of waste generated as follows.
- Recycle waste material through an EPA approved lead recycling facility, pursuant to 40 CFR 261.1. For the purposes of transport, the waste may be designated as “recyclable”;

714 - PAINTING STRUCTURAL STEEL

- Prior to commencement of the project, provide the Engineer documentation confirming the pre-acceptance of the recyclable materials by the recycling facility;
- Provide the Engineer documentation identifying the volume of waste transported from the project site; and
- Within 15 business days of acceptance by the EPA approved recycling facility, provide the Engineer and ESS documentation confirming the acceptance of the waste and the volume as delineated above. If documentation is not submitted, the Engineer may stop work on the project until such documentation has been received by the Engineer and ESS.
- DO NOT DISPOSE OF THIS MATERIAL AS A HAZARDOUS WASTE.

g. Inspection Staff. KDOT will not inspect the surfaces from which the paint has been removed by abrasive blasting until the air quality inside the enclosure is below the Permissible Exposure Limit (PEL), and preferably below the Action Level (AL). This inspection will occur before any paint is applied to the surface.

Provide the necessary facility for removal of and disposal of protective clothing. Provide a location and facility for the Inspector to wash exposed body areas.

h. General Site Cleanup. The Contractor is responsible for general cleanup of the job site after paint removal and painting operations have been completed. This includes but is not limited to cleanup of all debris associated with paint removal and painting operations, trash generated by Contractor personnel, as well as any excess blast media and/or paint chips. Cleanup will also include re-establishment of any vegetative cover disturbed by abatement activities, including damage caused by storing equipment and traffic at the site. Clean up lead-bearing waste according to **subsection 714.4f**. This determination will be made by the Engineer.

714.5 MEASUREMENT AND PAYMENT

The Engineer will not measure painting of new structural steel for payment. Payment for painting new structural steel is included in the payment for the structural steel.

The Engineer will measure bridge painting, environmental protection and power washing, of existing steel by the lump sum.

Payment for "Bridge Painting", "Environmental Protection" and "Power Wash" at the contract unit prices is full compensation for the specified work.