

**731 - AREA PREPARED FOR PATCHING (EXISTING CONCRETE BRIDGE DECKS)**

**SECTION 731**

**AREA PREPARED FOR PATCHING  
(EXISTING CONCRETE BRIDGE DECKS)**

**731.1 DESCRIPTION**

Perform all work necessary to remove all asphalt material and unsound concrete from the existing bridge or the designated area to the depth specified in the Contract Documents, or as designated by the Engineer.

**BID ITEMS**

Area Prepared for Patching  
 Area Prepared for Patching (Full Depth)  
 Area Prepared for Patching (Poured with Overlay)  
 Area Prepared for Patching (Set Price)  
 Area Prepared for Patching (Full Depth) (Set Price)

**UNITS**

Square Yard  
 Square Yard  
 Square Yard  
 Square Yard  
 Square Yard

**731.2 MATERIALS**

Provide materials that comply with the applicable requirements.

Concrete ..... **SECTIONS 401 & 402**  
 Aggregates for Concrete Not On Grade ..... **SECTION 1102**  
 Concrete Curing/Precure Materials ..... **DIVISION 1400**  
 Reinforcing Steel ..... **DIVISION 1600**  
 Epoxy Resin Base Bonding Systems ..... **DIVISION 1700**  
 Rapid Set Concrete Patching Materials\* ..... **SECTION 1716**

**\*When specified in the Contract Documents.**

On bridge decks that do not receive a concrete overlay, use coarse aggregate complying with **SECTION 1102**, except grading must adhere to **TABLE 731-1**.

<b>TABLE 731-1: AGGREGATE GRADATION</b>	
<b>Sieve Size</b>	<b>Percentage Retained</b>
¾ "	0
½ "	0-10
⅜ "	15-50
#8	90-100

**731.3 CONSTRUCTION REQUIREMENTS**

**a. General (All Decks).** Remove asphalt material and unsound concrete as shown in the Contract Documents and as designated by the Engineer, to the depth required to reach sound concrete and rust free reinforcing steel. Dispose of removed material on sites approved by the Engineer.

Unless specifically noted in the Contract Documents, the Contractor may choose to remove unsound concrete by other means capable of removing the required concrete, without injury to the sound concrete and reinforcing steel.

Unless specifically noted in the Contract Documents, the Contractor may **not** choose to remove unsound concrete by hydrodemolition. When hydrodemolition is allowed, remove the required concrete, without injury to the sound concrete and reinforcing steel. When hydrodemolition is allowed and used as the method of removal, the Engineer will determine the areas of unsound concrete after hydrodemolition.

Do not use jack hammers or chipping hammers heavier than the nominal 15-pound class on any partial depth concrete removal. Jack hammers up to the nominal 30-pound class may be used in areas of full depth patching to within 6 inches of the edges of the designated areas. Do not use chipping hammers heavier than a nominal 15-pound class to remove the 6-inch edge. Operate jack hammers and chipping hammers at an angle to prevent damage to the sound concrete.

## 731 - AREA PREPARED FOR PATCHING (EXISTING CONCRETE BRIDGE DECKS)

(1) Reinforcing. Remove all scale and heavy rust from steel bars. When concrete is removed by jack hammers, wet sandblasting is prohibited. If reinforcing is left exposed, and signs of rust appear, the Engineer may require that the cleaning be repeated. Do not cut, stretch or damage any exposed reinforcing steel. Do not break the bond between the reinforcing steel and concrete where bars are partially exposed yet remain anchored in sound concrete, near the ends or where more than half the bar is beneath the concrete removal line. See **FIGURE 731-1**.

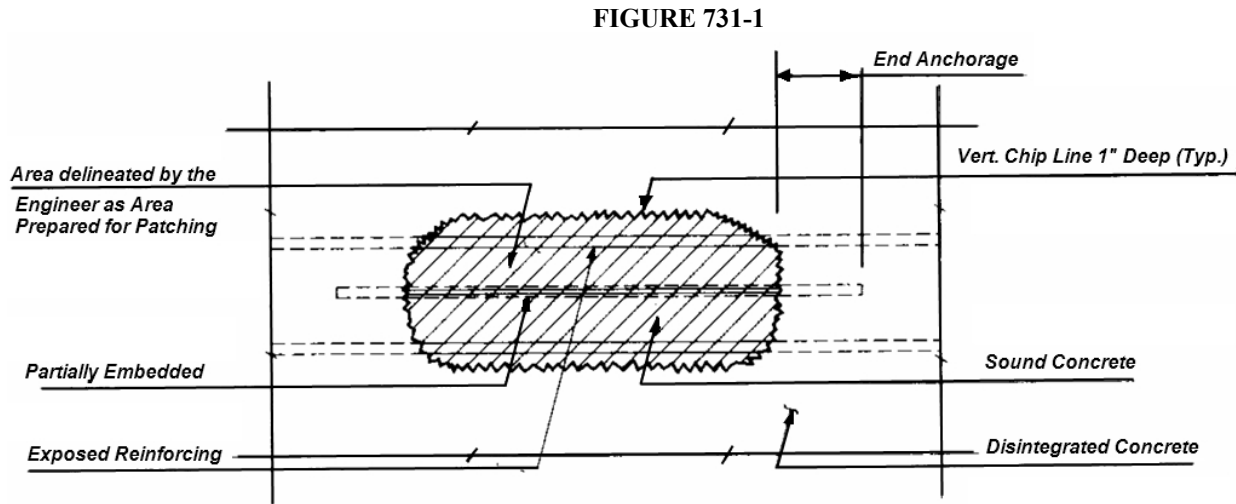

### (2) Bonding of Reinforcing Steel.

(a) Top Layer of Transverse Reinforcing Bars. Where the bond between existing concrete and the top layer of transverse reinforcing steel has been destroyed (**FIGURE 731-2**), remove the concrete adjacent to the bar to a depth that shall permit concrete to bond to the entire periphery of the bar with a minimum clearance of  $\frac{3}{4}$  inch. A bar may be considered bonded by the Engineer even if less than  $\frac{1}{2}$  the bar depth is embedded in concrete.

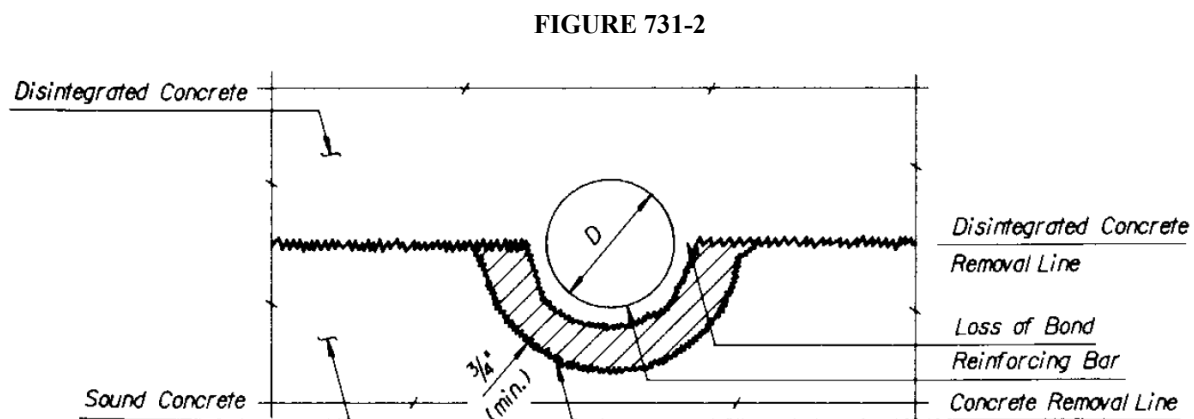

(b) All Reinforcing Bars Other Than the Top Layer of Transverse Bars. Where more than  $\frac{1}{2}$  the diameter of the steel is exposed (**FIGURE 731-3**), or where the bond between existing concrete and reinforcing steel has been destroyed (**FIGURE 731-2**), remove the concrete adjacent to the bars to a depth that shall permit concrete to bond to the entire periphery of the bar with a minimum clearance of  $\frac{3}{4}$  inch.

## 731 - AREA PREPARED FOR PATCHING (EXISTING CONCRETE BRIDGE DECKS)

FIGURE 731-3

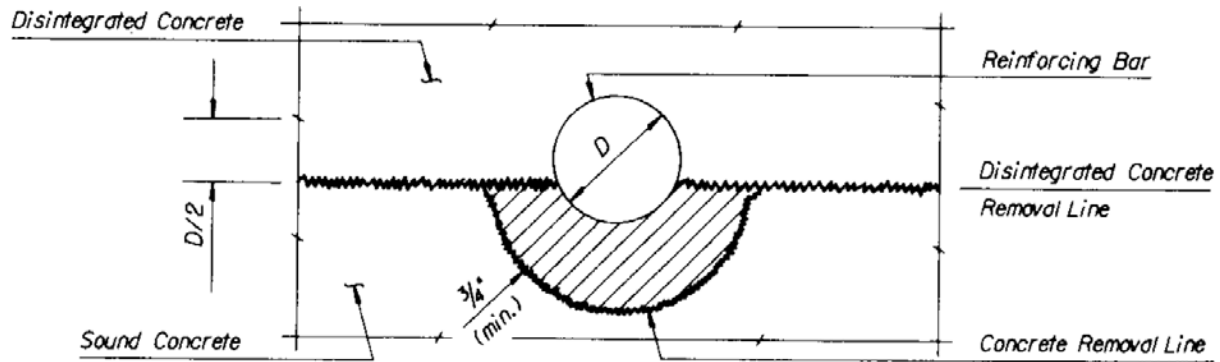

(3) Concrete Surface Preparation. Wet the surface with water, but prevent free standing water. No grout is required.

(4) Epoxy Resin Base Bonding Agent. Coat all abutting vertical edges in full depth patches with an epoxy resin bonding agent. Apply the adhesive material according to the manufacturer's recommendations, just prior to the placement of patching concrete. Provide good bond of the patch material at the edges of the patch area by applying additional vibration or hand tamping. If epoxy resin dries, reapply another coating.

(5) Concrete Placement. Place concrete according to **SECTION 710**.

(6) Segmental Construction. When large scale patches in the deck result in the debonding of the reinforcing steel, patch in segments to the size and spacing shown in the Contract Documents or as designated by the Engineer. After the initial segments have cured, if required, patch the areas between segments. Heavy equipment, such as volumetric mixing equipment, is prohibited on full depth patches for a minimum of 24 hours after the curing period has ended.

(7) Concreting in Hot Weather. Adhere to **subsection 710.3** when concreting in hot weather. A monomolecular film may be used to prevent rapid evaporation of water rising to the surface of the concrete. Do not use the film to work up grout as an aid to finishing operations. Use precure to prevent rapid evaporation between the initial strike off and brooming prior to covering with the curing media at ambient air temperatures above 70°F, or when combinations of temperature, low humidity and wind create conditions which, in the judgment of the Engineer, require hot weather procedure. Apply 1 or more light applications of monomolecular film as required by weather and finishing conditions. Complete curing as noted in **subsection 731.3c.(4)**.

(8) Concreting in Cold Weather. Except by specific written authorization, concreting operations are prohibited when a descending air temperature falls below 45°F. Do not start or resume concreting operations until the ascending ambient air temperature reaches 40°F.

**b. Bridge Decks That Are To Receive An Overlay.** Use aggregate specified for Grade 4.0(AE) concrete. Use the course aggregate specified for wearing surface. Patching concrete slump must be 2 ½ to 3 ½ inches.

Cure a minimum of 24 hours prior to placing the new overlay.

On partial depth areas where there is no loss of bond with the reinforcing steel, fill patched with Grade 4.0(AE) concrete or with the type of concrete specified for the overlay. Place partial depth patches less than 1 inch thick along with the overlay. The remaining patches may be placed just before or as the overlay is placed, unless shown otherwise in the Contract Documents. Fill all prepoured patches to a level approximately ¼ inch below the top of the old existing deck. Cure the prepoured patches a minimum of 24 hours.

Adhere to **TABLE 731-2** for the minimum length of cure time after the placement of all full depth concrete patches and/or removal of adjacent concrete on segmental patching and prior to placing overlay.

## 731 - AREA PREPARED FOR PATCHING (EXISTING CONCRETE BRIDGE DECKS)

TABLE 731-2: BRIDGE PATCHING CURING	
Minimum length of Cure Time*	Ambient Air Temperature Range (°F)
48 hours	Above 60
72 hours	40 to 60
120 hours	32 to 40

\*In special circumstances, longer cure times may be required by the Engineer.

Use wet burlap or polyethylene sheet for curing or cure according to **subsection 710.3e.** and **TABLE 710-1** for subdecks.

### c. Bridge Decks That Do Not Receive An Overlay.

(1) Removal of Old Concrete. Remove unsound concrete to the limits designated in the Contract Documents or by the Engineer. Prior to removal, saw the perimeter of the patch, but do not saw into the reinforcing steel. Chip out the connecting edges below the sawed portion to nearly true lines. Do not damage sound concrete and dispose of the removed materials on sites approved by the Engineer. Perform final cleanup with a high pressure water jet with a minimum pressure of 3,500 psi or by sandblasting methods.

(2) Composition and Consistency of Concrete. Use Grade 4.0(AE) concrete with a slump between 2 ½ to 3 ½ inches at the point of placement.

(3) Placing, Consolidating and Finishing Concrete. Carefully place concrete to prevent segregation. Vibrate using a spud vibrator. Do not touch the old concrete underneath. Tamp the concrete in place using hand tamps with a maximum of 36 square inches of face. Strike off and finish the patch with wooden floats, followed by a light brooming for final finish.

(4) Curing. Apply the curing material after the finishing operation when marring the surface shall not occur. Cure the concrete surface using wet burlap and polyethylene sheets according to **subsection 710.3e.** and **TABLE 710-1** for bridge deck wearing surfaces. Keep the curing material in place for a minimum of 72 hours, unless designated otherwise by the Engineer. Keep burlap continuously wet during the curing period.

### d. Bridge Decks That Receive a Multi-Layer, Single-Layer or Slurry Polymer Concrete Overlay.

(1) Polymer concrete materials may be used for patching of the concrete bridge deck.

For shallow patches, 3 inches maximum depth, polymer concrete overlay resin and FA-C aggregate, **TABLES 1102-3** and **1102-4**, may be used.

For deep patches, greater than 3 inches polymer concrete overlay resin with an approved MA-1 or MA-2 aggregate, **TABLE 1102-6**, may be used.

The slurry polymer concrete system may be used for shallow and deep patching with the manufacturer/supplier's recommendation.

Mix and cure all patching according to manufacturer/supplier's recommendations.

(2) A Rapid Set Concrete Patching Material, compatible with the overlay may be used for patching the concrete bridge deck.

(3) Strike off patches to a level approximately ¼ inch below the top of the original concrete deck.

## 731.4 MEASUREMENT AND PAYMENT

The Engineer will measure the area prepared for patching by the square yard after the designated thickness of surface has been removed. The measured pay quantity will be those areas sounded by the Engineer and marked as unsound or delaminated concrete.

The Engineer will measure full depth patching prior to placement of patching concrete.

The Engineer will measure areas of partial depth patching poured with the overlay before the overlay is placed. Pay quantity for partial depth patching will be the marked areas of unsound or delaminated concrete minus the sum of the partial depth patching poured with the overlay and the full depth patching.

Payment for "Area Prepared For Patching" and "Area Prepared For Patching (Full Depth)" at the contract unit prices and "Area Prepared For Patching (Set Price)" and "Area Prepared For Patching (Full Depth) (Set Price)" at the contract set prices are full compensation for the specified work when shown in the contract.

### **731 - AREA PREPARED FOR PATCHING (EXISTING CONCRETE BRIDGE DECKS)**

When the contract items include both "Area Prepared for Patching" and "Area Prepared for Patching (Full Depth)", the price bid for "Area Prepared for Patching (Full Depth)" shall be a minimum of  $1\frac{1}{4}$  times the price bid for "Area Prepared for Patching". Failure to comply with this requirement is cause for rejection of the bid.

"Area Prepared for Patching (Poured with Overlay)" will be paid at 70% of the contract unit price for "Area Prepared for Patching" and is full compensation for the specified work. Payments made for of "Area Prepared for Patching (Poured with Overlay)" will be shown as an added item to the contract. Concrete for the partial depth patching poured with the overlay will be paid for as provided in the overlay specification.

When no contract item is shown for "Area Prepared For Patching (Full Depth)" and upon approval of the Engineer, areas prepared for patching that are full depth requiring forming on the underside shall be paid for at a rate of  $2\frac{1}{4}$  times the contract unit price per square yard of "Area Prepared For Patching".

Concrete used to fill patched areas shall be subsidiary to other items of the contract.